

ILLUSTRATED PARTS LIST

MARCH 1961

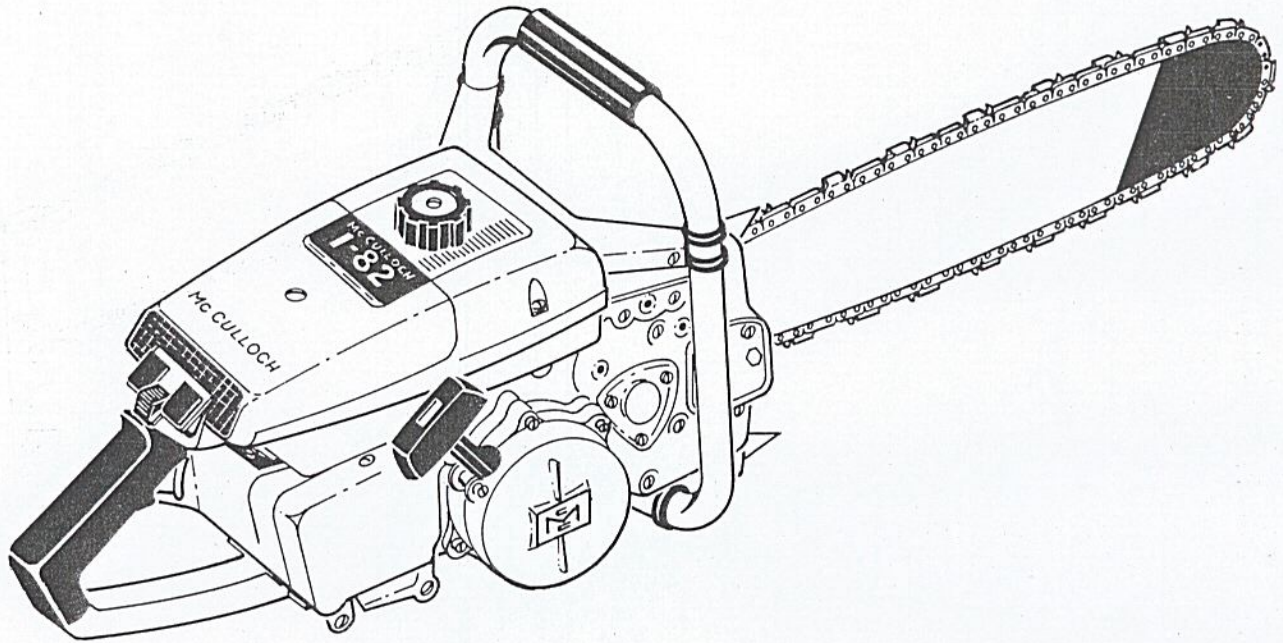

The following pages contain an illustrated parts list for the Model 1-82 Chain Saw. Due to small differences between saws, it is important that the Serial Number of your saw be included whenever spare parts are ordered. This will assure receiving the proper parts from your dealer.

	Page
Figure 1. Engine Exploded View - General	2
Figure 2. Fuel System Components	4
Figure 3. Starter and Clutch Assembly	6
Figure 4. Transmission Assembly	8
Figure 5. Powerhead Assembly	10
Figure 6. Carburetor Assembly	12
Figure 7. Lockplate Adjusting Assembly, Bar and Chain	14
Figure 8. Plunge Bow Saw Assembly	16
Figure 9. Handle and Control Assembly	18



McCULLOCH CORPORATION
6101 West Century Boulevard, Los Angeles 45, California

#57810

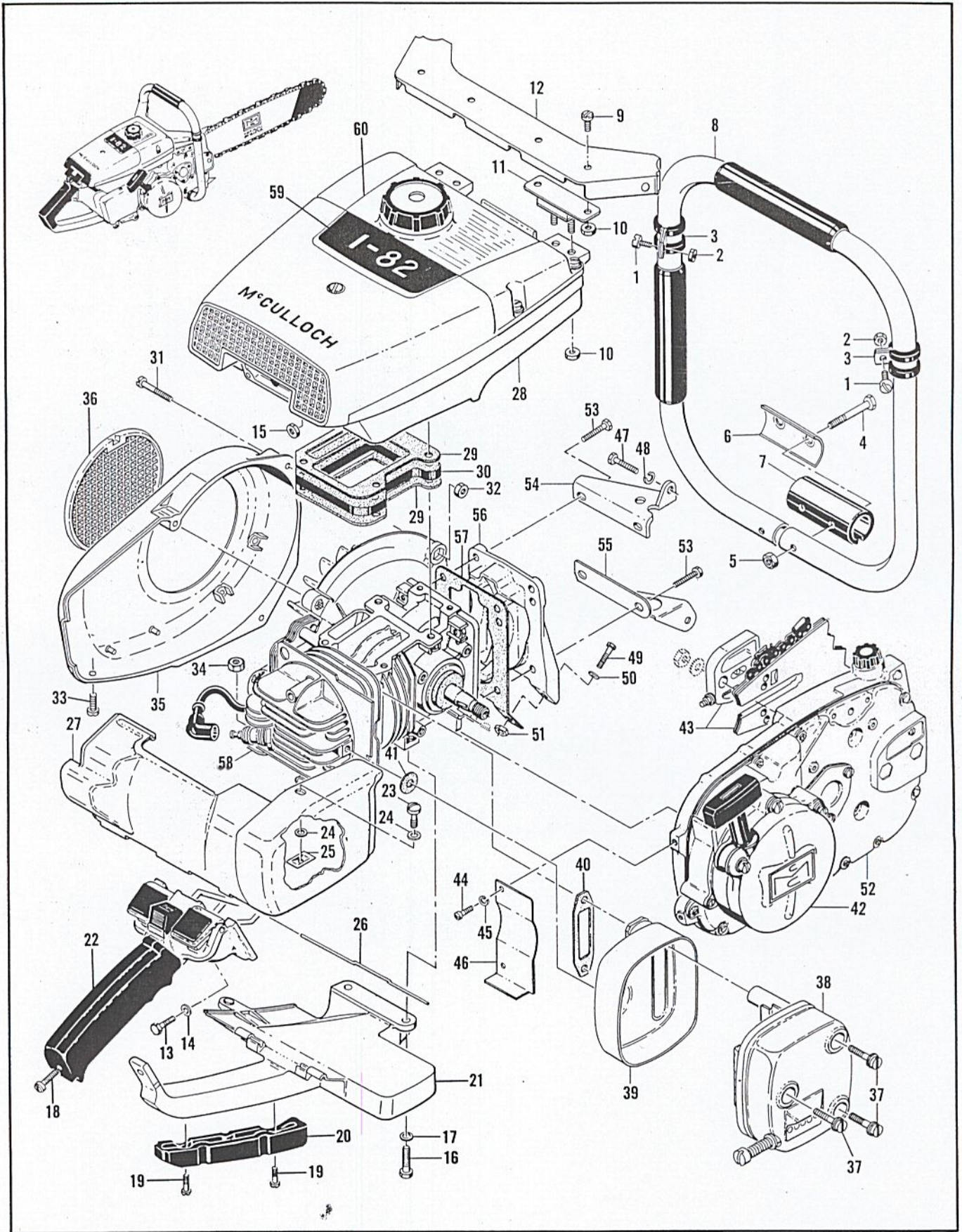

Figure 1. Engine Exploded View - General

FIGURE 1 ENGINE EXPLODED VIEW—GENERAL

Index No.	Part Number	Nomenclature	Units Per Assy
1	102763	Screw - Pan hd 10-24 x 3/4 in. lg	2
2	100239	Nut - Hex 10-24	2
3	103923	Clamp	2
4	102125	Screw - Hex hd 1/4-20 x 1-3/4 in. lg	2
5	101143	Nut - Hex 1/4-20	2
6	51660	Clamp - Frame	1
7	51661	Insulator	1
8	55678	Frame and Grip Assy	1
9	104393	Screw - Pan hd 10-24 x 3/8 in. lg	4
10	101191	Nut - Hex 10-24	8
11	55606A	Mount - Shock	2
12	55638	Brace - Frame	1
13	102761	Screw - Hex hd 10-24 x 7/8 in. lg	2
14	102189	Washer	2
15	102067	Nut - Hex 10-24	2
16	102121	Screw - Hex hd 1/4-20 x 7/8 in. lg	2
17	100005	Washer	2
18	102500	Screw - Pan hd 10-24 x 1/2 in. lg	1
19	104477	Screw - Bind hd 10-24 x 1/2 in. lg	2
20	55941	Insert - Handle	1
21	57872	Brace - Handle	1
22		Handle and Control Assy (See figure 9)	1
23	51351	Screw - Special	1
24	100005	Washer - Plain 1/4 in.	2
25	103741	Speednut	1
26	55885	Pin - Shroud hinge	1
27	55419A	Shroud Assy - Cylinder and muffler	1
28		Fuel System Components (See figure 2)	1
29	58330	Gasket - Bottom fuel tank	2
30	57771	Insulator	1
31	104503	Screw - Fil hd 10-24 x 1-1/4 in. lg	3
32	101191	Nut - Hex 10-24	2
33	104397	Screw - Pan hd 10-24 x 7/8 in. lg	1
34	102067	Nut - Hex 10-24	1
35	57733	Housing - Fan	1
36	55615	Guard - Flywheel	1
	55838A	Muffler Assy	1
37	55998	. Screw - 10-24 x 5/8 in. lg (SEMS)	3
38	55820A	. Top Assy - Muffler	1
39	55828	. Bottom Assy - Muffler	1
40	36093	Gasket - Muffler	1
41	55213	Washer - Insulating	1
42		Starter and Clutch Assy (See figure 3)	1
43		Lockplate Adjusting Assy, Bar and Chain (See figure 7)	1
44	102762	Screw - Hex hd 10-24 x 1/2 in. lg	2
45	101194	Washer - Lock	2
46	51664A	Shield - Gearcase	1
47	100882	Screw - Hex hd 1/4-20 x 3/4 in. lg	1
48	100153	Washer - Lock	1
49	100882	Screw - Hex hd 1/4-20 x 3/4 in. lg	1
50	100005	Washer - Plain 1/4 in.	1
51	101143	Nut - Hex 1/4-20	1
52		Transmission Assy (See figure 4)	1
53	101982	Screw - Hex hd 1/4-20 x 1 in. lg	4
54	51795A	Brace - Gearcase top	1
55	55537	Brace - Gearcase bottom	1
56	51601C	Cover - Crankcase bottom	1
57	51738B	Gasket - Bottom	1
58		Power Head Assy (See figure 5)	1
59	57804	Nameplate	1
60	55702A	Instruction Plate	1

FIGURE 2 FUEL SYSTEM COMPONENTS

Index No.	Part Number	Nomenclature	Units Per Assy
	55626	Cover Assy - Air cleaner	1
1	55622	. Screw - Special air cleaner	1
2	103741	. Speednut	1
3		. Cover - Air cleaner (Order Assy #55626)	1
4	55498	Screen - Air cleaner	1
5	55659	Grill - Air cleaner cover	1
6	104396	Screw - Pan hd 10-24 x 3/4 in. lg	1
7	55634	Anchor Assy - Air cleaner	1
8	55857A	Hose - Fuel line	1
9	55958	Arm Assembly - Governor	1
10	55966	Spring	1
11	55964	Lever Assembly	1
12	104154	. Screw - Set 8-32 x 1/4 in. lg	1
13		Tillotson Carburetor Assy (See figure 6)	1
14	104396	Screw - Pan hd 10-24 x 3/4 in. lg	14
15	55627	Gasket - Fuel tank	1
16	57485	Plate - Fuel cap	1
17	55934	Cap - Fuel assy	1
18	101348	“O” Ring - Fuel cap	1
19	55588	Top - Fuel tank	1
20	55436	Spring - Wick retaining	1
21	55404	Clamp - Fuel wick	1
22	55405	Wick - Fuel tank	1
23	57772	Screw - Fuel tank mounting	4
24	103744	Washer - Sealing	2
25	55636	Washer - Insulating	4
26	55865	Washer - Sealing buna	2
27	100002	Washer - Plain No. 10	2
28	103740	Screw - Hex hd 8-32 x 7/8 in. lg	2
29	51480	Lockplate	1
30	57658	Clamp - Reed	1
31	57654	Deflector - Fuel	1
32	51809A	Valve - Reed	1
33	57656	Plate - Reed	1
34	58328	Gasket	2
35	102941	Screw - Hex 10-24 x 1/2 in. lg	3
36	102189	Washer	3
37	55636	Washer - Insulating	2
38	55907	Shield Assy - Fuel tank	1
39	55647	Retainer - Pushrod	1
40	51394	Felt - Pushrod	1
	55805B	Bottom Assy - Fuel tank	1
41	104504	. Rivet	1
42	101871	. Washer - Plain	1
43	51396A	. Cover Assy - Adjustment hole	1
44	104310	. Pin - Cotter	1
45	51561	. Grommet	2
46	103708	. Bushing	1
47		. Fuel Tank - Bottom (Order Fuel Tank Bottom Assy #55805B)	1

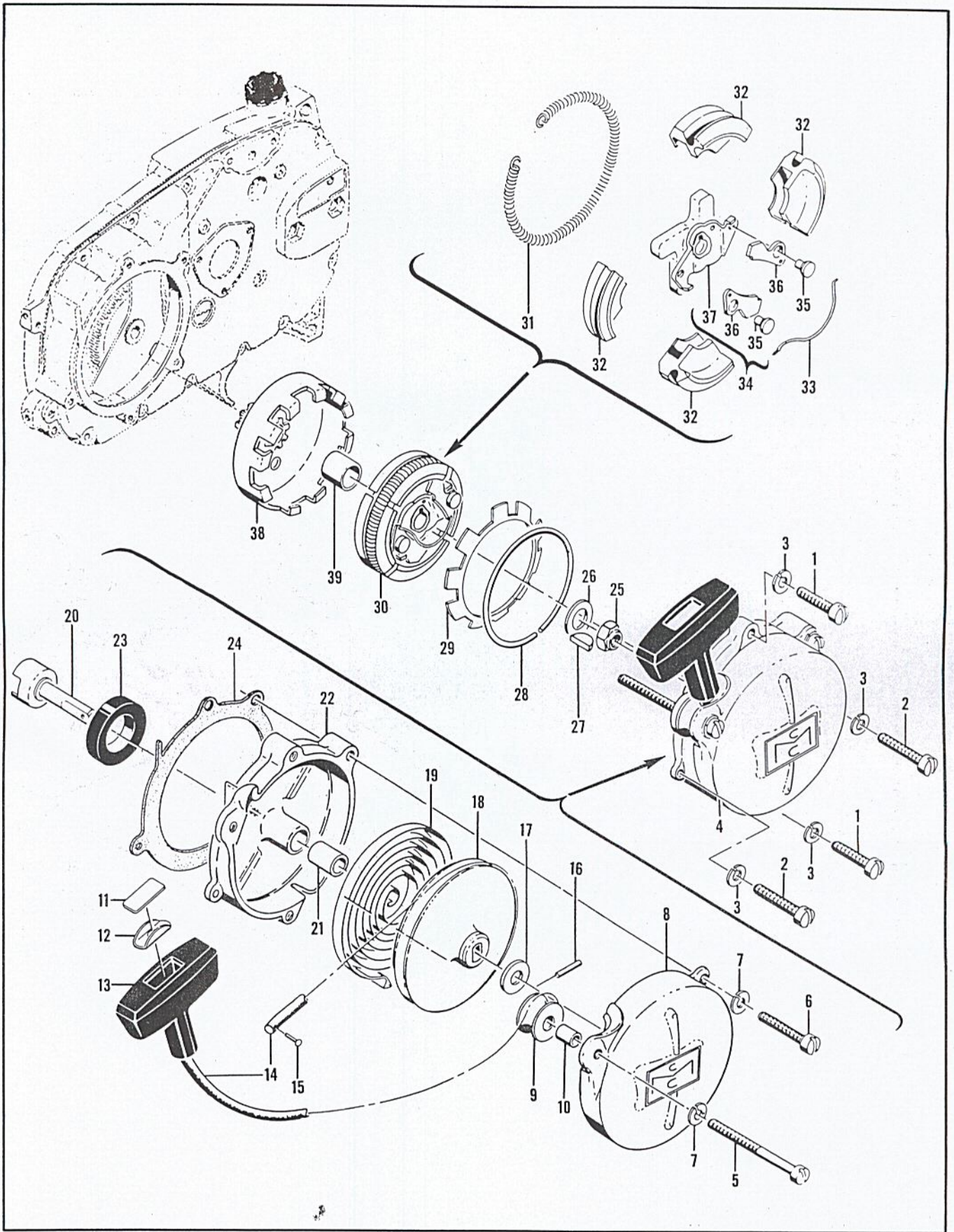

Figure 3. Starter and Clutch Assembly

FIGURE 3 STARTER AND CLUTCH ASSEMBLY

Index No.	Part Number	Nomenclature	Units Per Assy
1	102212	Screw - Fil hd 10-24 x 1-3/4 in. lg	2
2	102135	Screw - Fil hd 10-24 x 2 in. lg	2
3	100240	Washer - Lock	4
4	55129C	Starter Assy	1
5	103840	. Screw - Fil hd 10-24 x 3-1/2 in. lg	1
6	102135	. Screw - Fil hd 10-24 x 2 in. lg	1
7	100240	. Washer - Lock	2
8	55024B	. Cover - Starter	1
9	51138	. Pulley - Starter rope	1
10	103536	. Bearing - Starter pulley	1
11	57232	. Plate - Starter handle	1
12	57231	. Cup - Starter handle	1
13	57230	. Handle - Starter	1
14	28716	. Rope - Starter	1
15	101136	. Rivet	1
16	103047	. Pin	1
17	104457	. Washer	1
18	55871	. Drum - Starter	1
19	51665	. Spring - Rewind	1
20	55110	. Shaft - Starter	1
	51649B	. Base Assy - Starter	1
21	55591	. . Bearing - Starter base	1
22		. . Base - Starter (Order Starter Base Assy #51649B)	1
23	104439	. Seal	1
24	55983	Gasket - Starter base	1
25	103746	Nut - Flexloc 3/8-24	1
26	104349	Washer - 3/8	1
27	103879	Key - Woodruff	1
28	*51646C	Ring - Disc retaining .0630 oversize	As Req
	51646D	Ring - Disc retaining .0710 oversize	As Req
	51646E	Ring - Disc retaining .0800 oversize	As Req
	51646F	Ring - Disc retaining .0900 oversize	As Req
	51646G	Ring - Disc retaining .1060 oversize	As Req
	51646H	Ring - Disc retaining .1180 oversize	As Req
29	51645A	Disc - Clutch friction	1
30	55716C	Clutch Assy	1
31	51644	. Spring - Shoe retaining	1
32	55523B	. Shoe - Clutch (Set of four)	1
33	28766	. Spring - Pawl	1
34	55717	. Rotor and Pawl Assy	1
35	28917	. . Pin	2
36	28765	. . Pawl	2
37		. . Rotor Assy (Order Rotor and Pawl Assy #55717)	1
38	51859	Clutch Drum Assy	1
39	51700	. Bearing	1

FIGURE 4 TRANSMISSION ASSEMBLY

Index No.	Part Number	Nomenclature	Units Per Assy
	55927A	Transmission Assy (3.0 - 1 Ratio)	1
1	51631A	. Bolt - Bar	2
2	103464	. Screw - 10-24 x 3/4 in. lg (SEMS)	11
3	103947	. Screw - 10-24 x 1 in. lg (SEMS)	3
4	101864	. Plug - Pipe 1/16 x 27	1
5	104218	. Plug - Pipe 3/8-18	1
6	55914	. Cover - Gearcase	1
7	55913	. Gasket - Cover	1
8	102500	. Screw - Pan hd 10-24 x 1/2 in. lg	6
9	101194	. Washer - Lock	6
10	55736	. Cover - Sprocket shaft	1

FIGURE 4 TRANSMISSION ASSEMBLY (CONT.)

Index No.	Part Number	Nomenclature	Units Per Assy
11	36138	. Retainer - Bearing	1
12	51621	. Gasket - Shaft cover	2
13	104298	. Seal - Oil	1
14	101039	. Bearing	2
15	55715	. Spacer - Gear	2
	55926	. Shaft Assy - Sprocket (3.0 - 1 Ratio)	1
16	55953	. . Key - Sprocket shaft	1
17	55925	. . Gear - Sprocket drive (3.0 - 1 Ratio)	1
18	104451	. . Ring - Snap	1
19	57489	. . Shaft - Sprocket	1
20	103280	. Screw - Hex hd 1/4-28 x 5/8 in. lg	1
21	100004	. Washer - 1/4 plain	1
22	103976	. Screw - Hex hd 1/4-28 x 7/16 in. lg	1
23	104351	. Screw	1
24	55539	. Lockplate - Idler yoke	1
25	100640	. Nut - Hex 1/4-28	2
26	55928A	. Idler Gear and Yoke Assy (3.0 - 1 Ratio)	1
27	51755	. Plug - Oiler valve	2
28	51944	. Spring	1
29	100549	. Ball - 3/16 in. dia.	1
30	57721	. Body - Oiler	1
31	19236	. Spring - Oiler	1
32	101056	. Ring - "O"	1
33	36126	. Piston - Oiler	1
		. Weight Assy - Oil pump	1
34	51506	. . Screen	1
35	51509	. . Weight	1
36	28007	. Hose - Flex	1
37	57234	. Plate - Oil cap	1
38	57129	. Cap - Filler	1
39	101148	. Ring - "O"	1
	55879A	. Gearcase Assy	1
40	18556A	. . Retainer - Nut	2
41	101143	. . Nut - Hex 1/4-20	2
42	51982	. . Valve Assy - Check	1
43	100993	. . Pin - Dowel	1
44	100010	. . Pin - Cotter	2
45		. . Gearcase	1
46		. . Gearcase (Order Gearcase Assy)	1
	*36020B	Sprocket - 6 tooth 1/2 in. pitch	1
	*36644A	Sprocket - 7 tooth 1/2 in. pitch (Alternate)	1
	**36790A	Sprocket - 6 tooth 9/16 in. pitch (Alternate)	1
	**36791A	Sprocket - 7 tooth 9/16 in. pitch (Alternate)	1
47	57719	Oiler rod (Item 3, figure 9)	1
48	55449A	Washer - Felt	1
49	102128	Screw - Hex hd 1/4-20 x 1-1/4 in. lg	3
50	36306	Lockplate	3
51	100005	Washer - Plain 1/4	3
52	104535	"O" Ring	1
53	100882	Screw - Hex hd 1/4-20 x 3/4 in. lg	2
54	51654	Spike	1
55	102415	Screw - Pan hd 10-24 x 3/8 in. lg	2
56	101194	Lockwasher	2
57	51634B	Guard - Chain	1
58	51632B	Protector - Gearcase	2
59	101179	Nut - Hex 7/16-20	1
60	100593	Washer - 7/16	1
61	51627	Plate - Chain guide	1
62	36019A	Shroud - Sprocket	1
63	55953	Key - Woodruff	1
64	55737	Spacer - Sprocket	1

*Use only with 1/2 inch pitch chain.

**Use only with 9/16 inch pitch chain.

Note: Optional 3.6 - 1 Ratio Gear Set Kit, P/N 55932, is available.

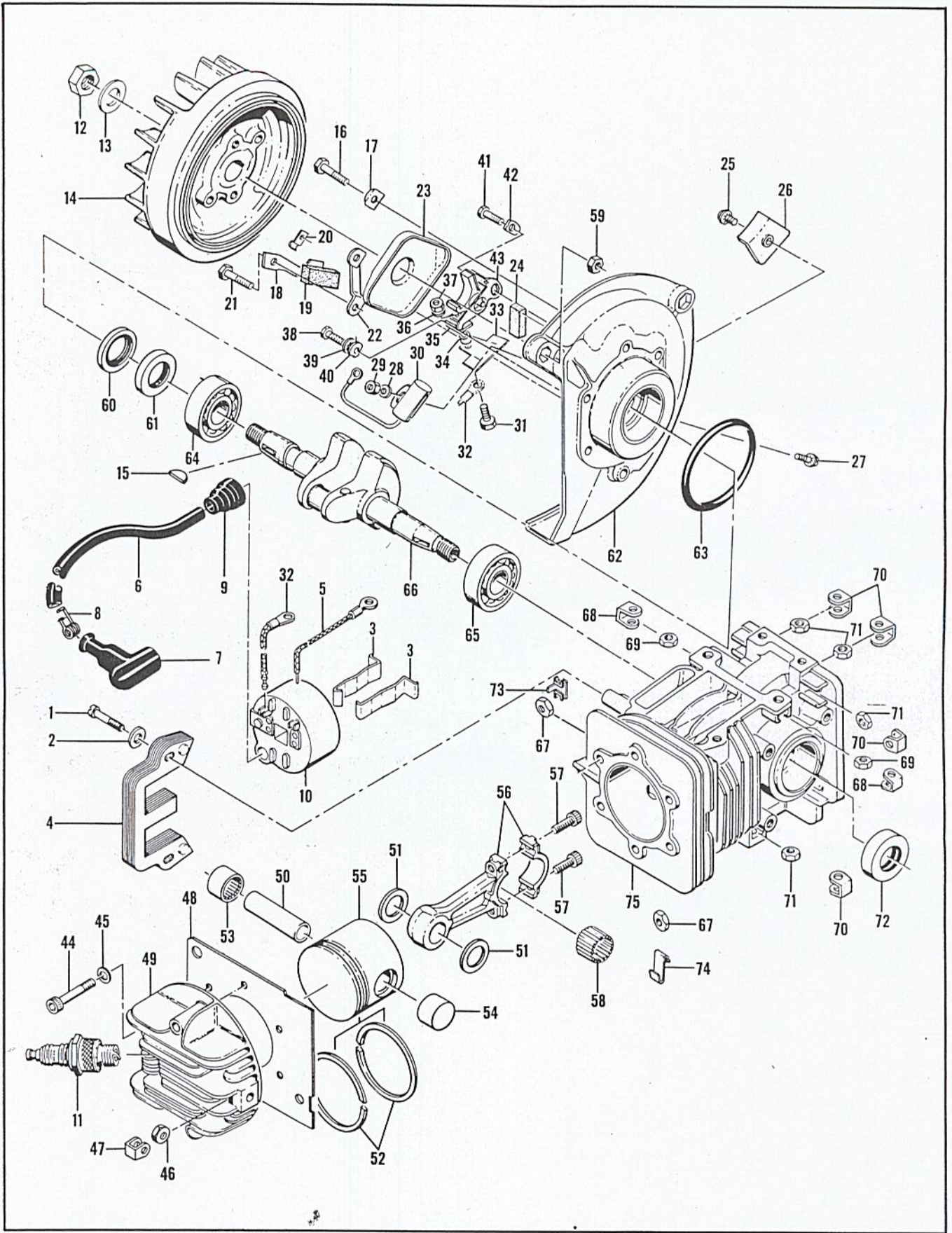

Figure 5. Powerhead Assembly

FIGURE 5 POWERHEAD ASSEMBLY

Index No.	Part Number	Nomenclature	Units Per Assy
1	101965	Screw - Fil hd 10-24 x 7/8 in. lg	2
2	100003	Washer	2
3	51253	Retainer - Coil	2
4	51251	Lamination Assy - Coil	1
	55949	Coil and Terminal Assy	1
5	101883	. Wire Assy - Ground	1
6	52547	. Wire Assy - Spark plug	1
7	55060	. . Boot - Spark plug	1
8	55061	. . Connector - Spark plug	1
9	55617	. Nipple - Spark plug	1
10		. Coil Assy (Order Coil and Terminal Assy 55949)	1
11		Plug - Spark 14 mm	1
12	101179	Nut - Hex 7/16	1
13	101270	Washer - Special	1
14	57825	Flywheel Assy	1
15	103879	Key - Woodruff	1
16	102763	Screw - Hex hd 10-24 x 3/4 in. lg	2
17	36388	Plate - Lock	1
18	57815	Strap - Seal	1
19	50664	Seal - Breaker box drain	1
20	104230	Speednut	2
21	102763	Screw - Hex hd 10-24 x 3/4 in. lg	4
22	55977	Clip - Breaker box cover	2
23	55766B	Cover - Breaker box	1
24	54184	Wiper - Felt	1
25	104570	Screw - 8-32 x 1/4 in. lg (SEMS)	1
26	57829	Clamp - Ignition wire	1
27	104555	Screw - Fil hd 8-32 x 1/2 in. lg (SEMS)	1
28	100080	Washer - Plain No. 8	1
29	100955	Nut - Hex 8-32	2
30	50074	Condenser	1
31	103748	Screw - Hex hd 8-32 x 1/2 in. lg	1
32	57766	Wire Assy - Primary	1
33	55782	Insulator	1
34	57769	Insulator - Ignition screw	1
35	57770	Insulator - Breaker spring	1
36	104553	Lockwasher - No. 8	1
37	104551	Nut - 8-32	1
38	100414	Screw - Fil hd 8-32 x 1/2 in. lg	1
39	100057	Lockwasher	1
40	55778A	Washer - Special	1
41	103061	Screw - 8-32 x .375 in. lg (SEMS)	1
42	57767	Lockplate	1
43	57765	Breaker Assy	1
44	101563	Screw - Socket hd 10-24 x 1-1/4 in. lg	6
45	24236	Washer	6
46	101326	Nut - Hex 10-24	1
47	28053	Retainer - Nut	1
48	55012B	Gasket	1
49	55355B	Head - Cylinder	1
50	57198	Pin - Piston	1
51	51209	Washer - Thrust	2
	48695	Piston Assy (Also see Oversize Assy - Page 19)	1
52	48691	. Ring Set - Piston	1
53	101206	. Bearing - Needle	1
54	104378	. Bearing - Needle (Closed end)	1
55		. Piston (Order Piston Assy #48695)	1
56	55009	Connecting Rod Assy	1
57	101356	. Screw - Socket hd 10-32 x 5/8 in. lg	2
58	102742	. Roller - Needle	24
	57827	Crankcase Cover Assy	1
59	101326	. Nut - Hex 10-24	1

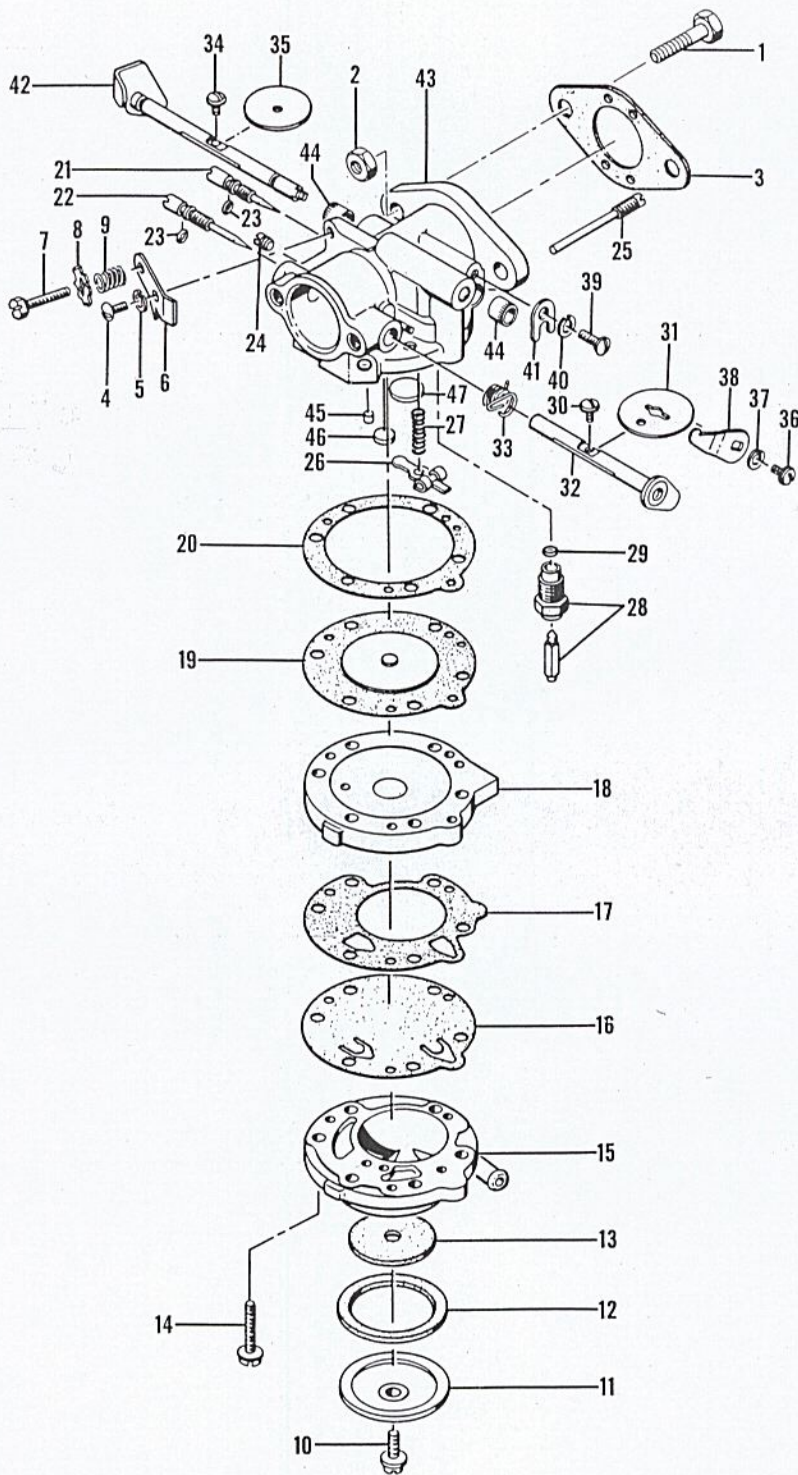

Figure 6. Carburetor Assembly

FIGURE 5 POWERHEAD ASSEMBLY (CONT.)

Index No.	Part Number	Nomenclature	Units Per Assy
60	57870	. Seal - Oil	1
61	57784	. Seal - Oil	1
62		. Cover - Crankcase (Order Assy #57827)	1
63	104523	"O" Ring	1
64	100824	Bearing - Ball	1
65	104490	Bearing - Ball	1
66	57756	Crankshaft	1
	57894	Cylinder Assy - Crankcase	1
67	101326	. Nut - Hex 10-24	6
68	28053	. Retainer - Nut	2
69	101326	. Nut - Hex 10-24	2
70	18556A	. Retainer - Nut	6
71	101143	. Nut - Hex 1/4-20	6
72	57732	. Seal - Oil	1
73	104255	. Retainer - Nut	2
74	57063	. Retainer - Nut	4
75		. Cylinder - Crankcase (Order Assy #57894)	1

FIGURE 6 TILLOTSON CARBURETOR ASSEMBLY

Index No.	Part Number	Nomenclature	Units Per Assy
1	100882	Screw - Hex hd 1/4-20 x 3/4 in. lg	2
2	103242	Nut - Hex 1/4-20	2
3	51161C	Gasket - Carburetor	1
	51984B	Carburetor Assy	1
4	100362	. Screw - Idle bracket retaining	1
5	100252	. Washer - Lock No. 8	1
6	51706	. Bracket - Idle screw	1
7	103845	. Screw - Hex hd 8-32 x 5/8 in. lg	1
8	51549	. Washer - Special	1
9	51705	. Spring - Idle speed regulating screw	1
10	50797	. Screw - Fuel strainer cover	1
11	50796	. Cover - Fuel strainer	1
12	50798	. Gasket - Fuel strainer cover	1
13	50795	. Element - Fuel filter	1
14	51597	Screw - Fil hd 6-32 x 3/4 in. lg	6
15	50670	. Body - Fuel pump	1
16	57574	. Diaphragm - Fuel pump	1
17	51594	. Gasket - Fuel pump	1
18	51592	. Cover - Main fuel diaphragm	1
19	51590	. Diaphragm - Main fuel	1
20	51591	. Gasket - Main fuel diaphragm	1
21	51702	. Needle - Adjustment, idle mixture	1
22	51712	. Needle - Adjustment, main mixture	1
23	51703	. "O" Ring	2
24	51589	. Screw - Drain plug	1
25	51710	. Pin - Inlet lever fulcrum	1
26	51709	. Lever - Inlet control	1
27	51711	. Spring - Inlet control lever	1
28	51707A	. Needle, Seat, and Gasket Assy	1
29	51708	. Gasket - Needle seat	1
30	51721	. Screw - Choke shutter (SEMS)	1
31	51587	. Shutter - Choke	1
32	51585	. Shaft Assy - Choke	1
33	55511	. Spring - Torsion (choke shutter return)	1
34	51721	. Screw - Throttle shutter (SEMS)	1
35	51720	. Shutter - Throttle	1
36	51719	. Screw - Throttle lever retaining	1
37	100261	. Washer - Lock No. 4	1

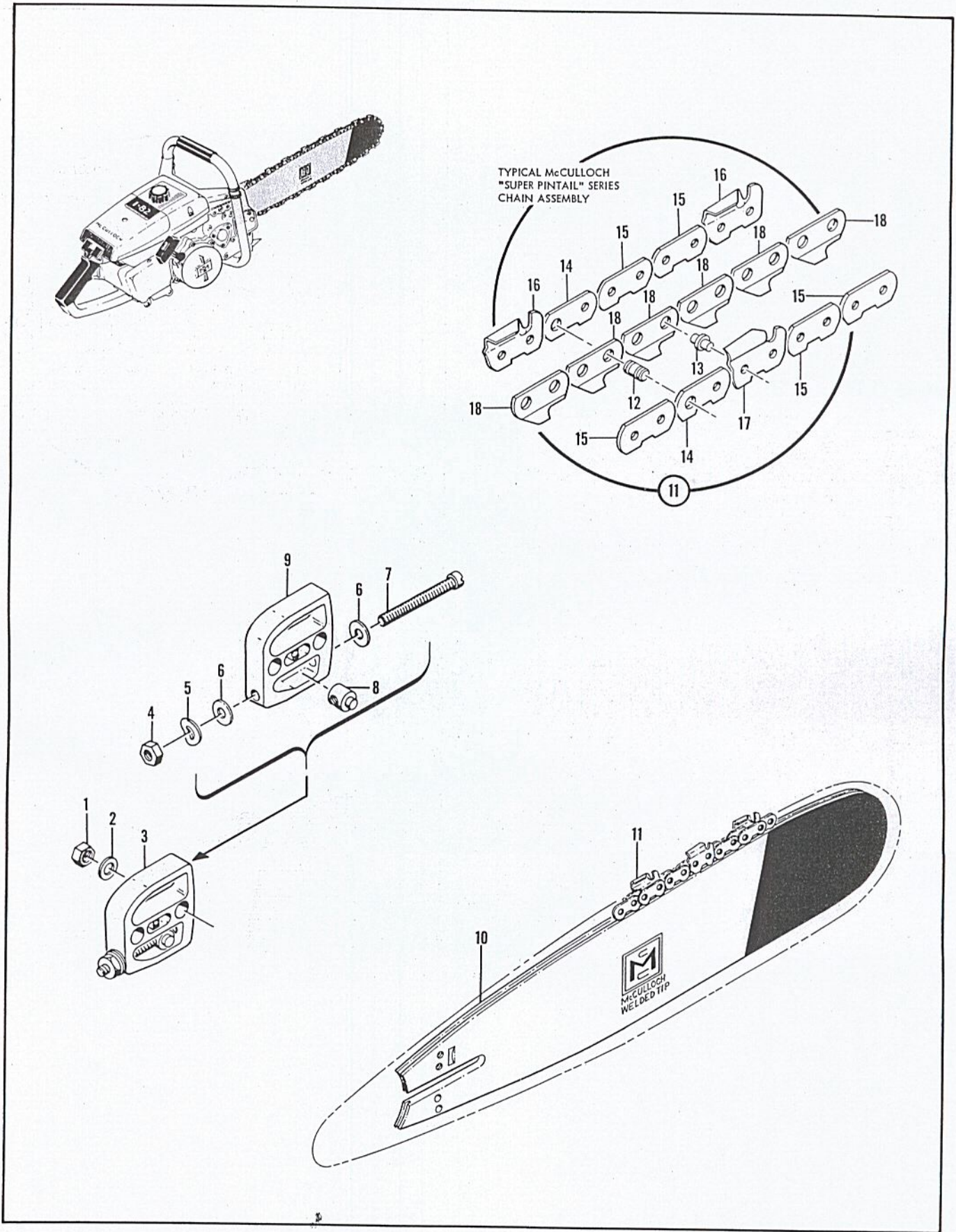

Figure 7. Lockplate Adjusting Assembly, Bar and Chain

FIGURE 6 TILLOTSON CARBURETOR ASSEMBLY (CONT.)

Index No.	Part Number	Nomenclature	Units Per Assy
38	57893	. Lever - Throttle shaft	1
39	51717	. Screw - Throttle shaft clip	1
40	100252	. Washer - Lock No. 8	1
41	51716	. Clip - Throttle shaft	1
42	55512	. Shaft Assy - Throttle	1
43	51588B	. Carburetor Body Assy (For service)	1
44	51715	. . Bushing - Throttle Shaft	2
45	51582	. . Plug - Body channel cup	1
46	51583	. . Plug - Body channel welch, 3/8 in.	1
47	51584	. . Plug - Body channel welch, 1/4 in.	1

FIGURE 7 LOCKPLATE ADJUSTING ASSEMBLY, BAR AND CHAIN

Index No.	Part Number	Nomenclature	Units Per Assy
1	103729	Nut - Hex 3/8-24	2
2	100393	Washer - 3/8 in.	2
3	52211D	Lockplate Adjusting Assy	1
4	100640	. Nut - Hex 1/4-28	1
5	102813	. Washer - Spring	1
6	102843	. Washer	2
7	103919	. Screw - Fil hd 1/4-28 x 2-1/2 in. lg	1
8	52207C	. Nut - Adjusting	1
9	52206B	. Lockplate	1
10	51403B	Bar - 12 in.	1
	51405A	Bar - 18 in. (alternate)	1
	51407A	Bar - 24 in. (alternate)	1
	51409A	Bar - 30 in. (alternate)	1
11		Typical McCulloch "Super Pintail" Series Chain Assy	1
12		. Master Pin	
13		. Shoulder Rivet	
14		. Master Link	
15		. Side Link	
16		. Cutter - L.H.	
17		. Cutter - R.H.	
18		. Center Link	

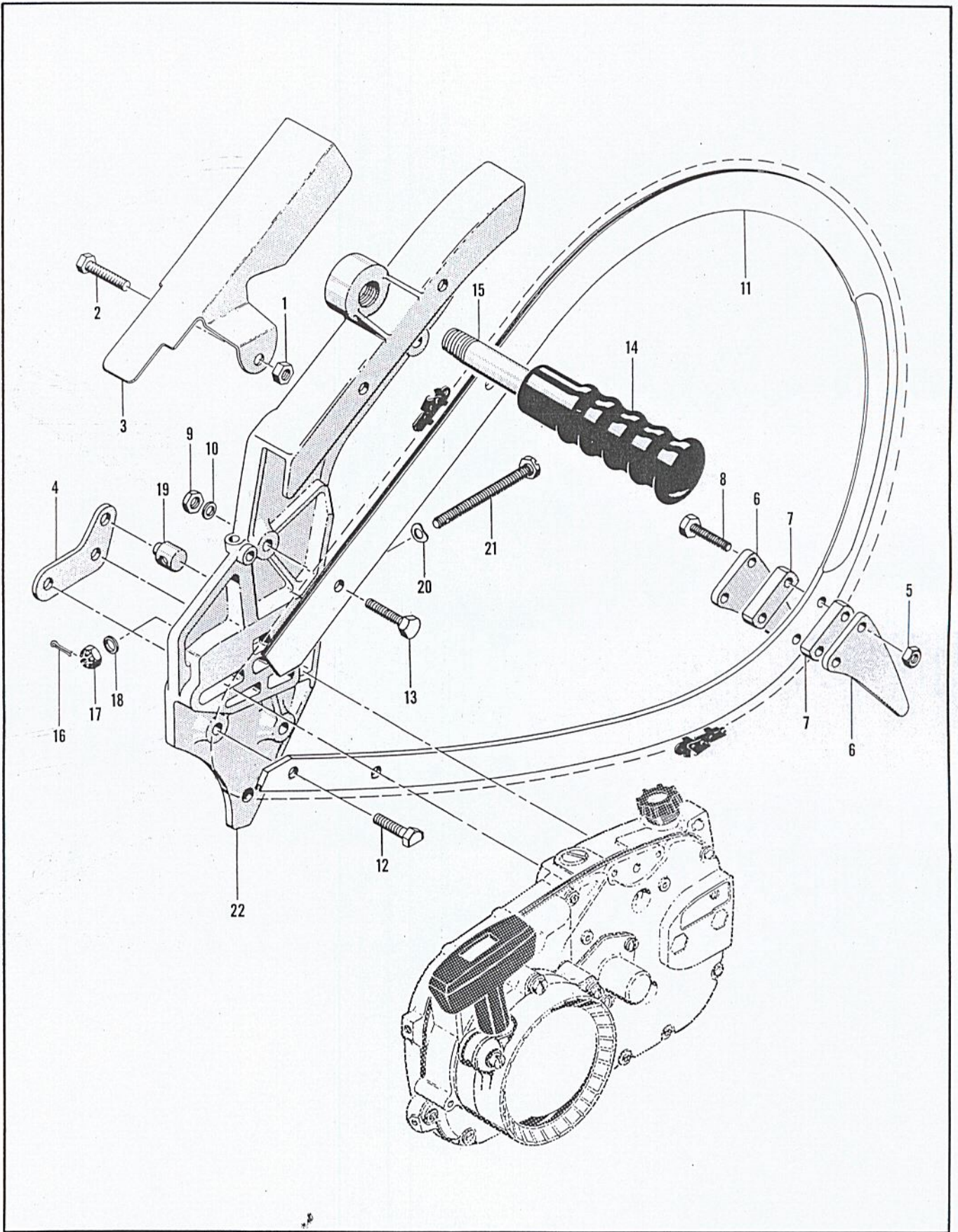

Figure 8. Plunge Bow Saw Assembly

FIGURE 8 PLUNGE BOW SAW ASSEMBLY

Index No.	Part Number	Nomenclature	Units Per Assy
	55152	Plunge Bow Saw Assy (less track)	1
1	*101143	. Nut - Hex 1/4-20	1
2	*102128	. Screw - Hex hd 1/4-20 x 1-1/4 in. lg	1
3	*51889	. Guard - Chain (Bow saw)	1
4	*51674	. Plate - Adjusting	1
5	*101143	. Nut - Hex 1/4-20	2
6	*28256	. Spike	2
7	*28259	. Spacer	2
8	*102130	. Bolt - Hex hd 1/4-20 x 1-1/2 in. lg	2
9	*101143	. Nut - Hex 1/4-20	4
10	*100004	. Washer - Plain 1/4 in.	4
11		. Track (available through dealers)	
12	*51955	. Bolt - Special 1/4-20 x 1 in. lg	1
13	*101982	. Bolt - Hex hd 1/4-20 x 1 in. lg	3
	*19502	. Auxiliary Handle Assy	1
14	*18207A	. . Grip - Handle	1
15	*19476	. . Auxiliary Handle	1
16	101495	. Pin - Cotter 0.09 in. dia x 0.50 in. lg	1
17	102022	. Nut - Castle 5/16-24	1
18	100007	. Washer - Plain 5/16 in.	1
19	19708	. Nut - Adjusting	1
20	24260	. Spring - Thrust	1
21	102193	. Screw - Adjusting	1
22	51672	. Body Assy	1

*Contained in loose parts package.

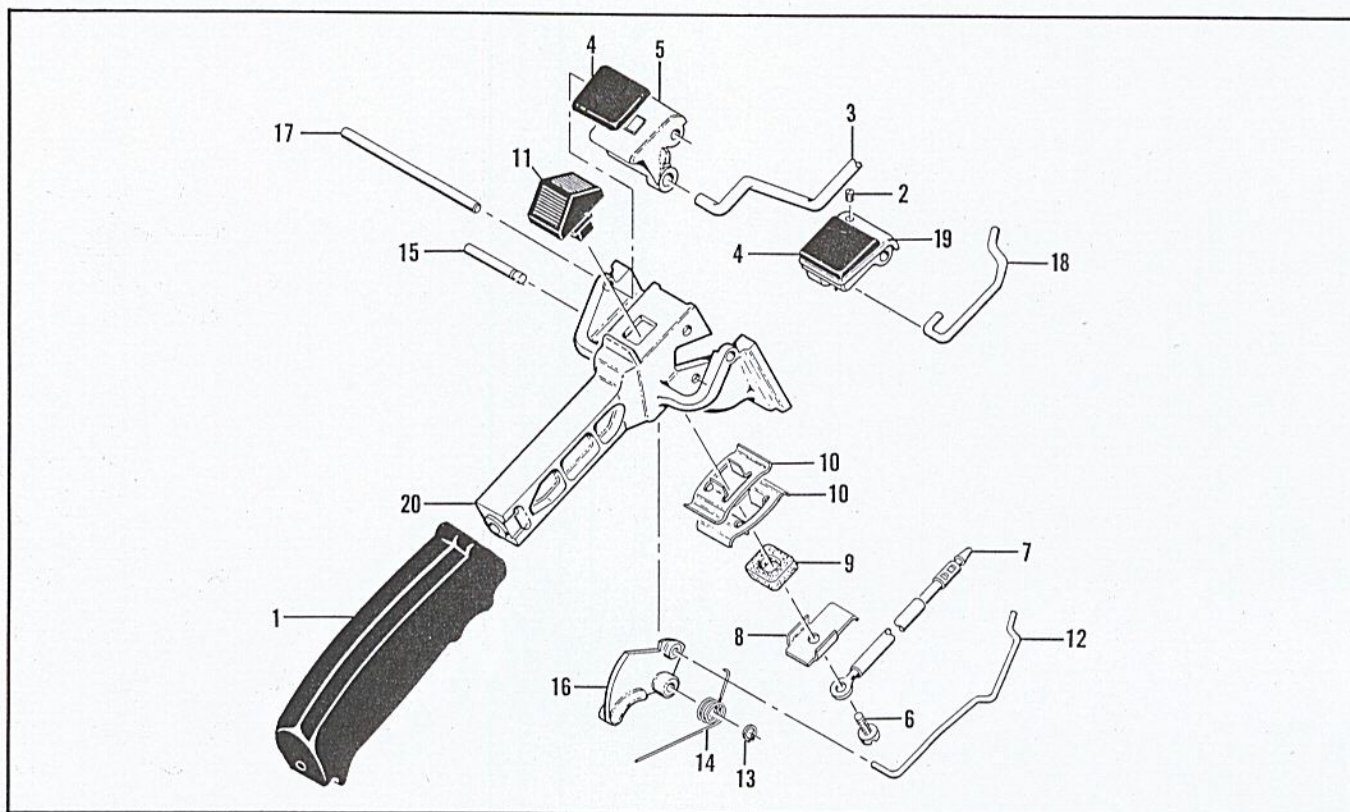

Figure 9. Handle and Control Assembly

FIGURE 9 HANDLE AND CONTROL ASSEMBLY

Index No.	Part Number	Nomenclature	Units Per Assy
	57739	Handle and Control Assembly	1
1	55624A	. Grip - Handle	1
2	104484	. Screw - Set 8-32 x 1/4 in. lg	1
3	57719	. Pushrod - Oiler	1
4	55670	. Grommet	2
5	55969A	. Button - Oiler control (Item 47, Figure 4)	1
6	103061	. Screw - Fil hd 8-32 x 3/8 in. lg (SEMS)	1
7	51492A	. Wire Assy - Primary	1
8	51279	. Contact - Switch	1
9	51555	. Insulator - Switch	1
10	51554A	. Detent - Switch	2
11	57718	. Button - Switch	1
12	55873	. Pushrod - Throttle	1
13	104501	. Retainer - Trigger pin	1
14	55674	. Spring - Trigger return	1
15	50507	. Pin - Trigger	1
16	55616	. Trigger	1
17	51344A	. Shaft - Choke and oiler	1
18	55675A	. Pushrod - Choke	1
19	55968A	. Button - Choke control	1
20	55986	. Handle	1

TOOLS AND ACCESSORIES

Index No.	Part Number	Nomenclature	Units Per Assy
	*51445	Wrench and Screwdriver Combination	
	*57806	Owner's Manual of Operating Instructions	
	*57810	Illustrated Parts List	
	*56625A	Chain Maintenance Manual	
	14168A	Wrench - Spark plug	
	18413A	Gauge - Feeler	
	101259	Grinder - Chain	
	102094	Fixture - Chain grinding	
	102449	McCulloch Yellow Paint (12 oz spray bomb type)	
	102057	McCulloch Oil (1 quart)	
	102664	McCulloch Oil (12 oz can)	
	102448	File - Round 9/32 in. dia.	
	101453	File - Round 1/4 in. dia	
	103028	Stones - Grinding 9/32 in. dia	
	103029	Stones - Grinding 1/4 in. dia	
	56224A	Chain Breaker - Rivet spinner	
	56250	Depth Gauge - .025 - .040	
	56251	Depth Gauge - .045 - .060	

*Indicates items furnished with each saw.

OVERSIZE PISTON ASSEMBLY

Index No.	Part Number	Nomenclature	Units Per Assy
	48685	Piston Assembly - .020 oversize	
	48693	... Ring - Piston (set of 2) .020 oversize	