

Chain Saw

MODEL 200

(P/N 60280A)

ILLUSTRATED PARTS LIST

MARCH 1964

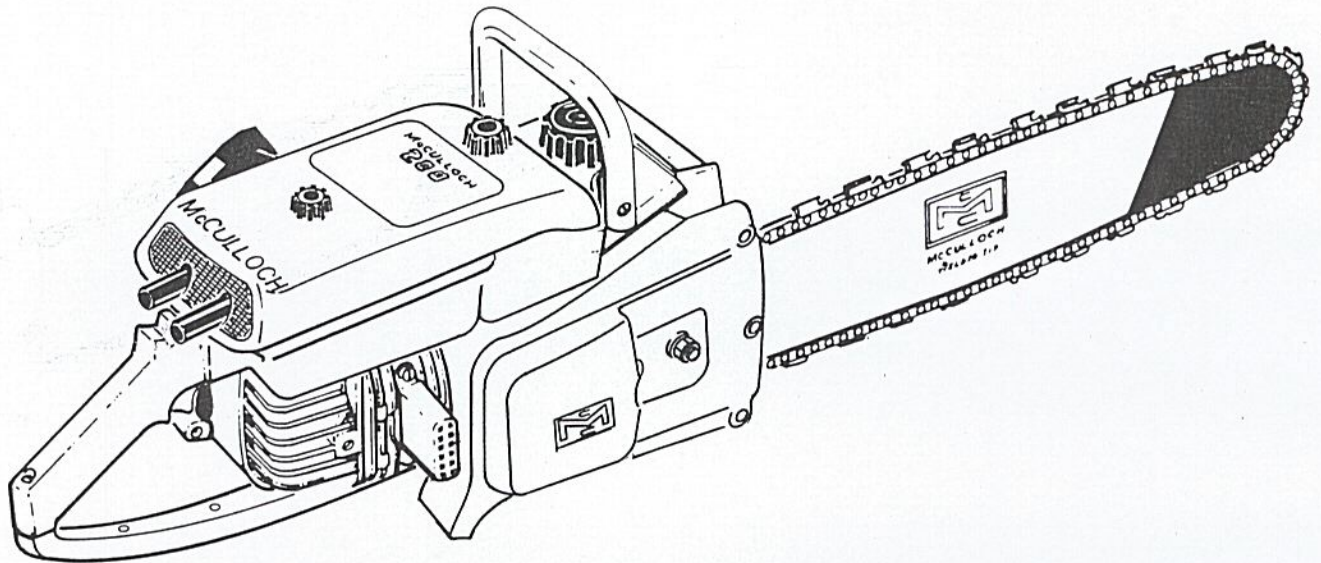

The following pages contain an illustrated parts list for the Model 200 Chain Saw Serial No. 38001 and up. It is important that the Serial Number of your saw be included whenever spare parts are ordered.

The McCulloch Corporation reserves the right to modify or change specifications without (1) prior notification or (2) obligation including the obligation to back-fit or supply back-fit components for units previously shipped from the factory.

	Page
Figure 1. General Exploded View	2
Figure 2. Starter and Crankcase Cover Assemblies	4
Figure 3. Oiler and Fuel Tank Assemblies	6
Figure 4. Cover and Airbox Assemblies	8
Figure 5. Carburetor	10
Figure 6. Powerhead	12
Figure 7. Clutch Guard, Bar and Chain	14



McCULLOCH CORPORATION

6101 West Century Boulevard,
Los Angeles 45, California

MODEL
200

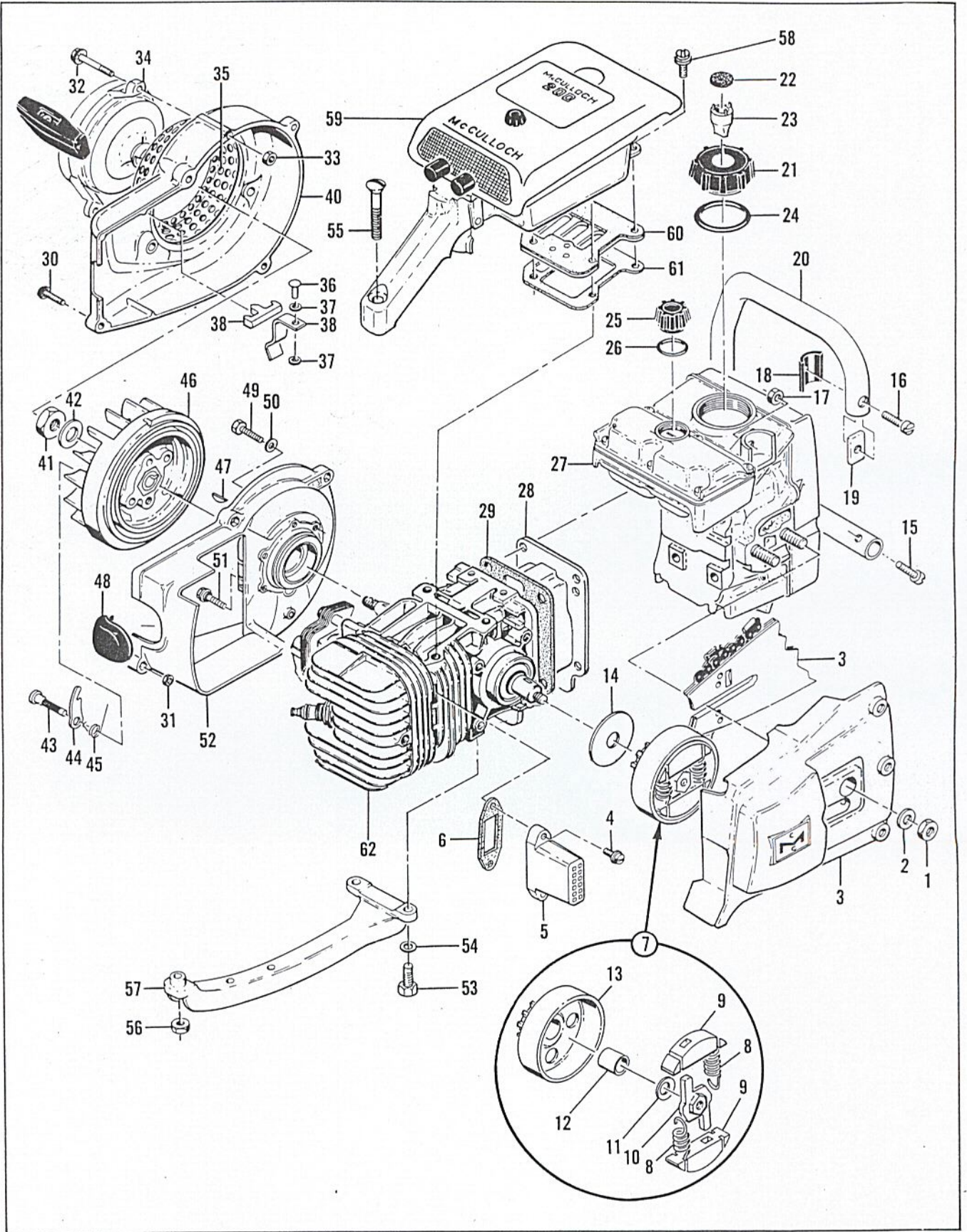

Figure 1. General Exploded View

FIGURE 1. GENERAL EXPLODED VIEW

Index No.	Part Number	Nomenclature	Units Per Assy
1	103729	Nut - Hex 3/8-24	2
2	100006	Washer - Plain 3/8 in.	2
3		Clutch Guard, Bar and Chain (See Figure 7)	1
4	104840	Screw - Hex hd 10-24 x 3/4 in. lg.	2
5	50115	Pipe - Exhaust	1
6	53652	Gasket - Exhaust	1
7		Clutch and Sprocket, Drum and Bushing Assys	1
	52844	Clutch Assy	1
8	52847	. Spring - Clutch Shoe	2
9	52845	. Shoe - Clutch	2
10	52846	. Rotor Assy - Clutch	1
11	101270	Washer - Plain 7/16 in.	1
	50129A	Sprocket, Drum and Bushing Assy	1
12	50128	. Bushing	1
13	51775B	. Sprocket and Drum Assy	1
14	50132	Washer - Sprocket Assy	1
15	102356	Screw - Fil hd 1/4-20 x 7/8 in. lg	2
16	100416	Screw - Fil hd 1/4-20 x 1 in. lg	1
17	101143	Nut - Hex 1/4-20	3
18	50062	Insulator - Frame	3
19	57133	Saddle - Frame	3
20	50061B	Frame	1
21	55934B	Cap - Fuel	1
22	55063	. Filter - Fuel cap	1
23	53766A	. Valve - Fuel cap	1
24	101348	"O" Ring	1
25	57129A	Cap - Oiler	1
26	101148	"O" Ring	1
27		Oiler and Fuel Tank Assys (See Figure 3)	1
28	53399C	Cover - Crankcase bottom	1
29	58166A	Gasket - Bottom	1
30	104815	Screw - 10-24 x 7/8 in. lg (SEMS)	4
31	101191	Nut - Hex 10-24	2
32	104815	Screw - 10-24 x 7/8 in. lg (SEMS)	3
33	101191	Nut - Hex 10-24	3
34		Starter Assy (See Figure 2)	1
35	50581A	Guard - Sawdust	1
	57184B	Fan Housing Assy	1
36	103819	. Rivet ov 3/16 x 5/16	1
37	24236	. Washer - Special	2
38	50818	. Spring - Switch	1
39	50817	. Button - Switch	1
40		. Fan Housing (Order Fan Housing Assy #57184B)	1
41	101179	Nut - Hex 7/16	1
42	101270	Washer - Special	1
43	36144B	Pin - Pawl	2
44	24093	Pawl - Starter	2
45	50582	Spring - Pawl	2
46	48785C	Flywheel Assy	1
47	103879	Key - Woodruff #3	1
48	57565	Cover Assy - Spark plug	1
49	102289	Screw - Hex hd 10-24 x 3/4 in. lg	4
50	102189	Washer - Plain #10	3
51	55494	Screw - Sealing	2
52		Crankcase Cover Assy (See Figure 2)	1
53	100992	Screw - Hex hd 1/4-20 x 3/4 in. lg	2
54	100004	Washer - Plain 1/4	2
55	104435	Screw - Oval head 10-24 x 1-3/4 in. lg	1
56	101191	Nut - Hex 10-24	1

This list continued on page 5

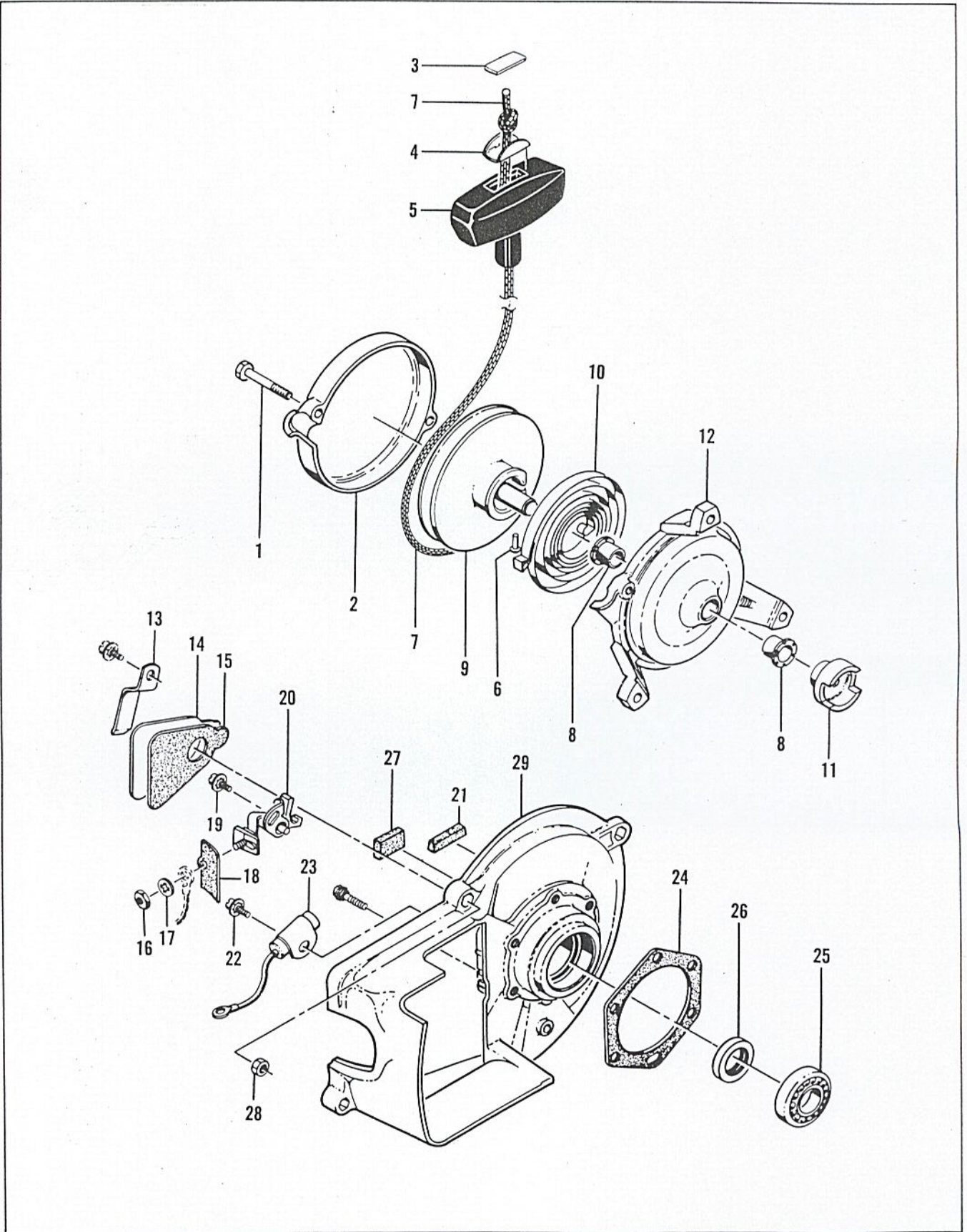

Figure 2. Starter and Crankcase Cover Assemblies

FIGURE 1. GENERAL EXPLODED VIEW (CONT)

Index No.	Part Number	Nomenclature	Units Per Assy
57	50041	Brace - Handle	1
58	110127	Screw - Hex hd 10-24 x 7/8 in. lg (SEMS)	2
59		Cover and Airbox Assemblies (See Figure 4)	1
60		Reed Plate Assy (See Figure 4)	1
61	57657A	Insulator - Reed plate	1
62		Powerhead (See Figure 6)	1

FIGURE 2. STARTER AND CRANKCASE COVER ASSEMBLIES

Index No.	Part Number	Nomenclature	Units Per Assy
	60130	Starter Assy	1
1	104396	. Screw - 10-24 x 3/4 in. lg.	2
2	60647	. Cover - Starter	1
3	57232	. Plate - Starter handle	1
4	57231	. Cup - Starter handle	1
5	57230	. Handle - Starter	1
6	101136	. Rivet	1
7	28716	. Rope - Starter	1
8	57535	. Bushing	2
9	57792	. Drum - Starter	1
10	51665	. Spring - Rewind	1
11	57790	. Ratchet - Starter	1
12	60646	. Base - Starter	1
13	50671	Retainer - Breaker box cover	1
14	50588	Cover - Breaker box	1
15	50589	Gasket - Breaker box	1
16	100251	Nut - Hex 8-32	1
17	100057	Lockwasher - #8	1
18	50381A	Insulator - Breaker terminal	1
19	103672	Screw - Hex hd 8-32 x 1/2 in. lg. (SEMS)	1
20	50076A	Breaker Assy	1
21	50664	Felt - Breaker box	1
22	103672	Screw - Hex hd 8-32 x 1/2 in. lg. (SEMS)	1
23	50074	Condenser	1
24	51240	Gasket - Crankcase	1
25	100824	Bearing - Ball	1
	57126A	Crankcase Cover Assy	1
26	50663	. Seal - Oil	1
27	54184	. Wiper - Felt	1
28	101326	. Nut - Hex 10-24	2
29		. Cover - Crankcase (Order Crankcase Cover Assy #57126A)	1

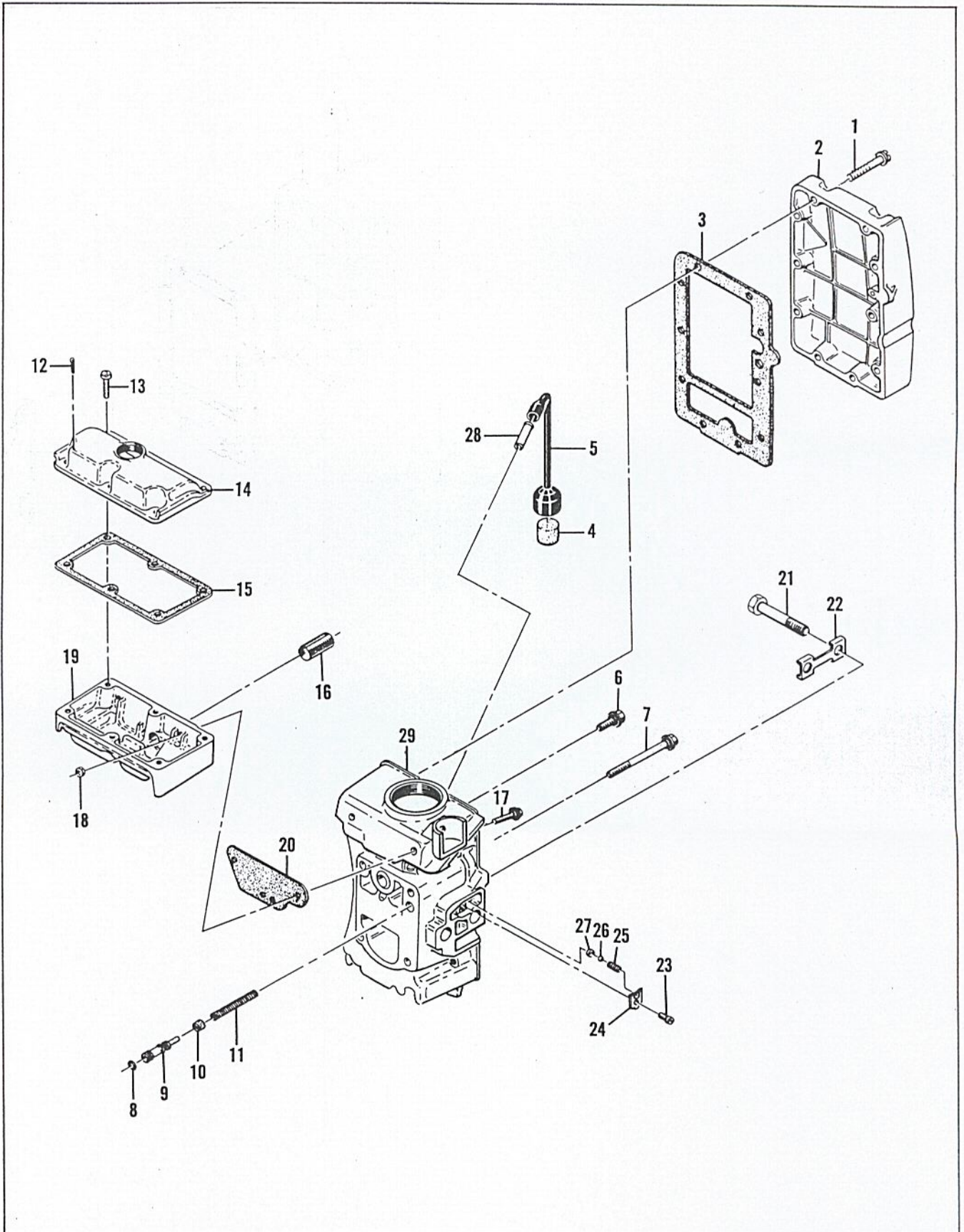

Figure 3. Oiler and Fuel Tank Assemblies

FIGURE 3. OILER AND FUEL TANK ASSEMBLIES

Index No.	Part Number	Nomenclature	Units Per Assy
1	104396	Screw - Pan hd 10-24 x 3/4 in. lg.	10
2	60781	Cover - Fuel tank	1
3	50034B	Gasket - Fuel tank	1
4	50124A	Filter - Fuel tank	1
5	50082	Hose - Fuel	1
6	57840	Screw Assy - Sealing	3
7	50569	Screw Assy - Sealing	1
8	101056	"O" Ring	1
9	57148	Piston - Oiler	1
10	24104A	Cup - Oiler piston	1
11	18349A	Spring - Oiler	1
12	100010	Pin - Cotter 1/16 x 1/2	1
13	104395	Screw - Pan hd 10-24 x 5/8 in. lg.	6
14	57114A	Cover - Oil tank	1
15	57152	Gasket - Oil tank cover	1
16	57279	Screen - Oil tank	1
17	55494	Screw Assy - Sealing	3
18	101326	Nut - Hex 10-24	3
19	57112A	Tank - Oiler	1
20	57147	Gasket - Oiler tank	1
	57976A	Fuel Tank Assy	1
21	57217	. Bolt - Bar mounting	2
22	51439	. Lockplate	1
23	110055	. Screw - Fil hd 8-32 x 3/8 in. lg (SEMS)	1
24	51941	. Retainer - Ball	1
25	51945	. Spring - Outlet	1
26	100549	. Ball - 3/16 in. dia	1
27	51943	. Seat - Ball valve	1
28	28042	. Tube - Fuel hose	1
29		. Tank - Fuel (Order Fuel Tank Assy #57976A)	1

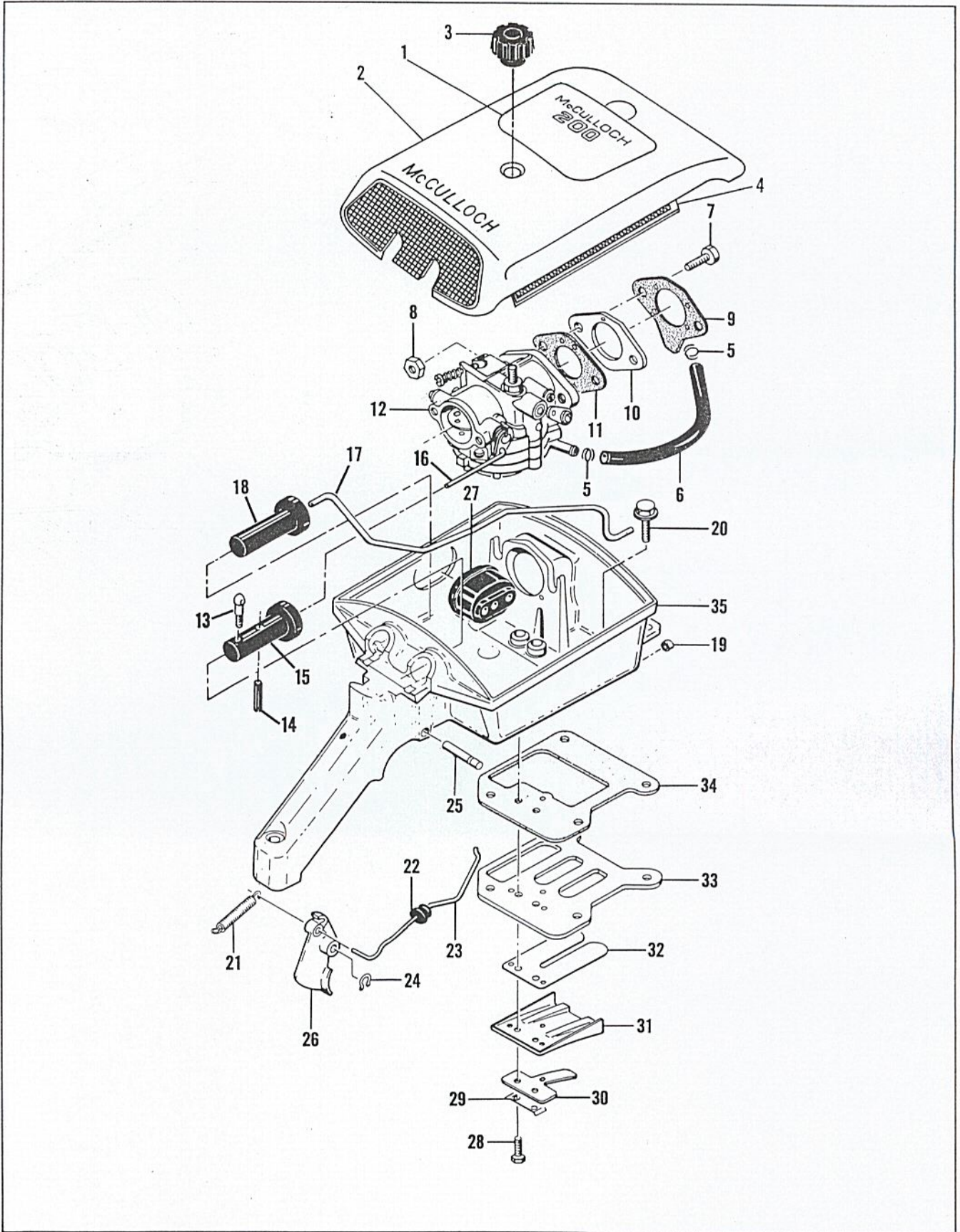

Figure 4. Cover and Airbox Assemblies

FIGURE 4. COVER AND AIRBOX ASSEMBLIES

Index No.	Part Number	Nomenclature	Units Per Assy
1	61389	Nameplate	1
2	60342	Cover Assy - Air cleaner	1
3	60242	. Knob - Air cleaner attaching	1
4	55497	Screen - Air cleaner	1
5	50742	Clamp - Fuel hose	2
6	50097	Hose - Fuel	1
7	53539	Screw - Hex hd 1/4-20 x 15/16 in. lg	2
8	103242	Nut - Hex 1/4-20	2
9	50123B	Gasket - Adapter to airbox	1
10	50686A	Adapter - Carburetor	1
11	55519A	Gasket - Carburetor	1
12	50687D	Carburetor Assy (See Figure 5)	1
13	50776	Screw - Special	1
14	101556	Pin - Roll	1
15	50777B	Button - Choke	1
16	57134	Push Rod - Choke	1
17	57062	Pushrod - Oiler	1
18	50591B	Button - Oiler	1
19	55449A	Washer - Felt	1
20	110127	Screw - Hex hd 10-24 x 7/8 in. lg (SEMS)	2
	57449E	Air Box Assy	1
21	36449	. Spring - Throttle	1
22	60237	. Grommet - Throttle	1
23	50684	. Rod - Throttle	1
24	104501	. Retainer - Trigger pin	1
25	50507	. Pin - Trigger	1
26	50091B	. Trigger	1
27	57105	. Grommet - Carburetor control	1
28	103740	. Screw - Hex hd 8-32 x 5/8 in. lg	2
29	51480	. Lockplate	1
30	57658	. Clamp - Reed	1
31	57654	. Deflector - Fuel	1
32	58399	. Valve - Reed	1
33	57656C	. Plate - Reed	1
34	57145A	. Gasket - Airbox	1
35		. Airbox (Order Airbox Assy #52449E)	1

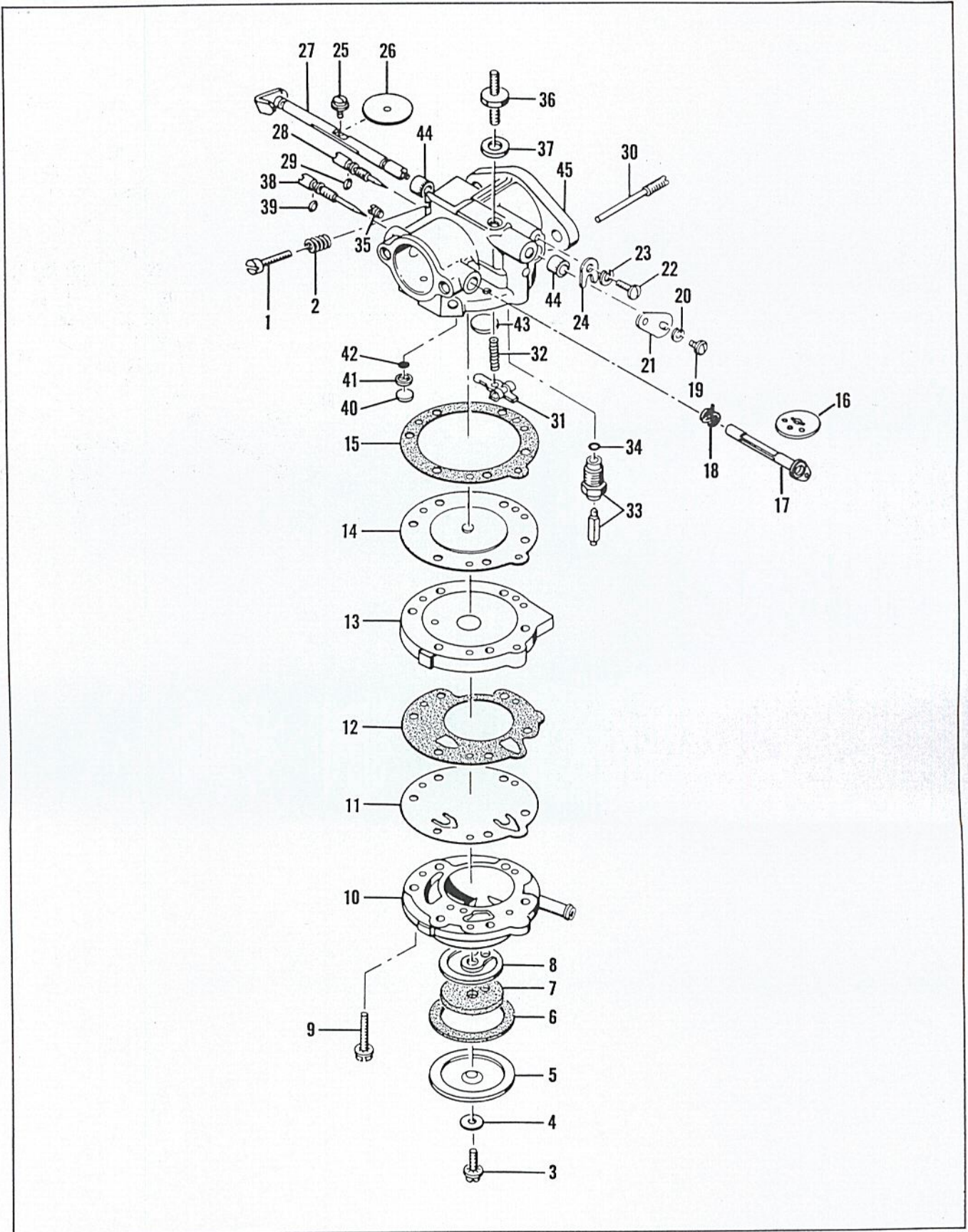

Figure 5. Carburetor

FIGURE 5. CARBURETOR

Index No.	Part Number	Nomenclature	Units Per Assy
	50687D	Carburetor Assy	1
1	*50799	. Screw - Idle speed regulating	1
2	*51705	. Spring - Idle speed regulating screw	1
3	*50797	. Screw - Fuel filter cover	1
4	50798	. Gasket - Fuel filter cover	1
5	50796	. Cover - Fuel filter	1
6	51704	. Gasket - Fuel filter cover	1
7	*53717	. Filter Element - Fuel	1
8	53565	. Gasket - Fuel filter	1
9	51597	. Screw - Fuel pump body	6
10	50670	. Body - Fuel pump	1
11	53164	. Diaphragm - Fuel pump	1
12	51594	. Gasket - Fuel pump	1
13	51592	. Cover - Diaphragm	1
14	*51590A	. Diaphragm Assy	1
15	51591A	. Gasket - Diaphragm	1
16	53813	. Shutter - Choke	1
17	53814	. Shaft and Lever - Choke	1
18	51586	. Spring - Choke shaft return	1
19	*51719	. Screw - Throttle governor lever	1
20	100261	. Lockwasher	1
21	51718	. Lever - Throttle governor	1
22	*51717	. Screw - Throttle shaft clip	1
23	*100252	. Lockwasher	1
24	51716	. Clip - Throttle shaft	1
25	*51721	. Screw - Throttle shutter	1
26	51720	. Shutter - Throttle	1
27	50803A	. Throttle Shaft and Lever	1
28	*51702	. Needle Assy - Idle adjustment	1
29	51703	. "O" Ring	1
30	*51710	. Screw - Inlet control lever pinion	1
31	*51709	. Lever - Inlet control	1
32	*51711	. Spring - Inlet tension	1
33	*51707A	. Seat and Needle Assy	1
34	51708	. Gasket - Inlet seat	1
35	51589	. Drain Screw - Diaphragm chamber	1
36	50785	. Stud - Air cleaner attachment	1
37	50786A	. Gasket - Stud	1
	50779C	. Body and Needle Assy - Carburetor	1
38	*53718	. Needle Assy - Main adjustment	1
39	51703	. "O" Ring	1
40	*57653	. Plug - Channel cup	1
41	57652	. Ring - Retainer	1
42	57651	. Screen	1
43	*51583	. Plug - Welch	1
44	51715	. Bushing - Shaft	2
45		. Body(Order Carburetor Body Assy #50779C)	1
45	*50806	Gasket and Packing Set	1
	53719	Repair Parts Kit	1

*Indicates part in Repair Parts Kit #53719

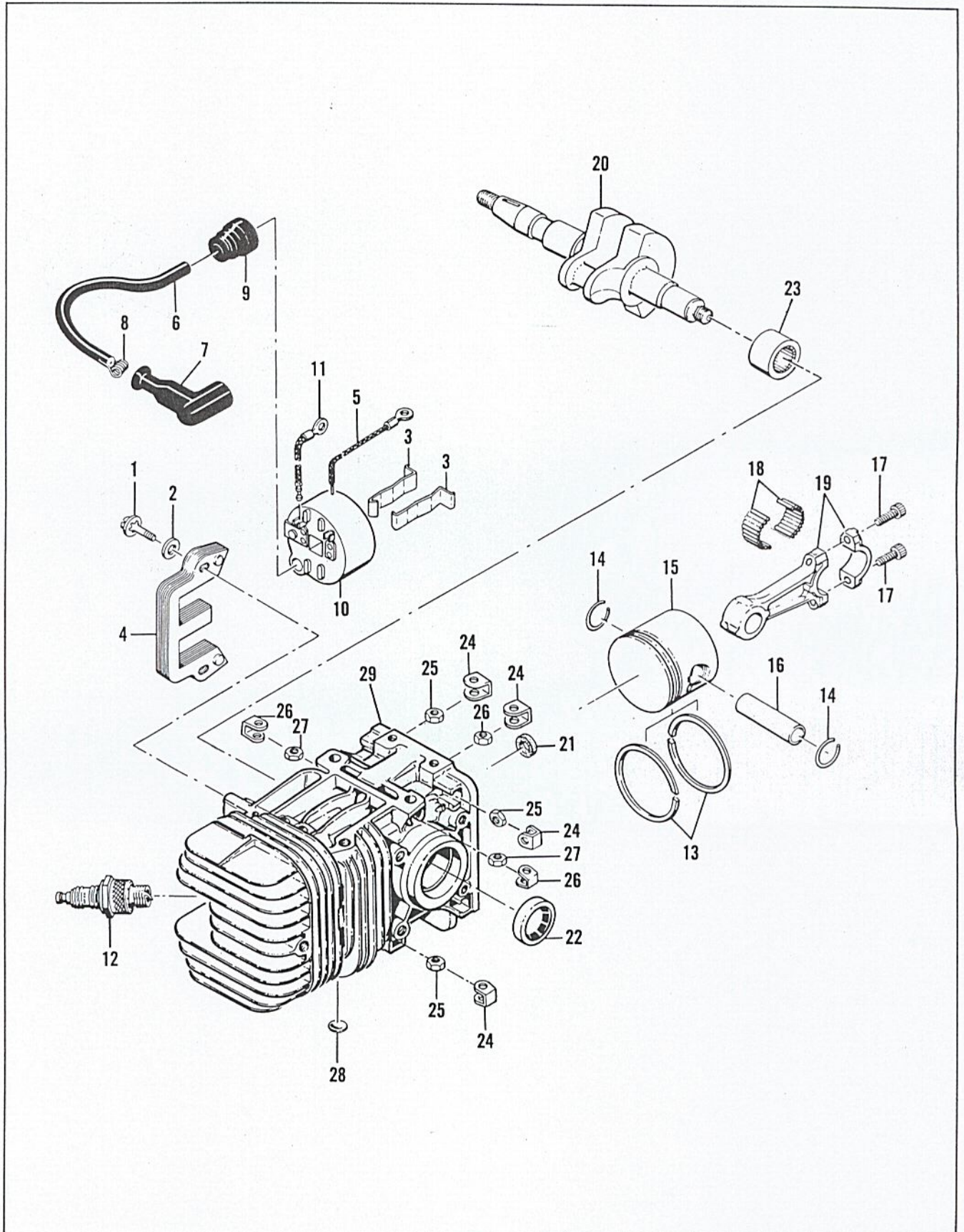

Figure 6. Powerhead

FIGURE 6. POWERHEAD

Index No.	Part Number	Nomenclature	Units Per Assy
1	104815	Screw - Hex hd 10-24 x 7/8 in. lg.	2
2	102189	Washer - Plain #10	2
3	51253	Retainer - Coil	2
4	51251	Lamination Assy	1
	55949A	Coil and Terminal Assy	1
5	101883	. Wire Assy - Ground	1
6	52547	. Wire Assy - Spark plug	1
7	55060	. . Boot - Spark plug	1
8	55061	. . Connector	1
9	55617	. Nipple - Spark plug wire	1
10		. Coil Assy (Order Coil and Terminal Assy #55949A)	1
11	57225	Wire Assy - Primary	1
12		Spark Plug - 14 mm	1
	50206	Piston Assy (For service replacement)	1
13	55123	. Ring Set - Piston (Set of 2 rings)	1
14	50133	. Ring - Retaining	2
15		. Piston (Order Service Replacement Piston Assy #50206)	1
16	50207A	Pin - Piston	1
	47782A	Rod Assy - Connecting	1
17	60210A	. Screw - Socket hd 10-32 x 0.552 in. lg	2
18	102742	. Roller - Needle	24
19		. Rod - Connecting (Order Rod Assy #47782A)	1
20	50659A	Crankshaft	1
21	55449A	Washer - Felt	1
	52886A	Cylinder Assy - Crankcase	1
22	104128	. Seal - Oil	1
23	104129	. Bearing - Needle	1
24	18556A	. Retainer - Nut	6
25	103242	. Nut - Hex 1/4-20	6
26	28053	. Retainer - Nut	2
27	101191	. Nut - Hex 10-24	2
28	110179	. Plug - Expansion	2
29		. Cylinder - Crankcase (Order Cylinder Assy #52886A)	1

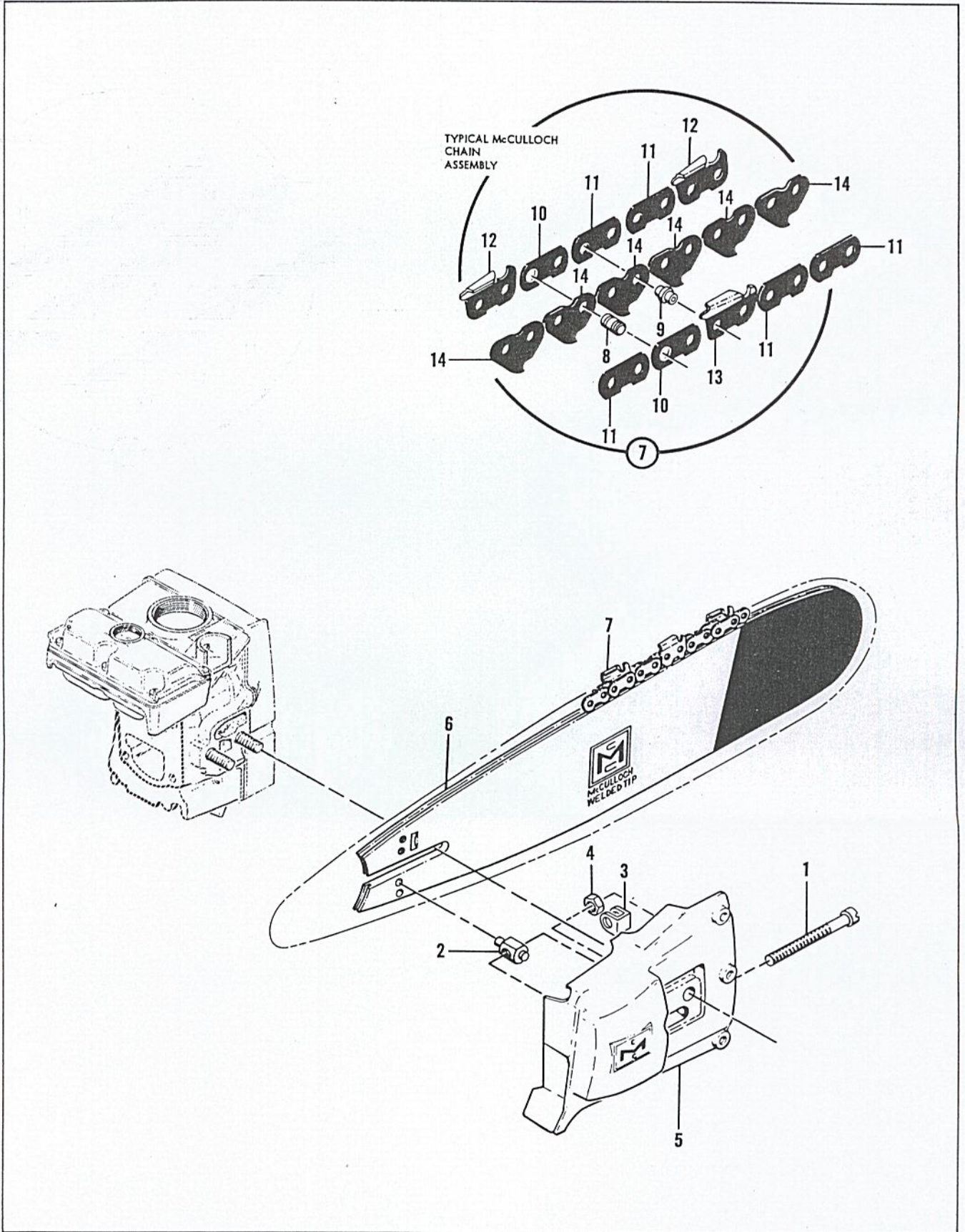

Figure 7. Clutch Guard, Bar and Chain

FIGURE 7. CLUTCH GUARD, BAR AND CHAIN

Index No.	Part Number	Nomenclature	Units Per Assy
	60133	Guard Assy - Clutch	1
1	53853	. Screw - Fil hd 1/4-28 x 3.47 in. lg.	1
2	52207C	. Nut - Bar adjusting	1
3	18556A	. Retainer - Nut	1
4	110227	. Nut - Hex 1/4-28	1
5	60134	. Guard - Clutch	1
6	52551	Bar - Flame hardened 18 in. lg	1
	51405A	Bar - Hard-faced 18 in. lg	Alternate
	51407A	Bar - Hard-faced 24 in. lg	Alternate
	50606	Laminated Bar - Hard-faced 18 in. lg	Alternate
	50347	Laminated Bar - Flame hardened 18 in. lg	Alternate
	50346	Laminated Bar - Hard-faced 18 in. lg	Alternate
	50348	Laminated Bar - Hard-faced 24 in. lg	Alternate
7		Typical McCulloch Chain Assy	
8		. Master Pin	
9		. Rivet	
10		. Master Side Link	
11		. Side Link	
12		. Cutter - Left side	
13		. Cutter - Right side	
14		. Center Link	

TOOLS, PARTS AND ACCESSORIES

Part Number	Nomenclature
*51445A	Wrench and Screwdriver - Combination
*61390	Owner's Manual
*56625B	Chain Maintenance Manual
61331	Kit - 4-tooth spike
61330	Kit - 5-tooth spike
18413A	Feeler Gauge
102094	Chain Grinding Fixture
56224	Chain Breaker - River Spinner
56250	Depth Gauge Tool - 0.025 to 0.040 in. depth
56251	Depth Gauge Tool - 0.045 to 0.060 in. depth
50134	Piston Assy - 0.020 in. oversize
55125	. Ring Set - 0.020 in. oversize (Set of two rings)
50133	. Ring - Retaining

*Items furnished with each saw.