

# ILLUSTRATED PARTS LIST

## DOUBLE EAGLE™ 80 CHAIN SAW

MODELS	SERIAL NUMBER PREFIX
600155D	11-

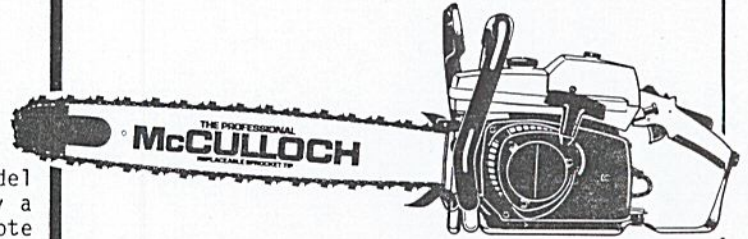

McCulloch Chain Saws are identified by a model number (in this instance 600155) followed by a suffix number (04). Suffix numbers denote variations in parts or assemblies used in the manufacture of this product.

Part numbers listed in this I.P.L. which have a circled number ② or numbers preceding the description, are used only on the model or models identified by a circled number ② or numbers.

Part numbers which have one or more dots (.) preceding their descriptions may be ordered individually, but they are also included in the kit or assembly whose description begins directly above the dot(s).

The policy of McCulloch Corporation is one of continual improvement in design, manufacturing and engineering advancement wherever possible to assure still finer power tools. Hence, specifications, equipment, colors, design and manufacturer's suggested list prices are subject to change without notice and McCulloch Corporation reserves the right to make such changes without prior notification or obligation to backfit or supply backfit components for units previously shipped from the factory.

### - CONTENTS -

	Page
Figure 1. General . . . . .	2
Figure 2. Bar/Chain/Chain Sharpening Tools	3
Figure 3. CHAIN BRAKE Assembly. . . . .	4
Figure 4. Fan Housing & Starter Asys . . . . .	5
Figure 5. Accessories . . . . .	5
Figure 6. Service Specifications. . . . .	5
Figure 7. Fuel Tank Assembly. . . . .	6
Figure 8. Carburetor Assembly . . . . .	7
Figure 9. Powerhead & Oiler Assemblies. . . . .	8

**MARCH 1987**





Figure 1 GENERAL ASSEMBLY

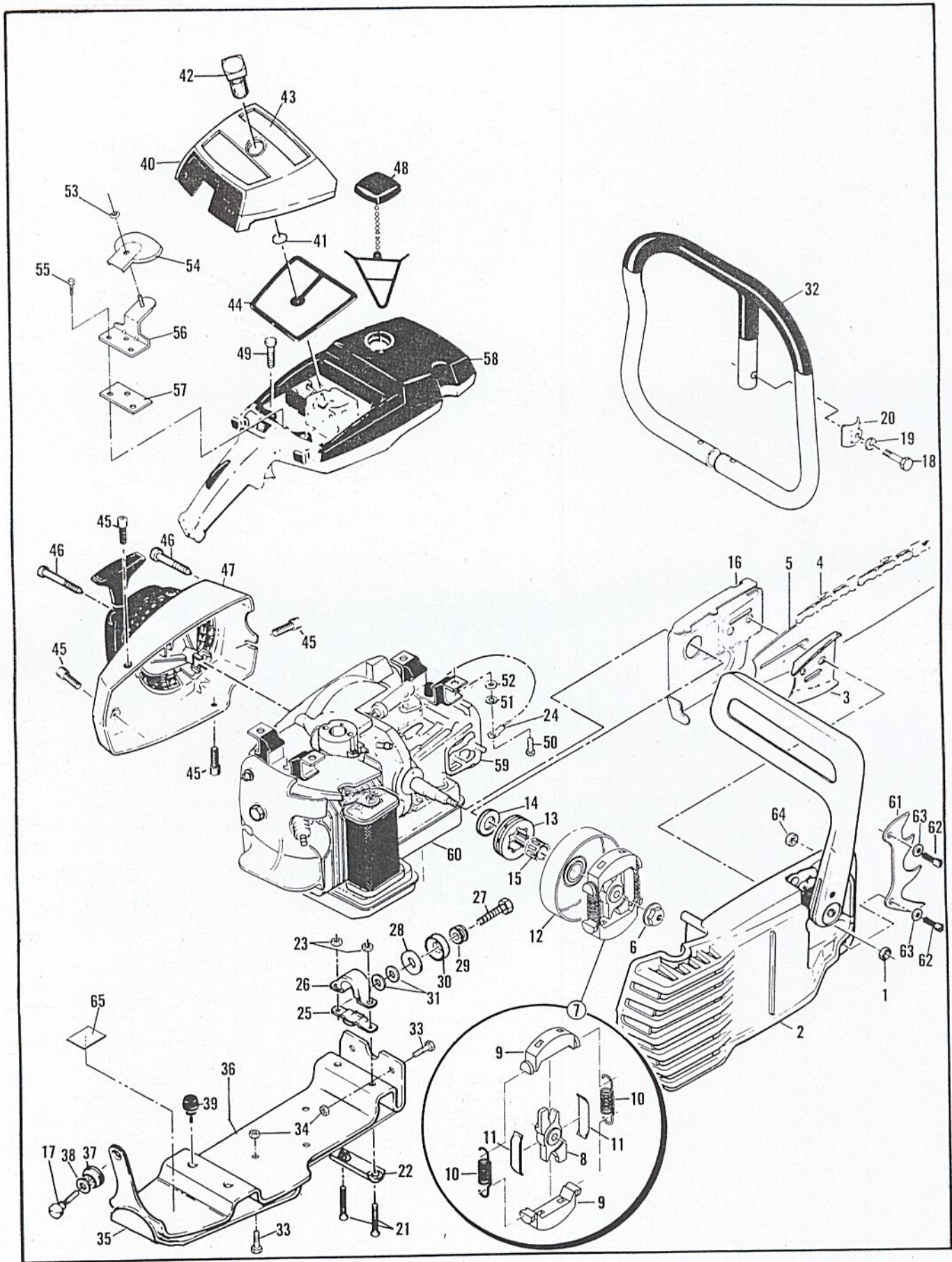



FIGURE 1 GENERAL ASSEMBLY

ITEM NO.	PART NUMBER	DESCRIPTION	UNITS PER ASY.	ITEM NO.	PART NUMBER	DESCRIPTION	UNITS PER ASY.
1	216645	Nut - M8 Hx Flange	2	34	216649	Nut - Hx Lock 10-24	5
2	Fig. 3	CHAIN BRAKE Asy	1	35	216103	Shield - Frame Brace	1
3	64325	Plate - Bar Guide	1	36	216090	Brace - Frame	1
4	Fig. 2	Chain Assembly	1	37	93032	Grommet - Frame Brace	1
5	Fig. 2	Bar Assembly	1	38	214764	Washer	1
6	86113	Nut - Hx 3/8-24 Left Hand (200-210 in. lb. torque)	1	39	89403	Bumper - Lower	2
7	214301	Clutch Assembly	1	40	95418	Cover Assembly - Air Cleaner	1
8	214300	. Rotor - Clutch	1	41	110565	. Ring Retaining	1
9	67233	. Kit - Clutch Shoe	1	42	95420	. Knob Cover	1
10	83223	. Spring - Clutch	2	43	218762	Label-Warning	1
11	64583	. Retainer - Clutch Spring	2	44	215681	Filter - Air	1
12	95166	Kit-Drum & Sprocket 7T .375P	1	45	216670	Screw - Skt 10-24 x .50 (40-45 in. lb. torque)	4
13	86344	. Sprocket - 7T .375P Rim	1	46	216624	Screw - Oval 8-32 x 2.26 (35-40 in. lb. torque)	3
14	86958	. Washer - Shim	1	47	Fig. 4	Fan Housing/Starter Asy	1
15	110971	Bearing - Sprocket	1	48	216053	Cap Assembly - Fuel	1
16	84978-01	Shield - Sawdust	1	49	110746	Screw Hx hd 10-24 x .50 Rear Mt (55-60 in. lb. torque)	2
17	213055	Screw - 10-24 x 1.50 (55-60 in. lb. torque)	1	50	216644	Screw - Hx hd 1/4-20 x 5/8 (110-120 in. lb. torque)	2
18	216638	Screw - Hx hd 1/4-20 x 1-1/2 (90-100 in. lb. torque)	1	51	216542	Lockwasher - .250	2
19	216542	Lockwasher - .250	1	52	216646	Washer - .250	2
20	216639	Clamp - Frame	1	53	105603	"0" Ring - .114 x .070	1
21	103353	Screw - Hx hd 10-24 x 1.50	2	54	218612	Shield - Spit Back	1
22	95679	Clamp - Frame	1	55	110959	Screw Hex 8-32 x .50 (35-40 in. lb. torque)	3
23	216682	Nut - Hx Lock 10-24	2	56	218611	Bracket - Air Filter	1
24	83828-01	Wire Assembly - Ground	1	57	218598	Plate - Spacer	1
25	92701	Clamp-Lower Mount Bottom	1	58	Fig. 7	Fuel Tank Assembly	1
26	92700	Clamp-Lower Mount top	1	59	Fig. 9	Powerhead/Oiler	1
27	216648	Screw - Hx hd 1/4-20 x 2 90-100 in. lb. torque	1	60	Fig. 9	Muffler Assembly	1
28	216647	Washer - Plain	1	61	93668	Spike	1
29	84661	Grommet	1	62	213042	Screw - Skt 10-24 x .62	2
30	85898	Mount - Lower	1	63	216683-26	Washer - Special 10	2
31	95636	Washer - 1/4	2	64	216682	Nut - Hx Lock 10-24	2
32	95514	Frame & Grip Assembly	1	65	219058	Label - Safety	1
33	216634	Screw - Pn 10-24 x .50	5				

Bar/Chain/Chain Sharpening Tools

Figure 2

PART NO.	BAR DESCRIPTION	PART NO.	CHAIN DESCRIPTION	FILE PLATE NO.	7/32 ROUND FILE NO.	
					1 DOZ. PAK	TWIN PAK
94074	16" Speed Mac	88167-12	16" PM370GX 60 C.L.	218739	56698-23	219161
89502	16" Mac 10	88167-12	16" PM370GX 60 C.L.	218739	56698-23	219161
93778	20" Speed Mac	89979-12	20" SPR370GX 71 C.L.	218738	56698-23	219161
89503	20" Mac 10	89979-12	20" SPR370GX 71 C.L.	218738	56698-23	219161



**Figure 3** CHAIN BRAKE® ASSEMBLY

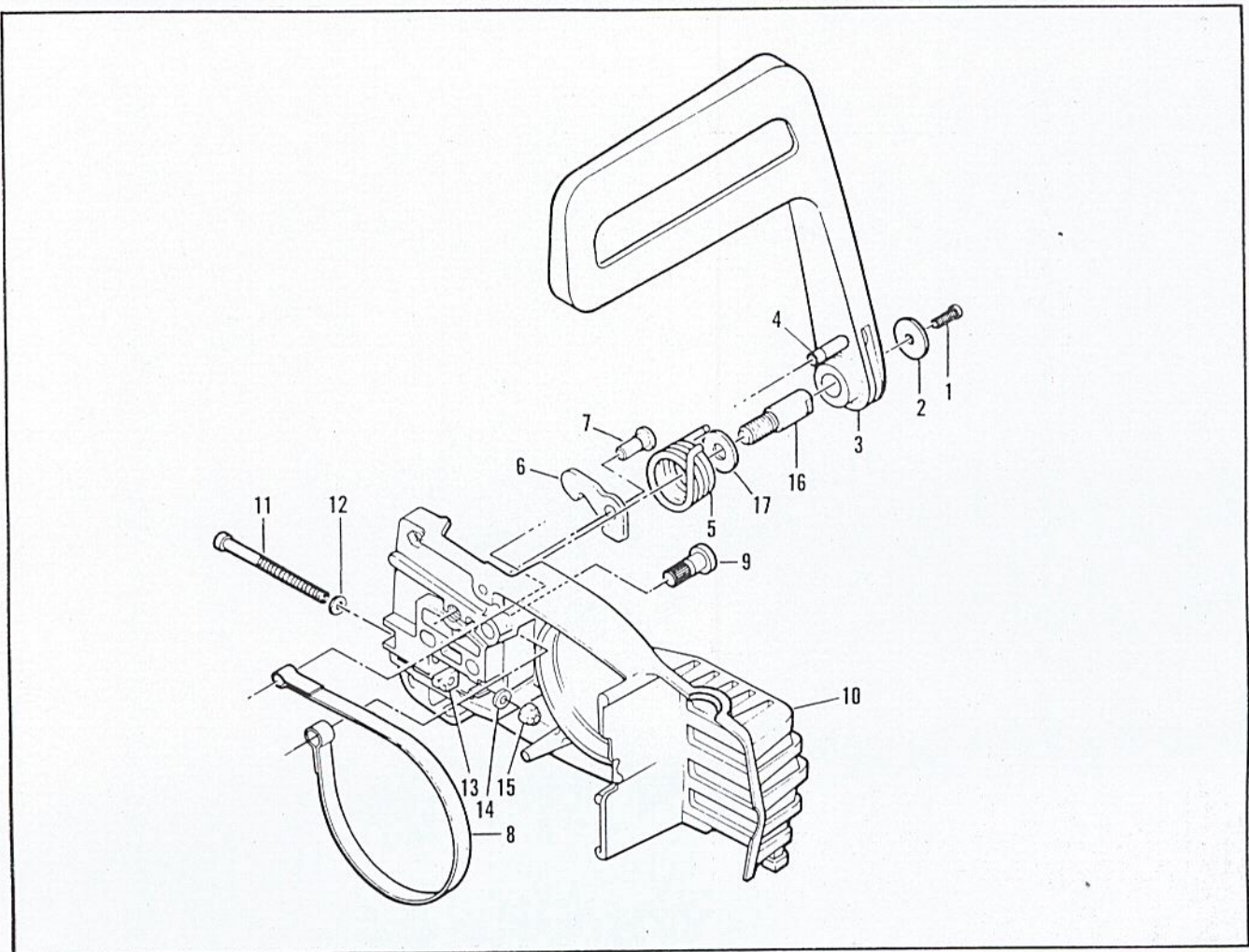

ITEM NO.	PART NUMBER	DESCRIPTION	UNITS PER ASY.
1	217695	CHAIN BRAKE® Assembly	1
	216634	. Screw-Pan hd 10-24 x .50	1
2	216633	. Washer .210 I.D.	1
3	215911	. Lever Assembly	1
4	214366	. Pin Assembly-Roller	1
5	93085	. Spring-Brake	1
6	217235	. Latch - Chain Brake	1
7	94144	. Pivot-Latch	1
8	93081	. Band-Brake	1

ITEM NO.	PART NUMBER	DESCRIPTION	UNITS PER ASY.
9	93082	. Pin-Band Anchor	1
10	215699	. Housing - Brake	1
11	216636	. Screw - Fil hd 10-24 x 2.75	1
12	216635	. Washer .203 I.D.	1
13	61705	. Nut-Bar Adjusting	1
14	100002	. Washer - #10	1
15	102067	. Nut-Hx 10-24	1
16	91246	. Pin-Lever Pivot	1
17	91245	. Washer - Thrust	1



# FAN HOUSING & STARTER

Figure 4

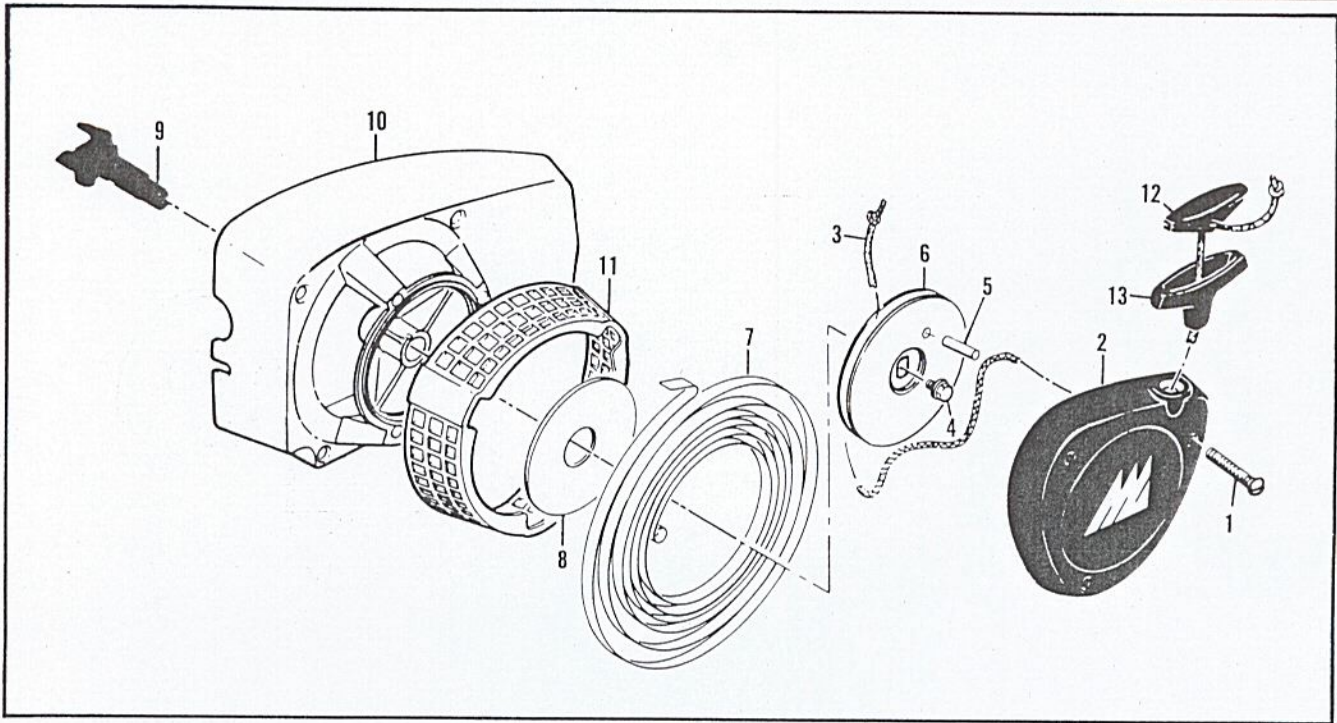

ITEM NO.	PART NUMBER	DESCRIPTION	UNITS PER ASY.
1	215706	Fan Housing/Starter Asy	1
	216625	. Screw-Oval 10-24 x 1.25	3
2	215707	. Cover Assembly-Starter	1
3	87670	. Rope-Starter	1
4	110928	. Screw-Hx hd 10-24 x .50	1
5	105841	. Pin-Roll	1
6	87689	. Drum-Starter	1

ITEM NO.	PART NUMBER	DESCRIPTION	UNITS PER ASY.
7	87668	. Spring-Rewind	1
8	86053	. Shield - Spring	1
9	95412	. Shaft - Starter	1
10	215705	. Fan Housing	1
11	214192	. Guard - Sawdust	1
12	214699	Insert-Handle	1
13	93137	Handle-Starter	1

## ACCESSORIES

Figure 5

PART NUMBER	DESCRIPTION	PART NUMBER	DESCRIPTION
214221	Scrench - 13mm x 5/8	215697	Air Filter - Felt
84453	Kit-Piston Tools	216147	Key-Socket 1/8
63432	Spark Plug	216335	Key-Socket 3/32
62827	Wrench/Screwdriver	216063	Key-Socket 5/32
214194	Metal Lubri-gun	214283	Spark Screen & Cap Asy
214195	Plastic Lube Gun		

## SERVICE SPECIFICATIONS

Figure 6

DISPLACEMENT. . . . .	5.2 Cubic Inches (82cc)	OIL CAPCITY . . . . .	9.6 Fluid Ounces
BORE/STROKE . . . . .	2.062 x 1.500	FUEL CAPACITY . . . . .	25.6 Fluid Ounces
SPARK PLUG. . . . .	AC-CS42T/Champion - DJ6J	IGNITION. . . . .	Electronic
DRY WEIGHT. . . . .	17.5 Pounds (Power Unit Only)	CYLINDER TYPE . . . . .	Hard Chrome
BAR LENGTH. . . . .	16 Inches to 33 Inches	SPARK PLUG GAP. . . . .	.025 Inch
SPROCKET. . . . .	7-Tooth .375 Pitch Floating Rim	CLUTCH	
		ENGAGEMENT SPEED. . .	2800 to 3000 RPM



**Figure 7 FUEL TANK ASSEMBLY**

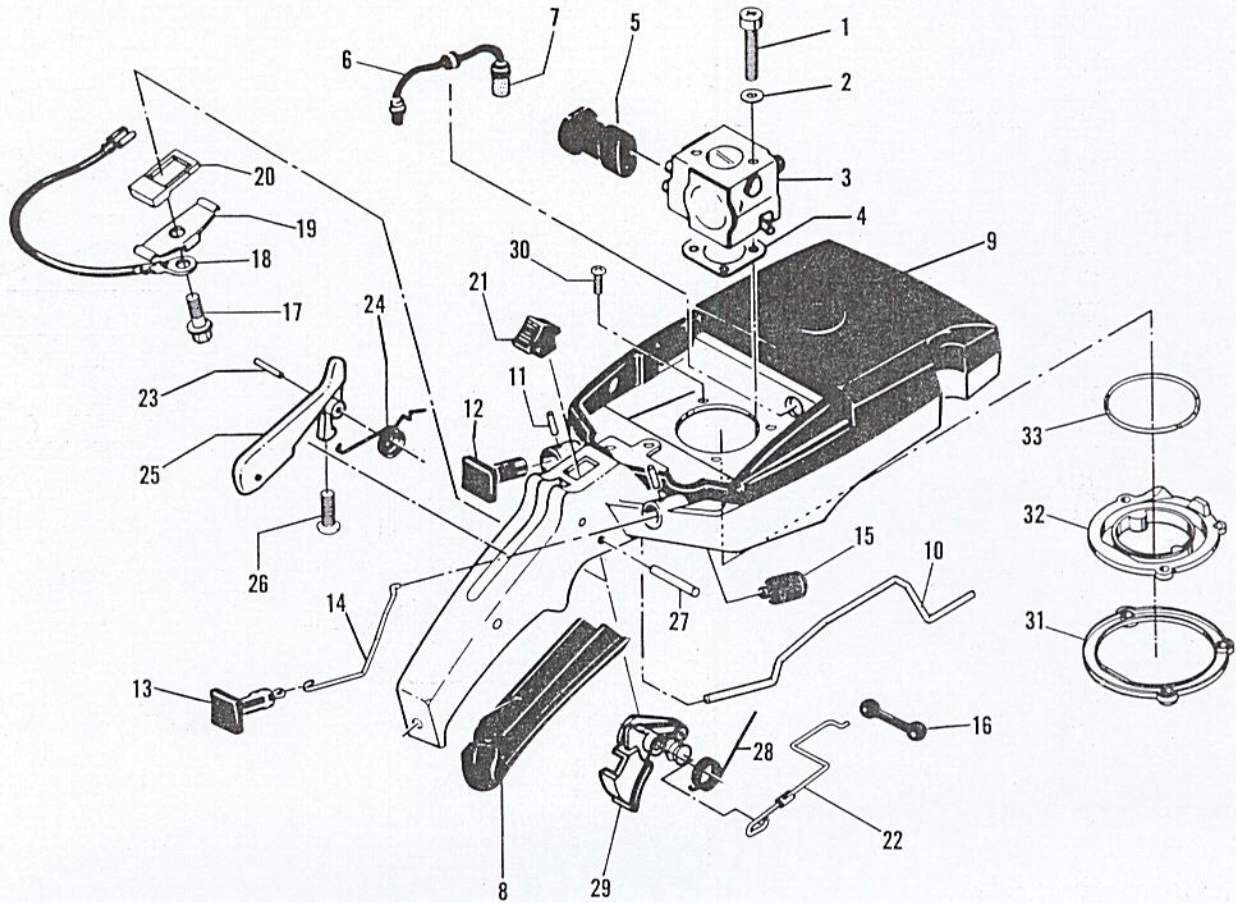

ITEM NO.	PART NUMBER	DESCRIPTION	UNITS PER ASY.
1	218701	Screw Skt hd 10-24 x 2 (35-40 in. lb. torque)	2
2	110964	Washer-Plain	2
3	Fig. 8	Carburetor Assembly	1
4	86189	Gasket-Carburetor	1
5	218610	Grommet-Mix Adj.	1
6	215708	Hose Assembly-Fuel	1
7	215714	. Pickup Assembly-Fuel	1
8	89320	Insert-Handle Grip	1
9	218620	Tank/Control Assembly	1
10	218603	. Rod-Oiler	1
11	105673	. Pin-Roll .099 x .562	2
12	95615	. Button-Oiler	1
13	95614	. Button-Choke	1
14	218604	. Rod-Choke	1
15	69597	. Boot-Control Rod	1
16	69043	. Snubber-Rod	1

ITEM NO.	PART NUMBER	DESCRIPTION	UNITS PER ASY.
17	110706	. Screw-Pn hd 8-18 x .50	1
18	83661	. Wire Assembly-Stop Switch	1
19	62451	. Contact-Swtich	1
20	214691	. Base-Switch	1
21	68846	. Button-Switch	1
22	218605	. Rod-Throttle	1
23	105654	. Pin-Roll .131 x .875	1
24	92154	. Spring-Trigger Release	1
25	94275	. Release Assembly-Trigger	1
26	111012	. . Screw-Pn hd 4-40 x .31	1
27	110378	. Pin-Roll .196 x .937	1
28	92152	. Spring-Trigger	1
29	218609	. Trigger Assembly-Throttle	1
30	215874	. Screw M4 x 9.5 Torx	3
31	218599	. Clamp Assembly-Boot	1
32	218600	. Boot-Fuel Tank	1
33	218601	. Ring-Boot	1



# CARBURETOR ASSEMBLY

Figure 8

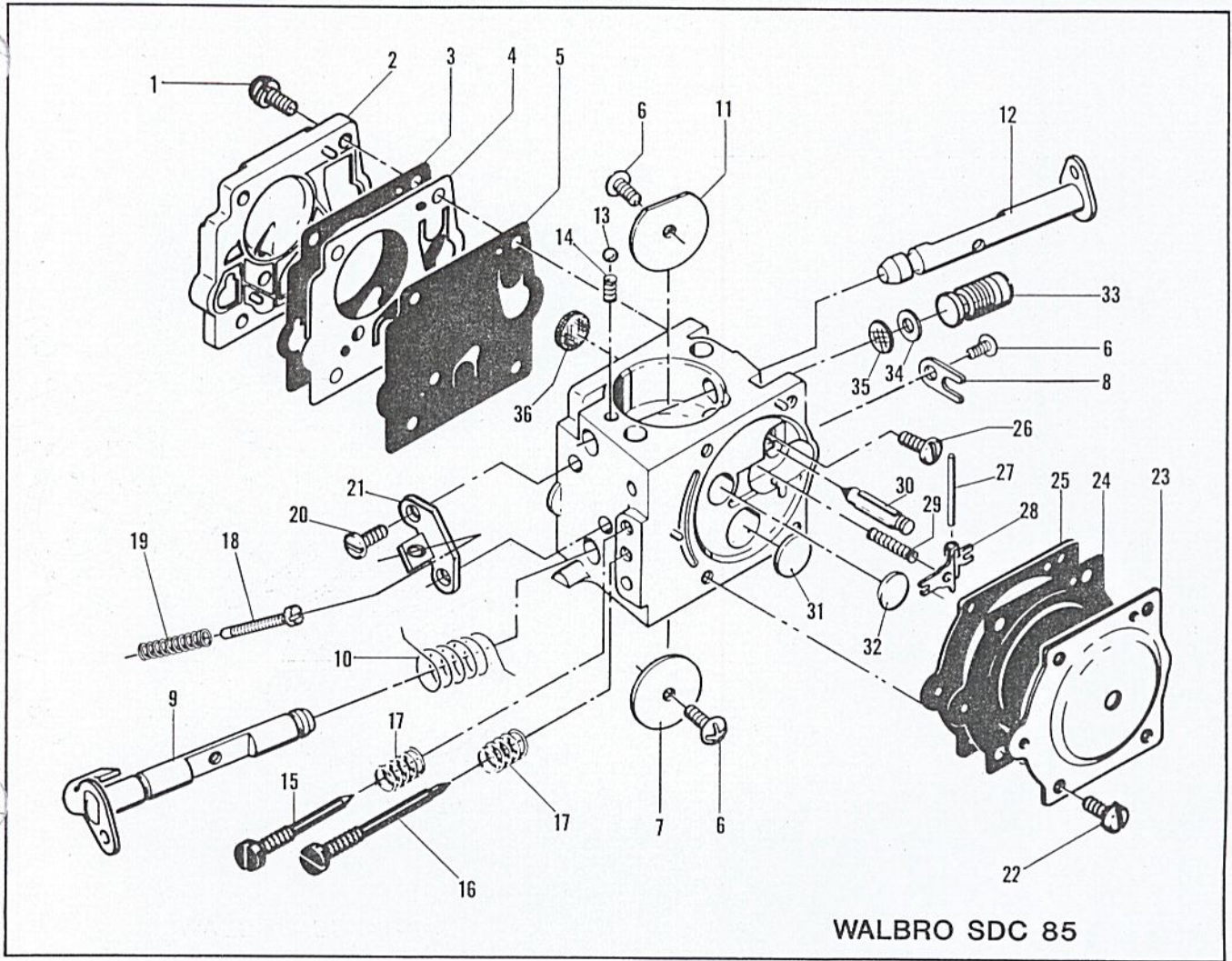

ITEM NO.	PART NUMBER	DESCRIPTION	UNITS PER ASY.
1	218616	Carburetor Assembly	1
2	--	.Screw - Pump Cover	4
3	--	.Cover - Pump	1
4	-- ① ②	.Gasket - Cover	1
5	-- ① ②	.Diaphragm - Check Valve	1
6	-- ①	.Diaphragm - Fuel Pump	1
7	--	.Screw - Plate	2
8	--	.Plate - Throttle	1
9	--	.Shaft Asy - Throttle	1
10	-- ①	.Spring - Throttle Shaft	1
11	--	.Plate - Choke	1
12	--	.Shaft Asy - Choke	1
13	-- ①	.Ball - Choke Friction	1
14	--	.Spring - Choke Friction	1
15	-- ①	.Needle - High Speed	1
16	--	.Needle - Low Speed	1
17	-- ①	.Spring - Needle	2
18	-- ①	.Screw - Idle Speed	1

ITEM NO.	PART NUMBER	DESCRIPTION	UNITS PER ASY.
19	--	.Spring - Idle Screw	1
20	--	.Screw - Idle Bracket	2
21	--	.Bracket - Idle	1
22	--	.Screw - Diaphragm Cover	4
23	--	.Cover - Diaphragm	1
24	-- ① ②	.Diaphragm - Metering	1
25	-- ① ②	.Gasket - Diaphragm	1
26	-- ①	.Screw - Lever Pin	1
27	-- ①	.Pin - Lever	1
28	-- ①	.Lever - Metering	1
29	-- ①	.Spring - Lever	1
30	-- ①	.Valve - Needle	1
31	-- ①	.Plug - 3/8"	1
32	-- ①	.Plug - 5/16"	1
33	--	.Valve & Seat Asy	1
34	--	.Washer - Check Valve	1
35	-- ①	.Screen - Check Valve	1
36	-- ①	.Screen - Fuel	1

① Contained in Repair Kit P/N 219247  
 ② Contained in Gasket/Diaphragm Kit P/N 219248



Figure 9 POWERHEAD & OILER

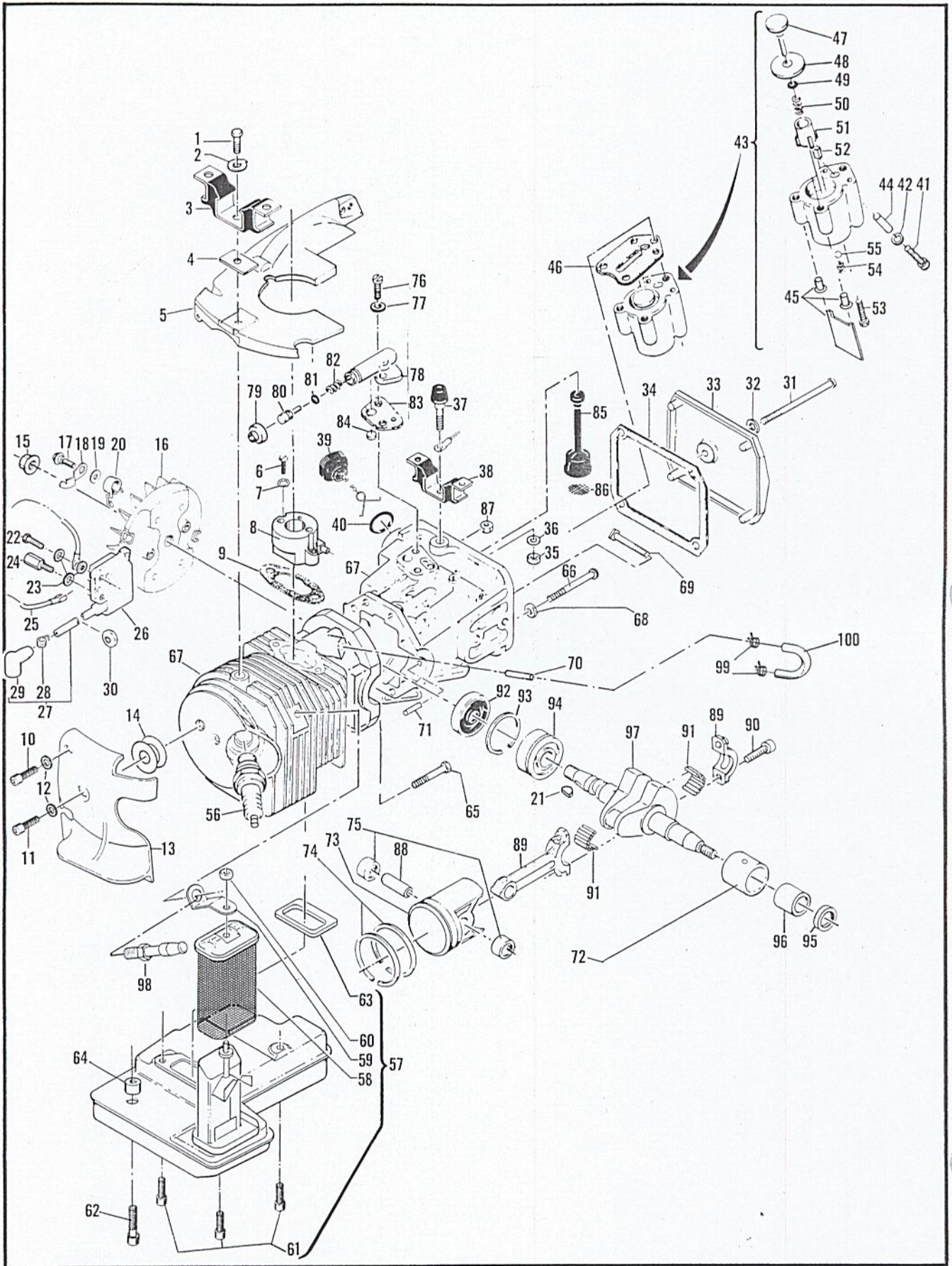



FIGURE 9 POWERHEAD &amp; OILER ASSEMBLIES

ITEM NO.	PART NUMBER	DESCRIPTION	UNITS PER ASY.	ITEM NO.	PART NUMBER	DESCRIPTION	UNITS PER ASY.
1	83811	Screw-Special (90-100 in. lb. torque)	1	51	62227	. Sleeve-Adjustment	1
2	69924	Lockplate	1	52	91259	. Pad-Oil Pump	1
3	93925	Mount-Rear	1	53	110386	. Screw-Hx hd 8-32 x 1	1
4	84619	Insulator	1	54	-- --	. Spring-Outlet Valve	1
5	218617	Shroud-Upper	1	55	-- --	. Ball-Outlet Valve	1
6	110713	Screw 10-24 x .88 (35-40 in. lb. torque)	2	56	63432	Spark Plug-Ac-C542T (120 in. lb. torque)	1
7	216635	Washer-Plain .203.I.D.	2	57	216160	Kit-Muffler	1
8	218708	Insulator-Inlet	1	58	214283	. Spark Screen & Cap Assembly	1
9	88740	Gasket-Insulator	1	59	216087	. Strap-Muffler	1
10	216670	Screw-Skt 10-24 x 1/2 (55-60 in. lb. torque)	1	60	216682	. Nut-Hex Lock 10-24	1
11	216669	Screw-Skt 10-24 x 3/4 (55-60 in. lb. torque)	1	61	104895	. Screw-Skt 10-24 x .62 (65-75 in. lb. torque)	3
12	216643	Washer-#10	2	62	110713	. Screw-Skt 10-24 x .88 (65-75 in. lb. torque)	1
13	218706	Shroud-Rear	1	63	95387	. Gasket-Muffler	1
14	93460	Washer-Insulator	1	64	216047	. Spacer	1
15	110703	Nut-Hex 3/8-24 (265-325 in. lb. torque)	1	65	110644	Screw-Hx hd 8-32 x 1.50 (35-40 in. lb. torque)	1
16	95481	Flywheel Assembly	1	66	62106	Screw-12-24 x 1.75 (70-75 in. lb. torque)	4
17	93464	. Screw-Pawl	2	67	① 215713	Kit-Cylinder-C'case, Piston	1
18	93198	. Pawl-Starter	2	68	111025	. Washer-Sealing	4
19	93469	. Washer-Pawl	2	69	92459	.Bolt-Bar	2
20	214102	. Spring-Pawl	2	70	69600	.Nipple-Pulse line	1
21	100106	Key-Woodruff	1	71	110851	.Pin-Dowel	1
22	110127	Screw-Hx hd 10-24 x .88 (SEMS) (55-60 in. lb. torque)	1	72	87152	.Insert-Bearing	1
23	100002	Washer-#10	3	73	① 92518	.Piston Assembly "A"	1
24	95603	Stud-Special (55-60 in. lb. torque)	1		① 92519	.Piston Assembly "B"	1
25	85798	Wire Assembly-Ground	1		① 92520	.Piston Assembly "C"	1
26	95553	Electronic Ignition Assembly	1	74	85414	..Ring Set-Piston	1
27	95269	. Wire Assembly-Spark Plug	1	75	111021	..Bearing-Needle	1
28	102556	. . Connector	1	76	110338	Screw-Hx Hd 8-32 x .532 (15-20 in. lb. torque)	2
29	95266	. . Boot	1	77	110613	Washer-No. 8 Hard	2
30	110995	Grommet	1	78	84156	Housing-Pump	1
31	110291	Screw-Skt 10-24 x 2-5/8 (35-50 in. lb. torque)	1	79	215151	Cap-Housing	1
32	110921	Washer-Sealing	1	80	92902	Plunger-Pump	1
33	218707	Cover-Oil Tank	1	81	105614	"O" Ring	1
34	86306	Gasket-Cover	1	82	66687	Spring-Pump	1
35	101143	Nut-Hx Lock 1/4-20	1	83	91669	Gasket-Pump	1
36	102523	Washer-1/4	1	84	91668	Valve-Pump	1
37	69832	Bumper-Front	1	85	91672	Hose-Oil	1
38	93926	Mount-Front	1	86	51506	.Screen-Hose	1
39	216052	Cap-Oil Tank	1	87	100955	Nut-Hx Lock 8-32	1
40	101148	"O" Ring	1	88	69020	Pin-Piston	1
41	110890	Screw-Fil 10-24 x .88 (25-30 in. lb. torque)	1	89	215245	Connecting Rod Assembly	1
42	100003	Washer-#10	1	90	61627-01	.Screw-Connecting Rod (65-70 in. torque)	2
43	215339	Pump Assembly-Pulse	1	91	215613	Roller (Set of 11)	2
44	91774	. Sleeve	1	92	61618	Seal-Oil	1
45	215246	. Kit-Oil Pump Clip	1	93	63464	Ring-Snap	1
46	92874	. . Seal-Pulse Pump	1	94	63429-02	Bearing-Ball	1
47	214278	. Piston Assembly-Pump	1	95	110260	Seal-Oil	1
48	86182	. Ring-Piston	1	96	104357	Bearing-Needle	1
49	105603	. "O" Ring	1	97	95386	Crankshaft	1
50	60259	. Spring - Piston	1	98	215673	Valve-Compression Release (110-120 in. lb. torque)	1
				99	218614	Clamp-Hose	2
				100	218602	Line-Pulse	1

① Piston/Cylinder/Crankcase Assemblies are furnished in matched sets and are identified by a letter "A", "B" or "C" stamped on both cylinder and piston. Order replacement pistons with the same letter that is stamped on the cylinder. For piston replacement in an unmarked cylinder, use Piston Assembly, P/N 92519, identified as "B".