

ILLUSTRATED PARTS LIST

MODELS	SERIAL NUMBER PREFIX	MODELS	SERIAL NUMBER PREFIX
600150-03	13-		
600150-04	13-		
600150-06	13-		

McCulloch Chain Saws are identified by a model number (in this instance 600150) followed by a suffix number (03, 04, etc.). Suffix numbers denote variations in parts or assemblies used in the manufacture of this product.

Part numbers listed in this I.P.L. which have a circled number ① or numbers preceding the description, are used only on the model or models identified by a circled number ① or numbers.

Part numbers which have one or more dots (.) preceding their descriptions may be ordered individually, but they are also included in the kit or assembly whose description begins directly above the dot(s).

The policy of McCulloch Corporation is one of continual improvement in design, manufacturing and engineering advancement wherever possible to assure still finer power tools. Hence, specifications, equipment, colors, design and manufacturer's suggested list prices are subject to change without notice and McCulloch Corporation reserves the right to make such changes without prior notification or obligation to backfit or supply backfit components for units previously shipped from the factory.

Double Eagle™ 50 CHAIN SAW

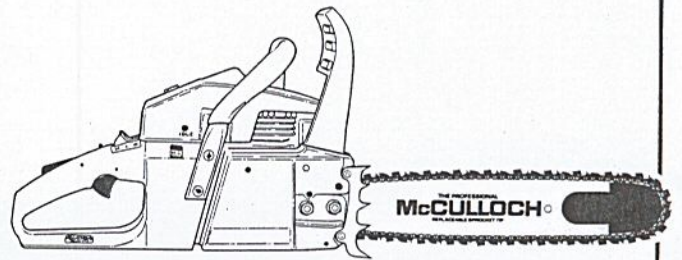

- CONTENTS -

	PAGE
FIGURE 1. General Assembly	2
FIGURE 2. Starter Assembly	3
FIGURE 3. Chain Brake Asy	4
FIGURE 4. Carburetor Asy	5
FIGURE 5. Powerhead Asy	6
FIGURE 6. Engine Specifications	7
FIGURE 7. Bar/Chain/Sprocket	7
FIGURE 8. Main Frame Asy	8

OCTOBER 1987

To answer service-related questions and to solve common consumer problems quickly, call this toll-free hot-line:

(800) 423-6302

If located in Arizona, call collect:
(602) 453-3681



McCULLOCH
CORPORATION

© U.S.A. - McCulloch Corporation, 1987

Printed in U.S.A.

222411

900 Lake Havasu Avenue, Lake Havasu City, Arizona 86403

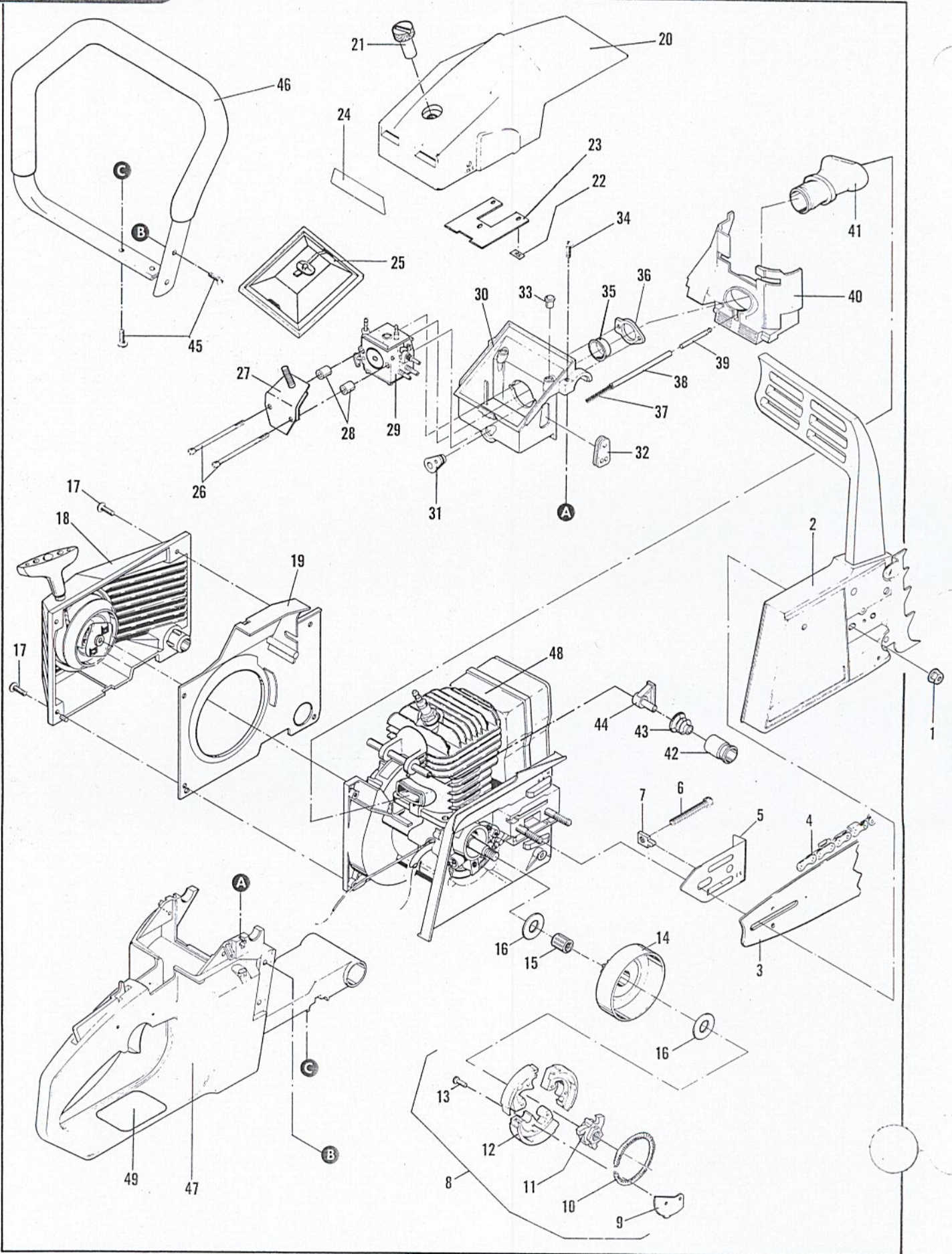

ITEM NO.	PART NUMBER	DESCRIPTION	UNITS PER ASY.
1	218042	Nut-Flange M8	2
2	Fig. 3	Brake Asy-Chain	1
3	Fig. 7	Bar	1
4	Fig. 7	Chain	1
5	217594	Plate-Bar	1
6	217640	Screw-Bar Adjustment	1
7	217479	Nut-Bar Adjustment	1
8	219854	Clutch Asy (3 Shoe)	1
9	-- --	. Plate-Shoe	3
10	-- --	. Spring Asy-Clutch	1
11	-- --	. Rotor-Clutch	1
12	-- --	. Shoe-Clutch	3
13	-- --	. Rivet	6
14	Fig. 7	Drum/Spkt/Bearing Asy	1
15	110971	. Bearing-Needle	1
16	86958	. Shim	2
17	217936	Screw-10-24x.75 (50 in. lb. torque)	4
18	Fig. 2	Starter Assembly	1
19	218840	Baffle-Fan	1
20	222217	Cover Asy-Air	1
21	222206	. Knob	1
22	-- --	. Nut-Press	3
23	-- --	. Plate	1
24	218257-01	Decal-Instruction	1
25	219071	Filter-Air	1
26	219231	Screw-10-24x2.19	2
27	219103	Shield-Spitback	1

ITEM NO.	PART NUMBER	DESCRIPTION	UNITS PER ASY.
28	218757	Spacer-Shield	2
29	Fig. 4	Carburetor	1
30	218723	Box-Air	1
31	218761	Grommet-Throttle/Choke	1
32	91995-01	Grommet-Carburetor Needles	1
33	218922	Bushing-Hose	2
34	217937	Screw-10-24x1 (20 in. lb. torque)	2
35	218809	Eyelet	1
36	218792	Flange-Carburetor Mount	1
37	93998	Spring-Pulse Hose	1
38	218972	Hose-Pulse	1
39	218129	Barb-Pulse Hose	1
40	218768	Shroud-Cylinder	1
41	218780	Boot-Intake	1
42	218371	Carrier-Rear Mount	2
43	218801	Mount-Rear	2
44	218362	Retainer-Rear Mount	2
45	217936	Screw-10-24x.75 Torx (50 in. lb. torque)	4
46	218787	Frame-C	1
47	Fig. 8	Main Frame Assembly	1
48	Fig. 5	Powerhead Assembly	1
49	219058	Label-Safety	1

STARTER ASSEMBLY **Figure 2**

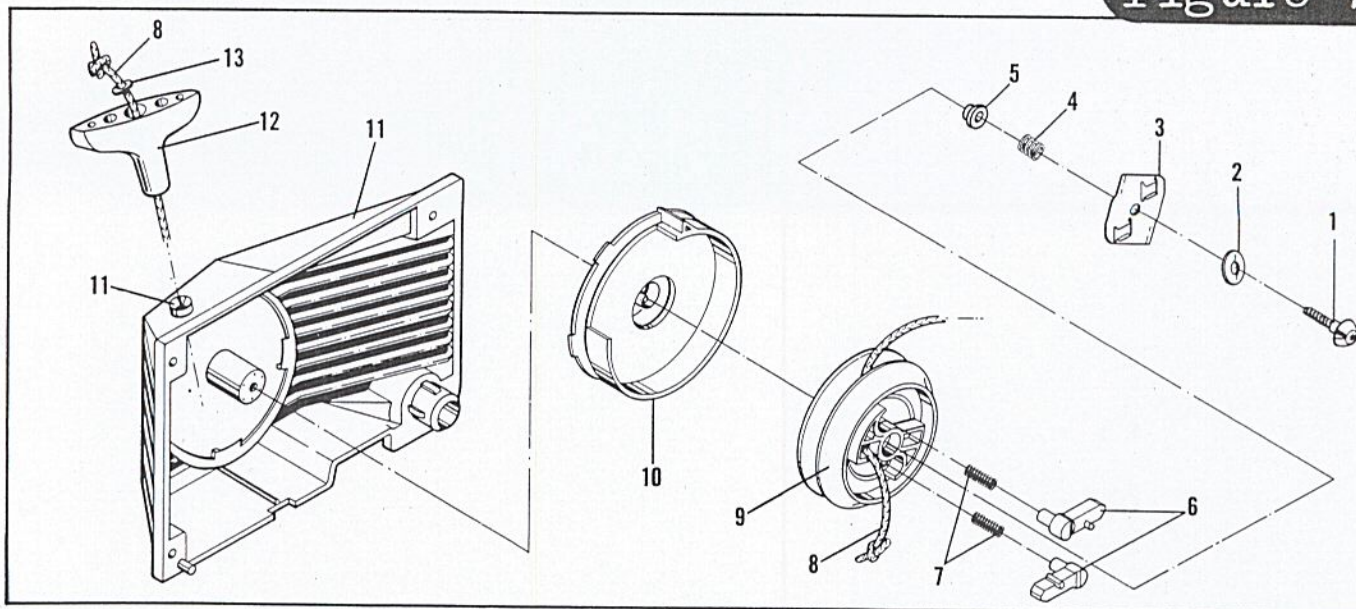

ITEM	PART NUMBER	DESCRIPTION	UNITS PER ASY.
	216044	Starter Assembly	1
1	218056	. Screw-Pawl Plate	1
2	218055	. Washer-Pawl Plate	1
3	217893	. Plate-Pawl	1
4	218054	. Spring-Pawl Plate	1
5	218053	. Bushing-Pulley	1
6	217890	. Pawl	2

ITEM NO.	PART NUMBER	DESCRIPTION	UNITS PER ASY.
7	218052	. Spring-Pawl	2
8	218051	. Rope	1
9	217889	. Pulley-Starter	1
10	217891	. Spring/Housing Assembly	1
11	218929	. Housing/Guide Assembly	1
12	91255	Handle-Starter	1
13	105490	. Washer	1

Figure 3 CHAIN BRAKE ASSEMBLY

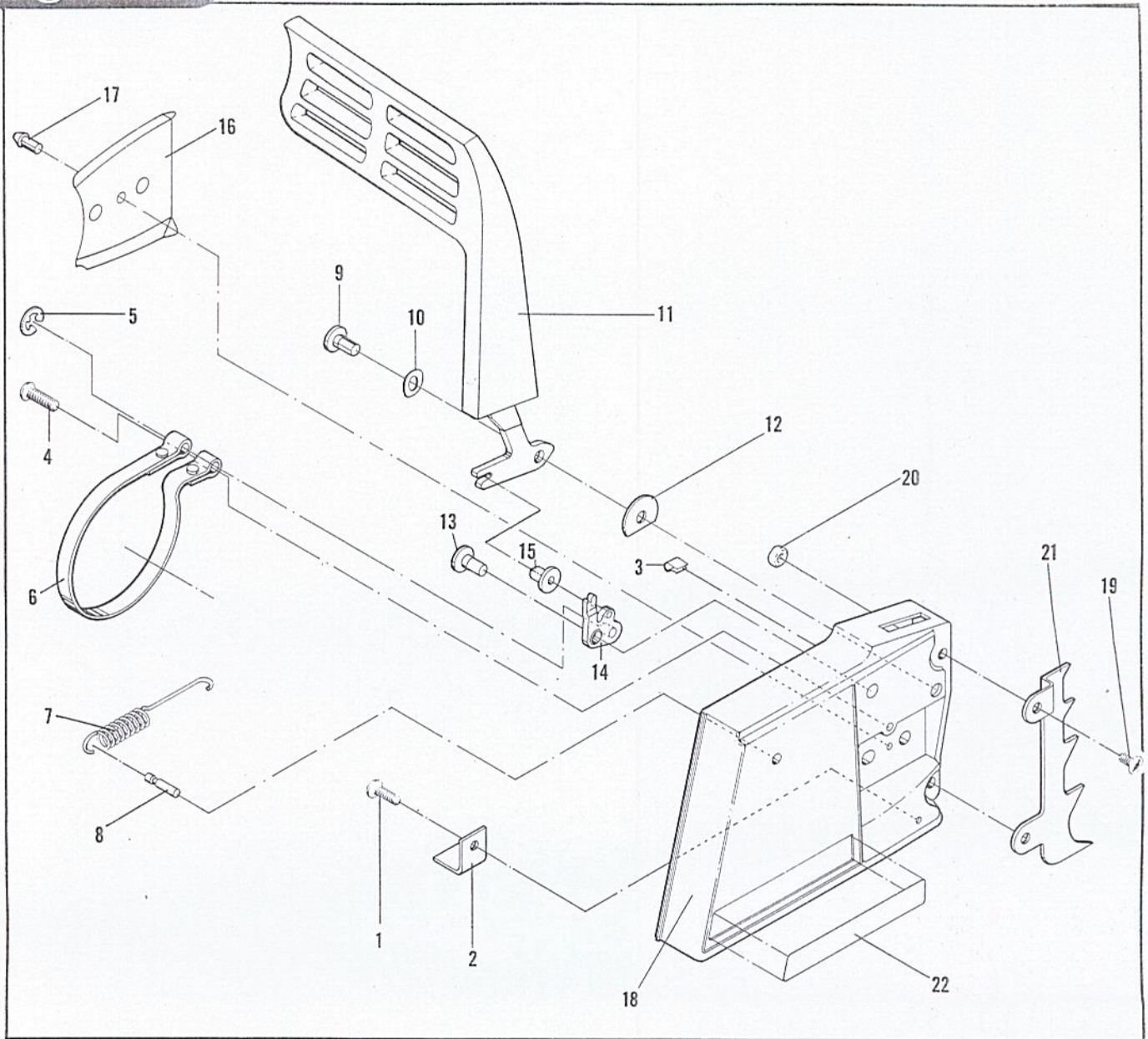

CHAIN BRAKE

ITEM NO.	PART NUMBER	DESCRIPTION	UNITS PER ASY.	ITEM NO.	PART NUMBER	DESCRIPTION	UNITS PER ASY.
1	218407 219195	Chain Brake Assembly . Screw-10-24x.50 (45-50 in. lb. torque)	1 1	11	218059	. Flag Lever Assembly	1
2	218641	. Stop-Chain	1	12	218674	. Washer	1
3	110737	. Clip	1	13	217448	. Pivot-Latch	1
4	218361	. Screw-1/4-20x.75 (85-90 in. lb. torque)	1	14	217454	. Latch Assembly	1
5	218079	. E-Clip-Brake Band	1	15	218956	. Slider-Latch	1
6	217472	. Brake Band	1	16	218832	. Plate-Bar	1
7	217440	. Spring-Chain Brake	1	17	218719	. Screw-Drive	1
8	217449	. Pin-Spring Hook	1	18	217664	. Chain Brake Housing	1
9	217450	. Pivot-Lever	1	19	217935	Screw-10-24x.50 (45-50 in. lb. torque)	2
10	218679	. Washer-Spring	1	20	218315	Nut-Hex 10-24	2
				21	218103	Spike	1
				22	218728	Plate-Name	1

CARBURETOR ASSEMBLY

Figure 4

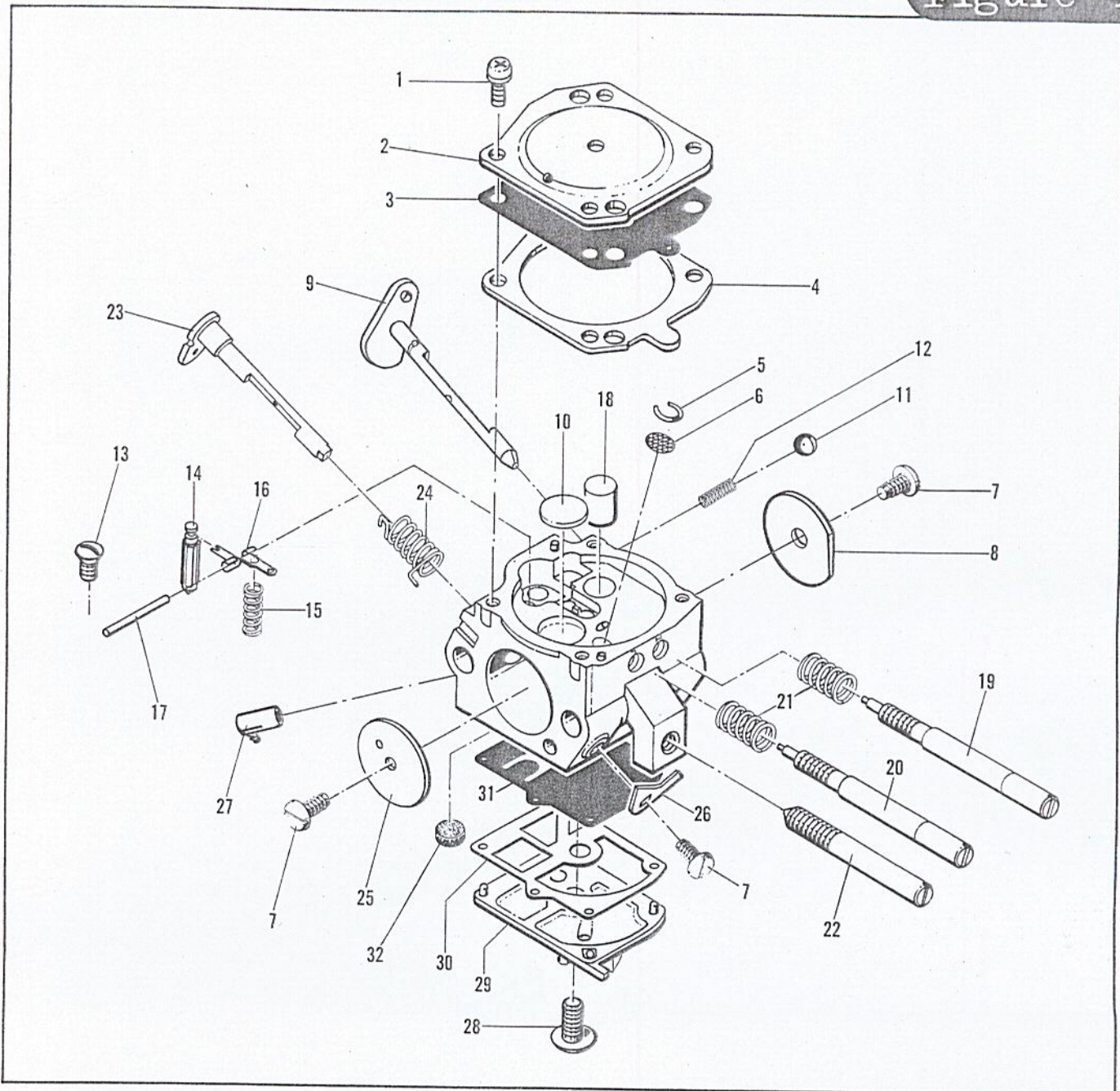

ITEM NO.	PART NUMBER	DESCRIPTION	UNITS PER ASY.
	218783	Walbro HDA-36	
1	-- -- ①	.Screw-Metering Cover	4
2	-- --	.Cover-Metering Diaphragm	1
3	-- -- ①②	.Diaphragm Asy-Metering	1
4	-- -- ①②	.Gasket-Metering Diaphragm	1
5	-- -- ①	.Ring-Screen Retainer	1
6	-- -- ①	.Screen-Check Valve	1
7	-- -- ①	.Screw	3
8	-- --	.Shutter-Choke	1
	-- --	.Shaft/Lever Asy Choke	1
	-- -- ①	.Plug-Welch	1
	-- -- ①	.Ball-Choke Friction	1
12	-- -- ①	.Spring-Choke Friction	1
13	-- -- ①	.Screw-Metering Lever Pin	1
14	-- -- ①	.Valve-Inlet Needle	1
15	-- -- ①	.Spring-Metering Lever	1
16	-- -- ①	.Lever-Metering	1

ITEM NO.	PART NUMBER	DESCRIPTION	UNITS PER ASY.
17	-- -- ①	.Pin-Metering Lever	1
18	-- --	.Nozzle Asy/Check Valve	1
19	-- -- ①	.Needle-High Speed	1
20	-- -- ①	.Needle-Low Speed	1
21	-- -- ①	.Spring-High/Low Speed Needle	2
22	-- --	.Screw-Idle Adjustment	1
23	-- --	.Shaft/Lever Asy-Throttle	1
24	-- -- ①	.Spring-Throttle Return	1
25	-- --	.Shutter-Throttle	1
26	-- --	.Stop-Throttle	1
27	-- --	.Fitting-Elbow	1
28	-- --	.Screw-Pump Cover	1
29	-- --	.Cover-Fuel Pump	1
30	-- -- ①②	.Gasket-Fuel Pump	1
31	-- -- ①②	.Diaphragm-Fuel Pump	1
32	-- -- ①	.Screen-Fuel Inlet	1

① Contained in Major Repair Kit P/N 219074
 ② Contained in Minor Repair Kit P/N 219075

NOTE: Only those parts listed in repair kits are available for service replacement.

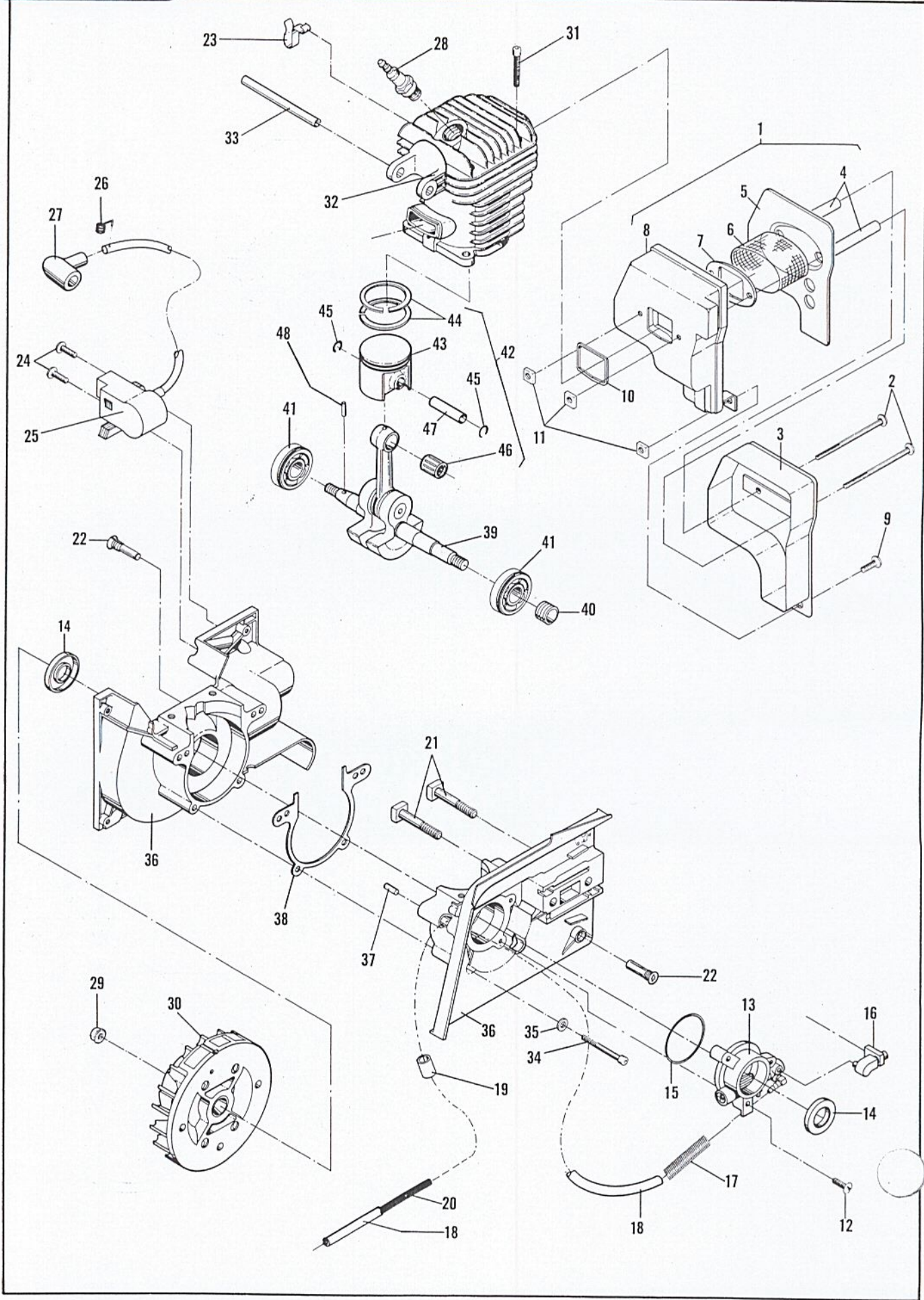

FIGURE 5 POWERHEAD ASSEMBLY

ITEM NO.	PART NUMBER	DESCRIPTION	UNITS PER ASY.	ITEM NO.	PART NUMBER	DESCRIPTION	UNITS PER ASY.
1	218793	Muffler Assembly	1	25	218830	Ignition Assembly	1
2	217942	. Screw-10-24x2.62 (70 in. lb. torque)	2	26	102556	. Connector-Spark Plug	1
3	218795	. Muffler Body-Outer	1	27	95266	. Boot-Spark Plug	1
4	218030	. Tube-Bolt	2	28	62345	Spark Plug	1
5	218725	. Baffle	1	29	218042	Nut-Flywheel (220-250 in. lb. torque)	1
6	217629	. Screen-Spark Arrester	1	30	218635	Flywheel Assembly	1
7	217627	. Plate-Reinforcement	1	31	217943	Screw 1/4-20x1.0 (90 in. lb. torque)	4
8	218794	. Body-Inner	1	32	218781	Cylinder Assembly	1
9	217935	Screw-10-24x.50 (70 in. lb. torque)	1	33	218149	. Pin-Roll	1
10	215947	Gasket-Exhaust	1	34	217721	Screw-10-24x1.625 (70 in. lb. torque)	4
11	218005	Nut-Muffler 10-24	3	35	216591	Washer-Flat	4
12	217936	Screw-10-24x.75 (30 in. lb. torque)	3	36	216477	Crankcase Assembly	1
13	222419 ①	Oiler Assembly	1	37	215834	. Dowel Pin-Crankcase	2
14	215892 ①	. Seal-Oil	2	38	216508	Gasket-Crankcase	1
15	217867	. Ring-"0"	1	39	218897	C' Shaft/C-Rod/Wormgear	1
16	219972	Connector-Oil Pump	1	40	217273	. Wormgear	1
17	218669	Guard-Oil Hose	1	41	215946	. Bearing-Ball	2
18	218482	Hose-Oil Pump	1	42	218952	Piston Assembly	1
19	219051	Sleeve-Oil Hose	1	43	218751	. Piston	1
20	218589	Spring-Oil Hose	1	44	215825	. Ring-Piston	2
21	92459	Bolt-Bar	2	45	215876	. Ring-Snap	2
22	217781	Screw-Front Mount (50 in. lb. torque)	2	46	215837	. Bearing-Piston Pin	1
23	218865	Clip-Spring	1	47	215836	. Pin-Piston	1
24	217936	Screw-10-24x.75 (35-45 in. lb. torque)	2	48	217632	Pin-Timing	1

① Although 2 seals are required for the unit, only 1 seal is included with the Oiler Assembly.

SPECIFICATIONS **Figure 6**

Displacement 50cc - 3.1 Cu. In.	Auto Oiler Type Gear Driven
Bore & Stroke (inches) 1.72 x 1.26	Clutch Engagement Speed 2900 - 3350 RPM
Cylinder Hard Chrome Plated	Idle Speed 2200 - 2500 RPM
Bearing:	Ignition Electronic
Main Ball	Lamination/Flywheel Airgap .. .010 - .012
Connecting Rod Needle	Spark Plug/Gap Champion DJ8J/.025
Fuel Tank Capacity 20 Ounces	Weight (PUO)
Oil Tank Capacity 7.5 Ounces	Carburetor Adjustment Two Needle/External

BAR / CHAIN / SPROCKET **Figure 7**

NOTE
Before ordering replacement service parts, identify pitch of Sprocket/Drum/Bearing Assembly supplied with your unit (see Sprocket Identification chart). Order only components of the same pitch to ensure proper mesh.

FOR .375 PITCH

FOR .325 PITCH

218928	Sprocket/Drum/Bearing Asy.	218925	Sprocket/Drum/Bearing Asy.
94074-00	16" Speed Mac Bar	218923	16" Sprocket Tip Bar
86830	Replacement - Sprocket Tip	218999	Replacement - Sprocket Tip
218839-12	16" Chain PMR 370GLX 60 CL	218551-12	16" Chain SPG 320GLX 68 CL
94074-05	16" Speed Mac Bar	218924	20" Sprocket Tip Bar
219975	Replacement - Sprocket Tip	218999	Replacement - Sprocket Tip
218839-12	16" Chain PMR 370GLX 60 CL	218552-12	20" Chain SPG 320GLX 79 CL
93778-00	20" Speed Mac Bar	SPROCKET IDENTIFICATION	
86830	Replacement - Sprocket Tip		
218069-12	20" Chain PMR 370GLX 70 CL		
93778-05	20" Speed Mac Bar		
219975	Replacement - Sprocket Tip		
218069-12	20" Chain PMR 370GLX 70 CL		

NOTE: Part number of Guide Bar is stamped on the bar.

Figure 8 MAIN FRAME ASSEMBLY

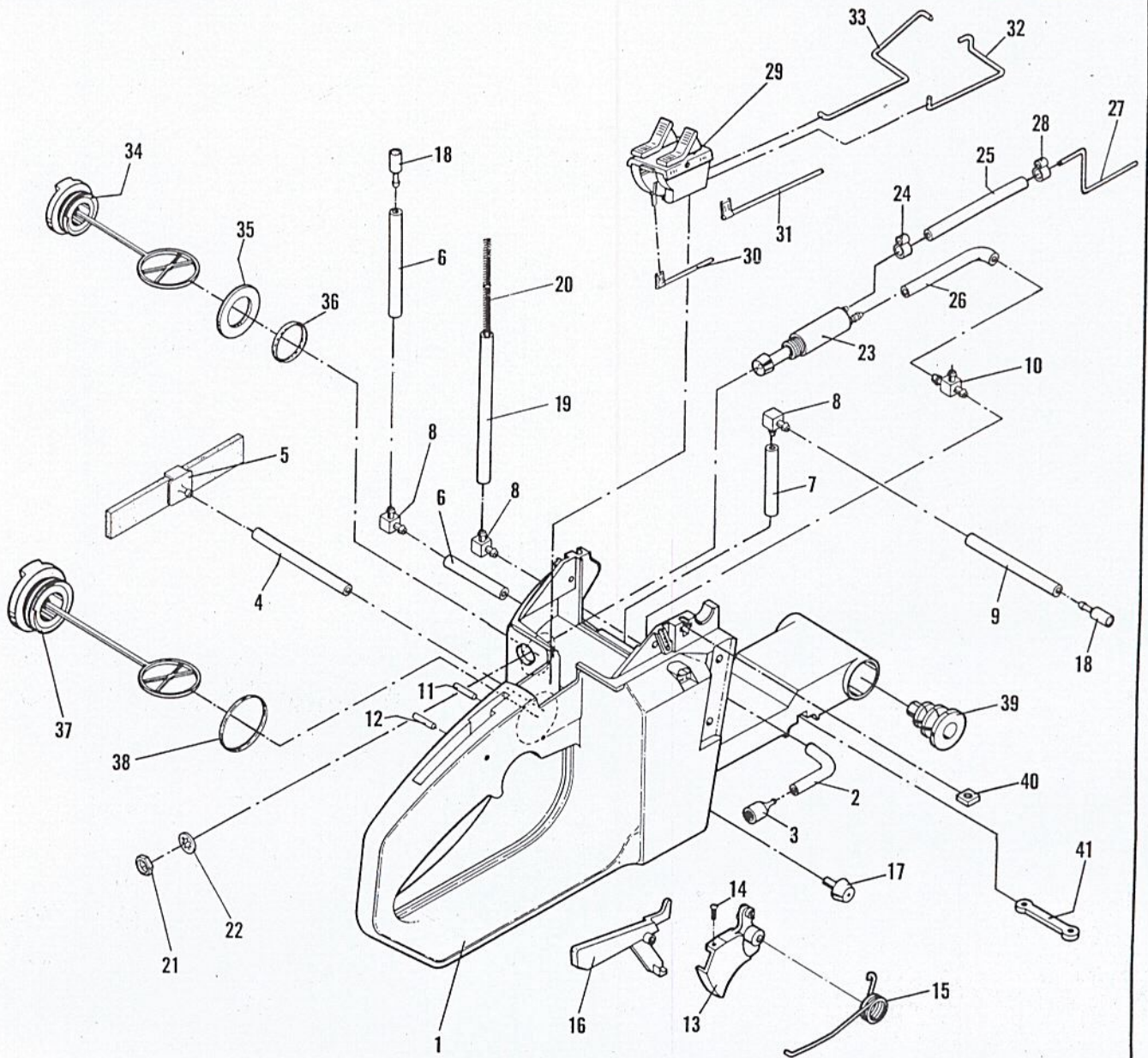

ITEM NO.	PART NUMBER	DESCRIPTION	UNITS PER ASY.	ITEM NO.	PART NUMBER	DESCRIPTION	UNITS PER ASY.
1	222420	Mainframe Assembly	1	21	219917	Nut-Hex	1
	219988	. Mainframe-Weldment	1	22	219918	Washer-Lock	1
2	218535	. Hose-Oil Pickup	1	23	219945	Oiler-Manual Assembly	1
3	92465	. Pickup-Oil	1	24	219915	. Clamp	1
4	218535	. Hose-Fuel Tank	1	25	219911	. Hose-Oil Outlet	1
5	218895	. Pickup Asy-Fuel	1	26	219912	. Hose-Oil Inlet	1
6	219059	. Hose-Vent (Fuel)	2	27	219913	Tube-Oil Outlet	1
7	219967	. Hose-Barb (Oil)	1	28	219915	Clamp	1
8	218896	. Barb-Hose (Right Angle)	3	29	218786	Control Asy	1
9	219966	. Hose-Vent (Oil)	1	30	218348	Wire Asy-Ground	1
10	219914	. Barb-"T"	1	31	218349	Wire Asy-Switch	1
11	218491	. Pin-Trigger	1	32	218736	Rod-Choke	1
12	218492	. Pin-Trigger Release	1	33	218724	Rod-Throttle	1
13	93538-01	. Trigger Assembly	1	34	219999	Cap Asy-Oil (non-vented)	1
14	111013	.. Screw-5-40x.50	1	35	219943	. Gasket	1
15	93771	. Spring-Trigger	1	36	235511	. Ring-"O"	1
16	218836	. Release-Trigger	1	37	236790	Cap Asy-Fuel	1
17	218122	. Bumper-Cut Control	2	38	-- --	. Ring-"O"	1
18	218260	Vent-Fuel/Oil	2	39	218124	Mount-Front	2
19	218972	Hose-Fuel	1	40	218005	Nut-Square 10-24	2
20	93998	Spring-Fuel Hose	1	41	218117	Plate-Nut	1