

ILLUSTRATED PARTS LIST

MODEL NAMES	SERIAL NUMBER PREFIX	MODELS
PRO MAC 8200	13-	600072-06

PRO MAC 8200 CHAIN SAW

McCulloch products are identified by a model number (in this instance 600072) followed by a suffix number (00 or 06). Suffix numbers denote variations in parts or assemblies used in the manufacture of this product.

Illustrated Parts Lists (IPLs) contain a PART NUMBER, DESCRIPTION, UNITS per assembly and STOCKING CODE for each part. Stocking Codes are:

- A - Dealer Stocked. Fast to medium moving part.
- B - Distributor Stocked. Medium to slow moving part
- C - Factory Stocked. Slow moving part.
- T - McCulloch service tool.
- N - No longer available.
- R - Replaced Part.

NOTE: The following explains symbols/footnotes in this IPL.

(-) A dash preceding a PART NUMBER indicates that it is a new part number, different from the one listed in the previous IPL for this unit.

(.) One or more dots (. Spring-Starter) preceding a part DESCRIPTION indicates the part is included in the kit or assembly described directly above the dot(s).

(- - -) If four dashes appear in place of a PART NUMBER, the part is not available individually but is included in the next higher assembly or subassembly.

① ② Circled numbers preceding a DESCRIPTION footnote the part or assembly to additional information on the page.

(*) An asterisk draws attention to general information.

The policy of McCulloch Corporation is one of continual improvement in design, manufacturing and engineering advancement wherever possible to assure still finer power tools. Hence, specifications, equipment, colors, design and manufacturer's suggested list prices are subject to change without notice. McCulloch Corporation reserves the right to make such changes without prior notification or obligation to backfit or supply backfit components for units previously shipped from the factory.

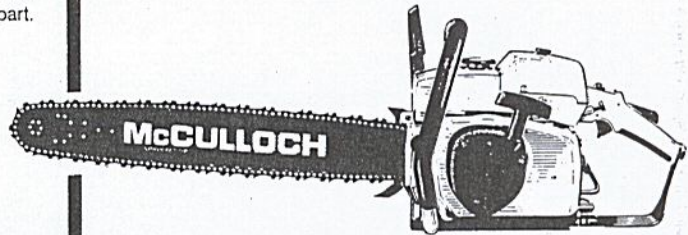

CONTENTS

	PAGE
FIGURE 1 General Assembly	2
FIGURE 2 Guide Bar / Sprocket Tip Replacement Guide	3
FIGURE 3 Powerhead and Oiler Assemblies	4
FIGURE 4 Fuel Tank Assembly	6
FIGURE 5 Chain Brake Assembly	7
FIGURE 6 Fan Housing and Starter Assembly	8
FIGURE 7 Carburetor Assembly	9
FIGURE 8 Specifications	10



**McCULLOCH
CORPORATION**

AUGUST 1992

215710-02

P.O. Box 11990 • Tucson, Arizona 85734

© U.S.A. - McCulloch Corporation, 1991 • Printed in U.S.A.

THIS IPL SUPERSEDES AND REPLACES 215710-01

FIGURE 1 GENERAL ASSEMBLY

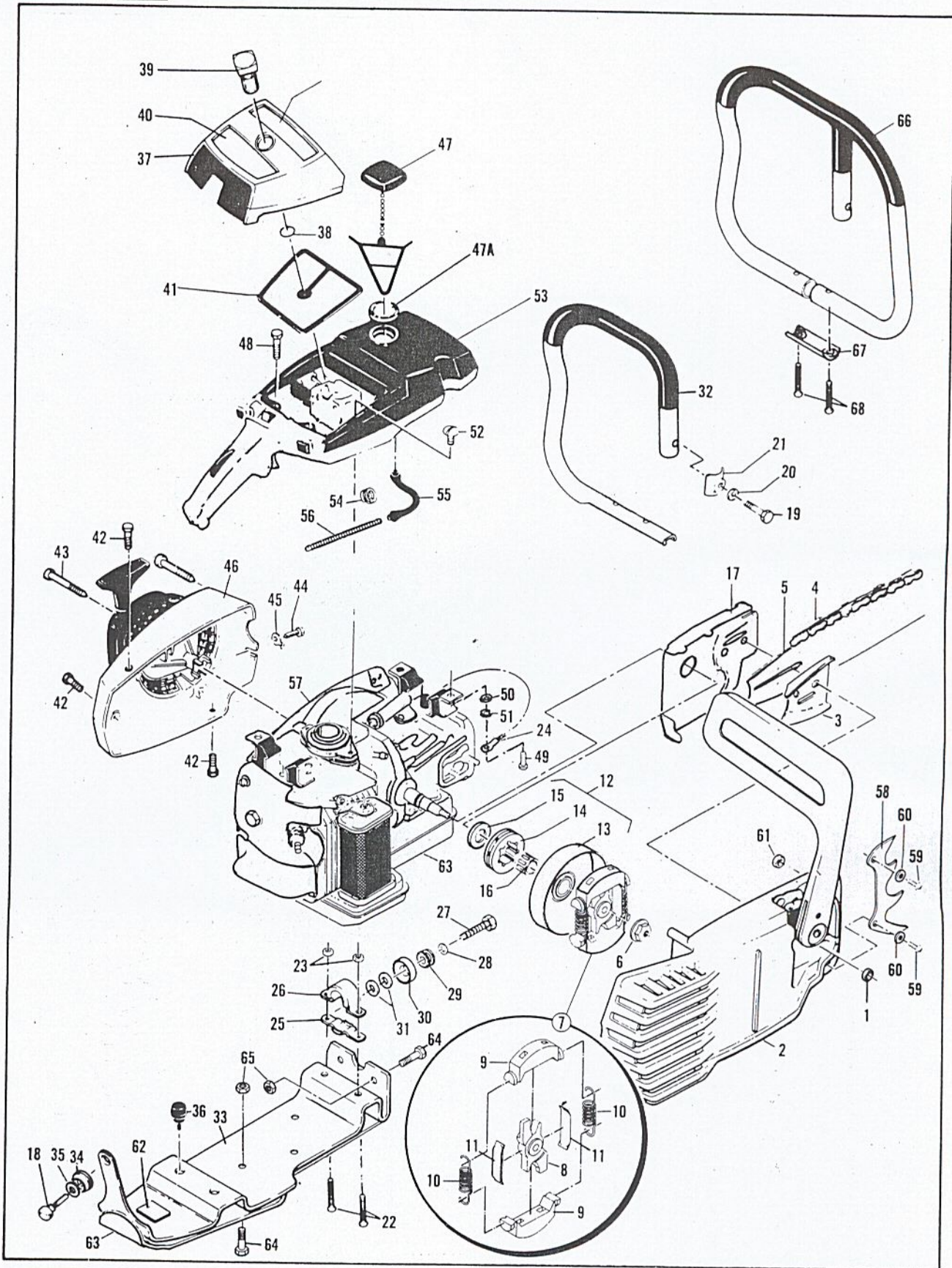

FIGURE 1 GENERAL ASSEMBLY

ITEM NO.	STK. CODE	PART NUMBER	DESCRIPTION	UNITS PER ASY.
1	A	213169	Nut, Hex Flange	2
2		Figure 5	Chain Brake Assembly	
3	A	64325	Plate, Bar Guide	1
4		---	① Chain Assembly	1
5		Figure 2	Bar Assembly	1
6	B	223060	Nut-Hex (L.H.) (160-170 in. lbs.torque)	1
7	A	214301	Clutch Assembly	1
8	A	214300	. Rotor, Clutch	1
9	B	67233	. Clutch Shoe	2
10	A	83223	. Spring, Clutch	2
11	B	64583	. Retainer, Clutch Spring	2
12	A	95166	Kit, Drum Sprocket Assembly (7 Tooth .375 pitch)	1
13	C	86947	. Drum/Hub Assembly	1
14	A	86145	. Sprocket-7 T .375 pitch	1
15	A	86958	. Washer, Shim	1
16	A	110971	Bearing, Needle	1
17	B	84978-01	Shield, Sawdust	1
18	C	213055	Screw, BTN 10-24x1.50 S (55-60 in. lbs. torque)	1
19	A	216638	Screw, Hex 1/4-20x1.50 (90-100 in. lbs torque)	1
20	A	100153	Washer, Lock	1
21	A	216639	Clamp, Frame	1
22	B	104395	Screw, PN 10-24x5/8	2
23	A	216682	Nut, Hex Lock 10-24x5/8	2
24	C	83828-01	Strap, Ground	1
25	C	92701	Clamp, Bottom, Lower MT	1
26	C	93932	Clamp, Lower MT	1
27	C	216648	Screw, Hex 1/4-20x2 (90-100 in. lbs. torque)	1
28	B	216647	Washer, Plain	1
29	B	84661	Grommet	1
30	A	85898	Mount, Lower	1
31	B	95636	Washer	2
32	B	214103	Frame and Grip Assembly	1
33	B	216090	Brace, Frame	1
34	B	93032	Grommet, Frame Brace	1
35	B	214764	Washer	1
36	B	89403	Bumper, Lower	2

ITEM NO.	STK. CODE	PART NUMBER	DESCRIPTION	UNITS PER ASY.
37	C	95418	Cover Assembly, Air Cleaner	1
38	B	110565	. Ring, Retaining	1
39	C	95420	. Knob, Cover	1
40	C	211305	Instruction Label	1
41	A	215681	Filter, Air	1
42	A	217936	Screw-TR 10-24x.75 TOR (55-60 in. lbs. torque)	3
43	A	216624	Screw, OV SKT 8-32x2.36 (35-40 in. lbs. torque)	3
44	B	102762	Screw, Hex 10-24x.50 (40-45 in. lbs. torque)	1
45	C	69890	Plate, Lock	1
46		Figure 6	Fan Housing/Starter Asy.	3
47	A	216053	Cap Assembly, Fuel	1
47A	A	69767	. Gasket	1
48	A	110746	Screw, Hex 10-24x.50 (55-60 in. lbs. torque)	2
49	C	216644	Screw, Hex 1/4-20x5/8	2
50	A	100153	Washer, Lock	2
51	B	216646	Washer, 1/4 Plain	2
52	C	110807	Screw, PN 8/32x5/16 (15-20 in. lbs. torque)	2
53		Figure 4	Fuel Tank Assembly	
54	C	87826	Clamp, Pulse Line	2
55	A	69598	Line, Pulse	2
56	B	67944	Spring, Hose Stiffener	1
57		Figure 3	Powerhead Assembly	
58	A	93668	Spike	1
59	A	102388	Screw, Hex 10-24x.625 (50-60 in. lbs. torque)	2
60	A	216683	Washer, Special 10	2
61	A	216682	Nut, Hex Lock 10-24 (55-60in. lbs. torque)	2
62	B	219058	Label, Safety	1
63	B	300715	Kit, Shield Frame	
64	A	216634	. Screw, PN 10-24 x .50	5
65	A	216649	. Nut, Hex Lock 10-24 NC-2B	5
66	B	300708	Kit, Full Wrap Handle	
67	C	95679	. Clamp-Frame BTM	1
68	C	103353	. Screw-HX 10-24 x 1.5	2

GUIDE BAR/SPROCKET TIP/SAW CHAIN REPLACEMENT **FIGURE 2**

Bar Description	Bar Part Number	Replacement Nose Description	Nose Part Number
16" Mac 10 .375	89502	*	---
16" Speed Mac .375	94074	Nose Assembly Bar .375	86830
16" Speed Mac .375	94074-05	Kit Sprocket Nose Assembly	223183
16" Speed Mac .325	223195	.325 Pitch Nose Assembly	223183
20" Mac 10 .375	89503	*	---
20" Speed Mac .375	93778	Nose Assembly Bar .375	86830
20" Speed Mac .375	93778-05	Kit, Sprocket Nose Assembly	219807
20" Speed Mac .325	218924	.325 Pitch Nose Assembly	218999
24" Mac 10 .375	89504	*	---
24" Speed Mac.375	86846	Nose Asy Bar .375	86830
24" Speed Mac.375	86846-05	Kit Spkt Nose Asy	219807
28" Mac 10 .375	89505	*	---
28" Speed Mac .375	86847	Nose Asy Bar .375	86830
28" Speed Mac .375	86847-05	Kit Spkt Nose Asy	219807
3" Speed Mac .375	91284-00	Kit Spkt Nose Asy	86830
33" Speed Mac .375	91284-01	Kit, Spkt Nose Asy	219807

Chain Description	Chain Part Number	File Plate Part Number	File Part Number	File Size
16" PMR 370 GLX 60 CL	218839-12			
16" PM 370 GX 60 CL	88167-12	219132	219161	7/32
16" SPR 320 GX 60 CL	89974-12			
16" SPG 320 GLX 68 CL	218551-12	219130	98023	11/64
20" SPR 370 GX 70 CL	89978-12			
20" SPR GX 71 CL	89979-12	219132	219161	7/32
20" PM 370 GX 71 CL	88173-12			
20" PMR 370 GLX 71 CL	218069-12			
20" SPG 320 GLX 79 CL	218552-12	219130	98023	11/64
24" SPR 370 GX 81 CL	89981-12			
24" PM 370 GLX 81 CL	88175-12			
24" PMR 370 GLX 81 CL	218070-12			
24" SPR 370 GX 82 CL	89982-12	219232	219861	7/32
24" PM 370 GX 82 CL	93551-12			
28" SPR 370 GX 92 CL	89984-12			
28" PM 370 GX 93 CL	93552-12			
33" SPR 370 GX 106 CL	92101-12			

* = NOT AVAILABLE

FIGURE 3 POWERHEAD ASSEMBLY

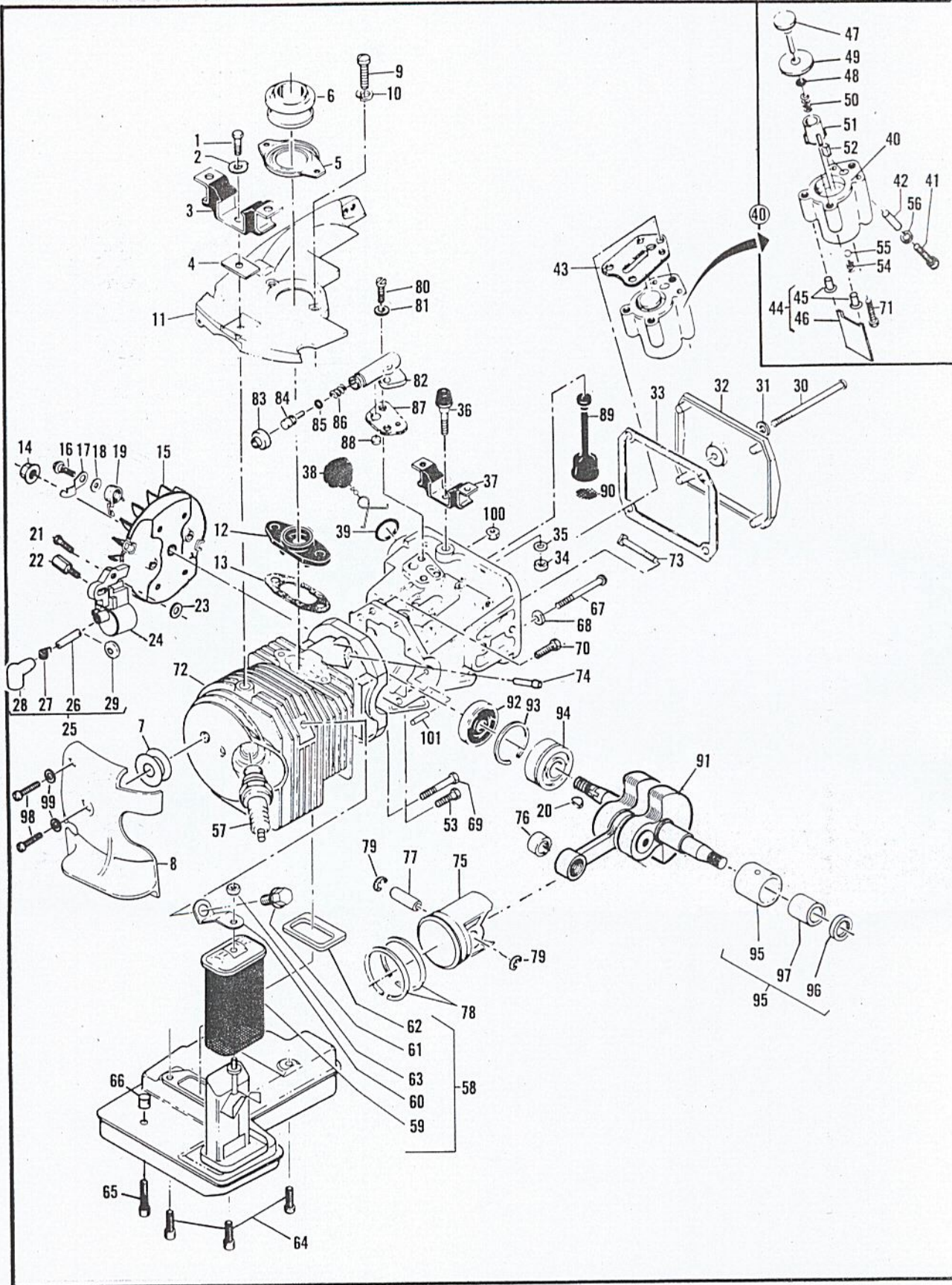

FIGURE 3 POWERHEAD ASSEMBLY

ITEM NO.	STK. CODE	PART NUMBER	DESCRIPTION	UNITS PER ASY.
1	B	83811	Screw, Special	1
2	B	69924	Plate, Lock	1
3	A	93925	Mount, Rear	1
4	C	84619	Insulator, Rear Mount	1
5	B	213381	Clamp Assembly, Upper Boot	1
6	A	215247	Boot, Third Port .50	1
7	A	93460	Washer, Insulated	1
8	C	300711	Shroud, Rear Cylinder (Grey)	1
9	A	104396	Screw, PN 10-24.75 (55-60 in. lbs. torque)	2
10	C	101194	Washer, Lock #10 SHK PRF	2
11	A	300131	Shroud, Upper Cyl.	1
12	B	87844	Insulator, Inlet	1
13	A	88740	Gasket, Inlet Insulator	1
14	B	110703	Nut, Hex Flange 3/8-24 (265-325 in. lbs. torque)	1
15	B	95481	Flywheel/Pawl Assembly	1
16	B	93464	. Screw, Pawl Pivot	2
17	A	93198	. Pawl, Starter	2
18	B	93469	. Washer, Starter Pawl	2
19	A	214102	. Spring, Starter Pawl	2
20	A	100106	Key, Woodruff	1
21	A	110127	Screw, Hex 10-24x.88 SEMS (55-60 in. lbs. Torque)	1
22	B	95603	Stud, Special (55-60 in. lbs. torque)	1
23	C	223637	Spacer .21ID x .44 OD x .12	2
24	A	223708	Kit, Ignition Assembly	1
25	A	223884	. Kit, Spark Plug Wire	1
26	B	---	.. Wire-7mm Ignition	1
27	B	102556	.. Connector, Spark	1
28	B	95266	.. Boot, Spark Plug	1
29	B	110995	.. Grommet, Spark Plug Wire	1
	B	215533-01 ①	.. Grommet, H/T Lead	1
30	B	216630	Screw-PN 24X2.60	1
31	C	110921	Washer, Sealing	1
32	C	300712	Cover, Oil Tank (Grey)	1
33	A	86306	Gasket, Cover	1
34	C	101143	Nut, Hex 1/4-20 (90-100 in. lbs. torque)	1
35	B	102523	Washer, 1/4 Plain	1
36	C	69832	Bumper, Front	1
37	A	93926	Mount, Front	1
38	A	216052	Cap Assembly, Oil Tank	1
39	A	101148	"O" Ring	1
40	A	215339	Kit, Pump Tested	1
41	A	217936	. Screw-TR, 10-24x.75 Torx	1
42	C	91774	. Sleeve-Pulse Pump	1
43	A	92818	. Seal, Pulse Pump	1
44	A	215246	. Kit, Oil Pump	1
45	---	---	.. Eyelet	2
46	---	---	.. Spring Clip-Oil Pump	1
47	A	214278	. Piston Assembly, Oiler	1
48	A	105603	.. "O" Ring, .114x.070	1
49	B	86182	.. Ring-Piston Pulse Oiler	1
50	A	60259	. Spring, Piston Oiler	1
51	C	62227	. Sleeve, Adjustment	1
52	B	91259	. Pad, Oil Pump	1

ITEM NO.	STK. CODE	PART NUMBER	DESCRIPTION	UNITS PER ASY.
53	C	110963	. Screw, Hex 8-32x1 WSH	1
54	---	---	. Spring-Oiler CN/Valve	1
55	---	---	. Ball, Outlet Valve	1
56	A	100003	Washer-#10	1
57		63432	Spark Plug	1
58	B	216160	Muffler, Assembly	1
59	B	214283	. Screen/Cap Assembly	1
60	C	216087	. Strap, Muffler	1
61	C	214100	. Screw, Special 3/8-THD (110-120 in. lbs. torque)	1
62	B	95387	. Gasket, Muffler	1
63	A	216682	. Nut, Hex Lock 10-24 (40-45 in. lbs. torque)	1
64	B	104895	. Screw, Skt 10-24x.62 (65-75 in. lbs. torque)	3
65	A	110713	. Screw, Skt 10-24x.88 (65-75 in. lbs. torque)	1
66	C	223637	. Spacer .21 ID x .44 OD x .12	2
67	A	224996	Screw, Sealing #12x24x2.09 (60-65 in. lbs. torque)	4
68	B	111025	Washer-Sealing Alum.	4
69	B	110644	Screw, Hex Wsh 8-32x1.5 (30-35 in. lbs. torque)	1
70	A	110288	Screw, Hex Wsh 8-32x.75 (30-35 in. lbs. torque)	3
71	C	110963	Screw, Hex Wsh 8-32x1.0 (30-35 in. lbs. torque)	1
72		300740	Kit, Cylinder 82cc	1
73	A	92459	. Bolt, Bar	2
74	C	69600	. Nipple, Pulse Line	1
75	B	300687	Kit, Piston	1
76	A	224971	. Bearing, Wrist Pin	1
77	---	---	. Pin, Wrist	1
78	A	87854	. Rings, Piston	2
79	A	224969	. Ring, Retaining	2
80	B	110338	Screw, Hex 8-32x.532 (15-20 in. lbs. torque)	2
81	B	110613	Washer, #8 Hard	2
82	A	84156	Housing, Oil Pump	1
83	A	215151	Cap, Oil Pump	1
84	B	92902	Plunger, Pump	1
85	A	105614	"O" Ring	1
86	B	66687	Spring, Plunger	1
87	A	91669	Gasket, Oil Pump Housing	1
88	A	91668	Valve, Oiler	1
89	A	91672	Hose Assembly, Oil Pick Up	1
90	B	51506	. Screen, Oil Pump	1
91	A	224943	Crankshaft/Rod Assembly	1
92	A	61618	Seal, Oil	1
93	B	63464	Ring, Snap	1
94	A	63429-02	Bearing, Ball	1
95	A	87151	Insert, Bearing Asy. (Needle)	1
96	A	110260	. Seal, Oil	1
97	A	104357	. Bearing, Needle	1
98	A	216634	Screw-PN HD 10-24x2.62	2
99	A	100002	Washer-#10 Plain	2
100	B	100955	Nut-HX Lock 8-32	1
101	C	110851	Pin-Dowel	1

① Not Illustrated. Included in Spark Plug Wire Kit, P/N 223884 which is a universal kit. Please discard Grommet, H/T Lead and use Grommet, Spark Plug Wire, P/N 110995 for installation on Pro Mac 8200.

FIGURE 4 FUEL TANK ASSEMBLY

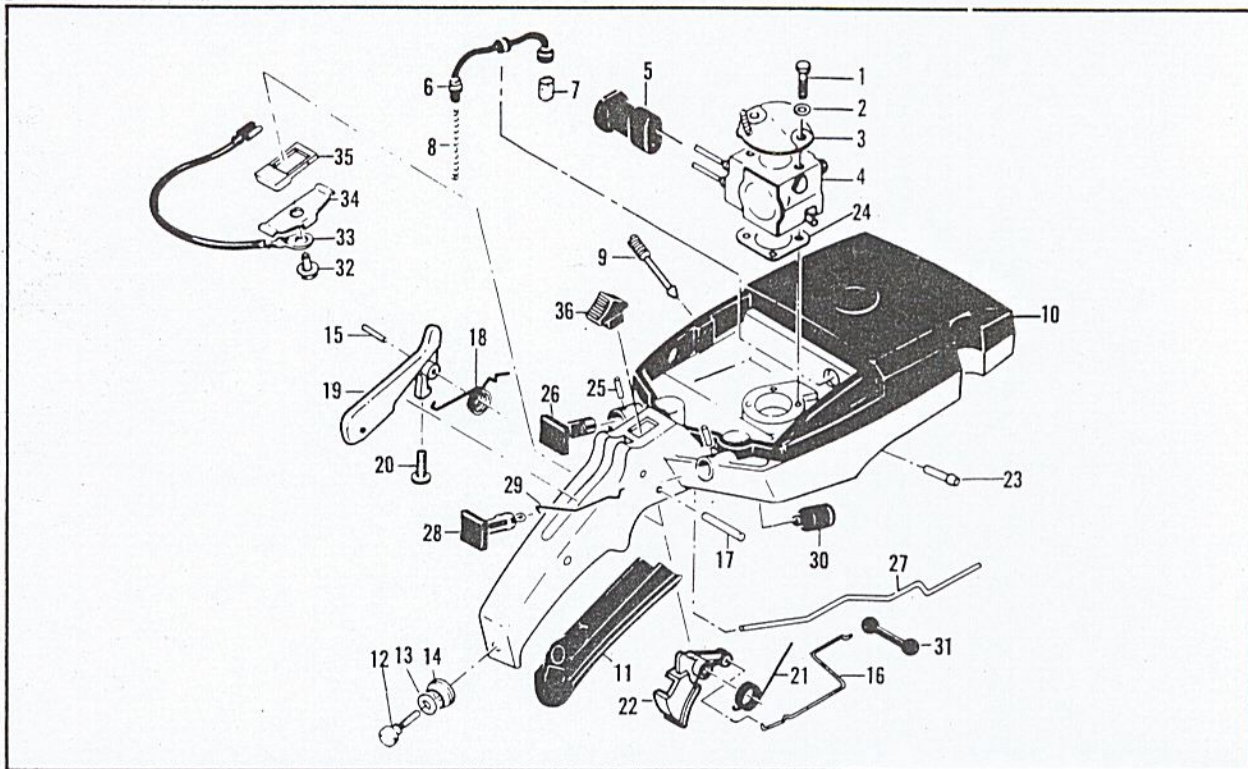

ITEM NO.	STK. CODE	PART NUMBER	DESCRIPTION	UNITS PER ASY.
1	A	103357	Screw-HX-HD 10-24 X 2.25	2
2	C	110964	Washer-Plain	2
3	C	95414	Bracket-Air Cleaner	1
4		Figure 7	Carburetor Assembly	1
5	C	214762-01	Boot-Carburetor	1
6	A	215708	Hose Assembly-Fuel	1
7	A	215714	Pickup Assembly-Fuel	1
8	B	67944	Spring hose Stiffner	1
9	C	86273	Screw-Idle Speed	1
10	B	94025	Tank Assembly-Fuel	1
11	A	89320	Insert-Handle Grip	1
12	C	213055	Screw-BTN 10-24 x 1.50 S	1
13	B	214764	Washer	1
14	B	93032	Grommet-Frame Brace	1
15	C	105654	Pin-Roller 0.131 x 0.875	1
16	C	92155	Rod-Throttle	1
17	C	110378	Pin-Roll 0.196 x 0.937	1
18	B	92154	Spring-Throttle Release	1

ITEM NO.	STK. CODE	PART NUMBER	DESCRIPTION	UNITS PER ASY.
19	B	94275	Release Assembly-Trigger	1
20	B	111012	Screw-PN HD 4-40x 0.31 ST	1
21	A	92152	Spring-Trigger	1
22	A	214679	Trigger-Throttle	1
23	C	69600	Nipple-Pulse Line	1
24	A	86189	Gasket-Carburetor	1
25	B	105673	Pin-Roll .099 x .562	2
26	C	95480	Button-Oiler Asy.	1
27	C	92903	Rod-Oiler	1
28	C	95614	Button-Choke	1
29	B	69631	Rod Choke	1
30	A	69597	Boot-Control Rod	2
31	A	69043	Snubber-Rod	1
32	A	110706	Screw-PH HD 8-18 x 1/2	1
33	B	83661-01	Wire Assembly-Stop Switch	1
34	B	62451	Contact-Ignition Switch	1
35	B	214691	Base-Stop Switch	1
36	A	68846	Button-Stop Switch	1

CHAIN BRAKE ASSEMBLY **FIGURE 5**

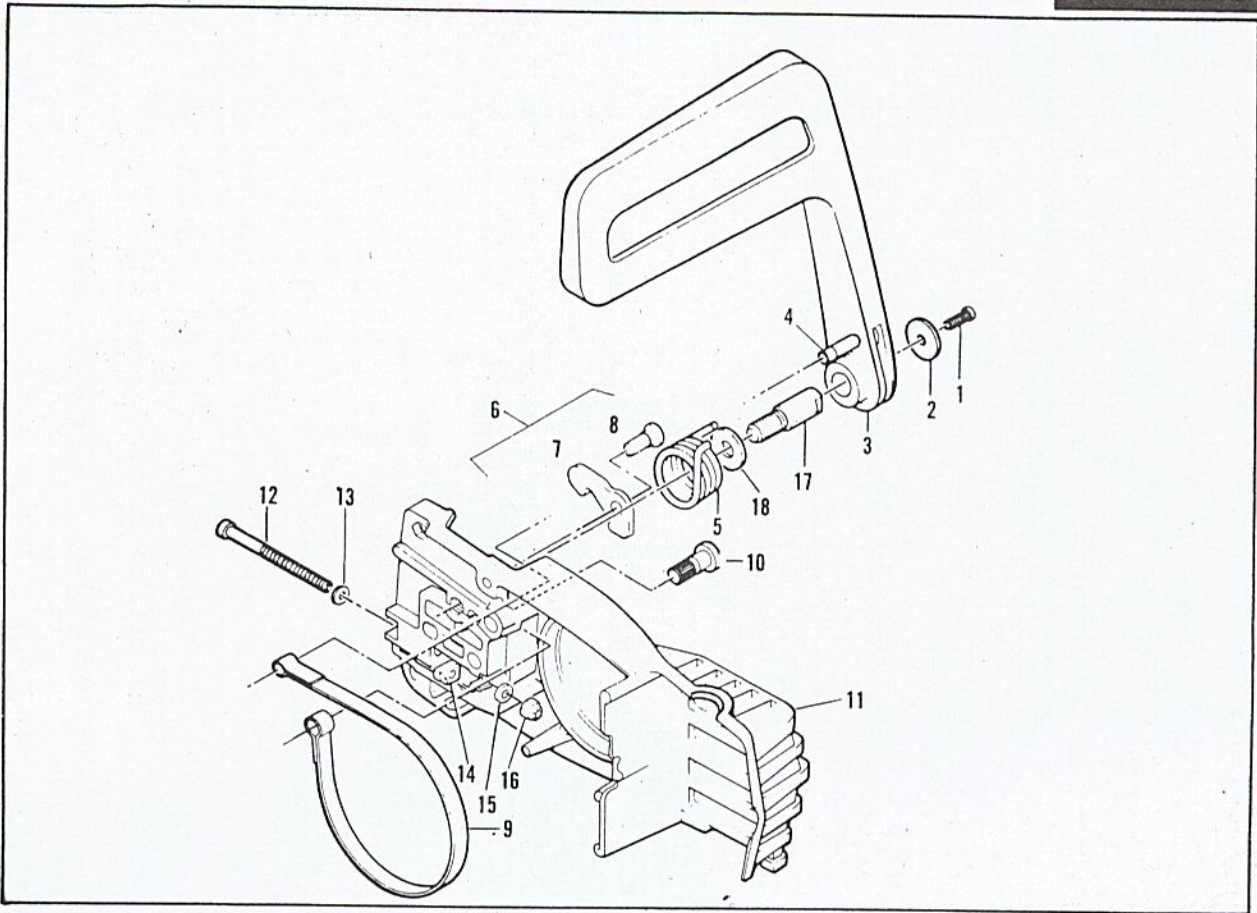

ITEM NO.	STK. CODE	PART NUMBER	DESCRIPTION	UNITS PER ASY.
	C	21769	Brake Assembly-Chain	1
1	A	216634	. Screw-10-24 x 1/2	1
2	B	216633	. Washer-Special	1
3	B	215911	. Lever Assembly	1
4	A	214366	.. Pin Asy.-Roller	1
5	B	93085	. Spring-Brake	1
6	A	222478	① . Kit-Latch/Pivot	1
7	---	---	.. Latch-Chain Brake	1
8	---	---	.. Pivot-Latch	1
9	A	93081	. Band-Brake	1

ITEM NO.	STK. CODE	PART NUMBER	DESCRIPTION	UNITS PER ASY.
10	B	93082	. Pin-Band Anchor	1
11	---	---	. Housing-Brake	1
12	A	216636	. Screw-Bar Adjusting	1
13	A	216635	. Washer- # 10	1
14	A	61705	. Nut, blade Adj.	1
15	A	100002	. Washer-#10	1
16	A	216682	. Nut- 10-24 Lock	1
17	B	91246	. Pin-Lever Pivot	1
18	B	91245	. Washer-Thrust	1

① When replacing either the Latch or Pivot, you must order part number 222478, and replace both Pivot and Latch simultaneously.

FIGURE 6 FAN HOUSING & STARTER ASSEMBLY

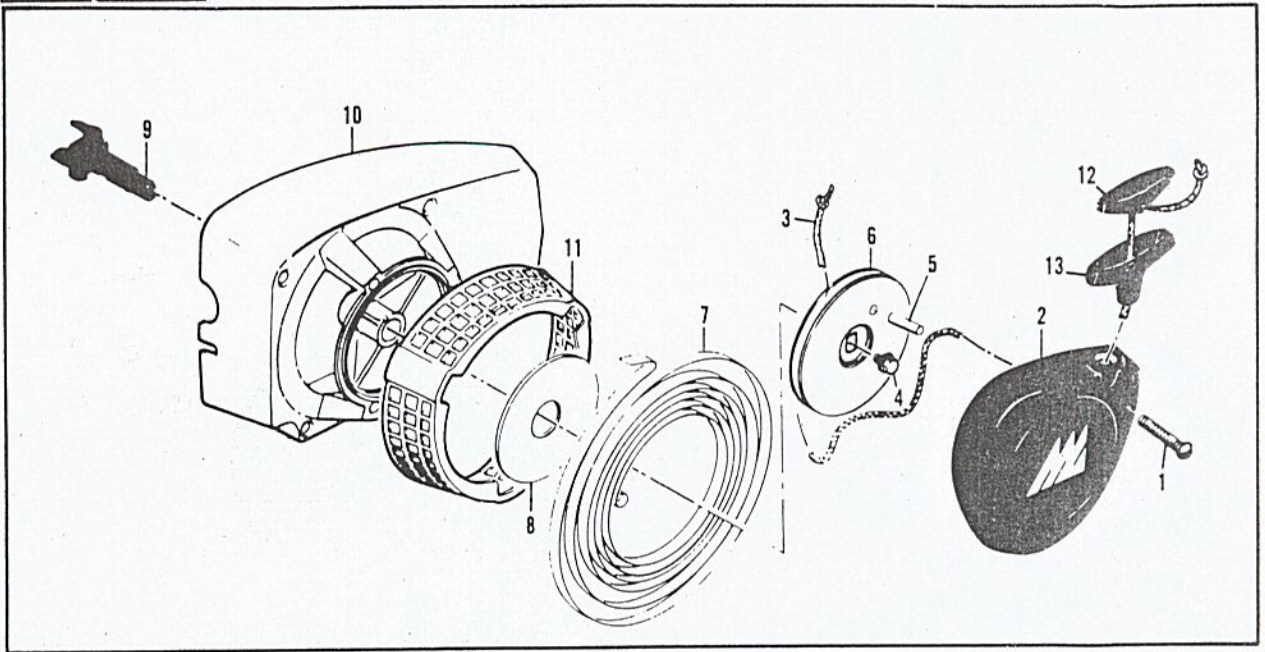

ITEM NO.	STK. CODE	PART NUMBER	UNITS PER DESCRIPTION	UNITS PER ASY.
	C	300709	Fan Housing & Starter Asy.	1
1	A	215682	. Screw-OV 10-24 x 1.25	3
2	C	300713	. Cover, Starter	1
3	A	87670	. Rope-Starters (45")	1
4	A	217935	. Screw-TR 10-24 x 0.50	1
5	C	105841	. Pin-Roll	1
6	B	87689	. Drum-Starters	1

ITEM NO.	STK. CODE	PART NUMBER	DESCRIPTION	UNITS PER ASY.
7	B	87680	. PKG, Spring-STR./Rewind	1
8	A	86053	. Shield-Spring	1
9	B	95412	. Shaft Assembly-Starters	1
10	B	215777	. Kit-Fan Housing	1
11	A	214192	. Guard-Sawdust	1
12	A	214699	Insert-Starters	1
13	A	93137	Handle	1

CARBURETOR ASSEMBLY **FIGURE 7**

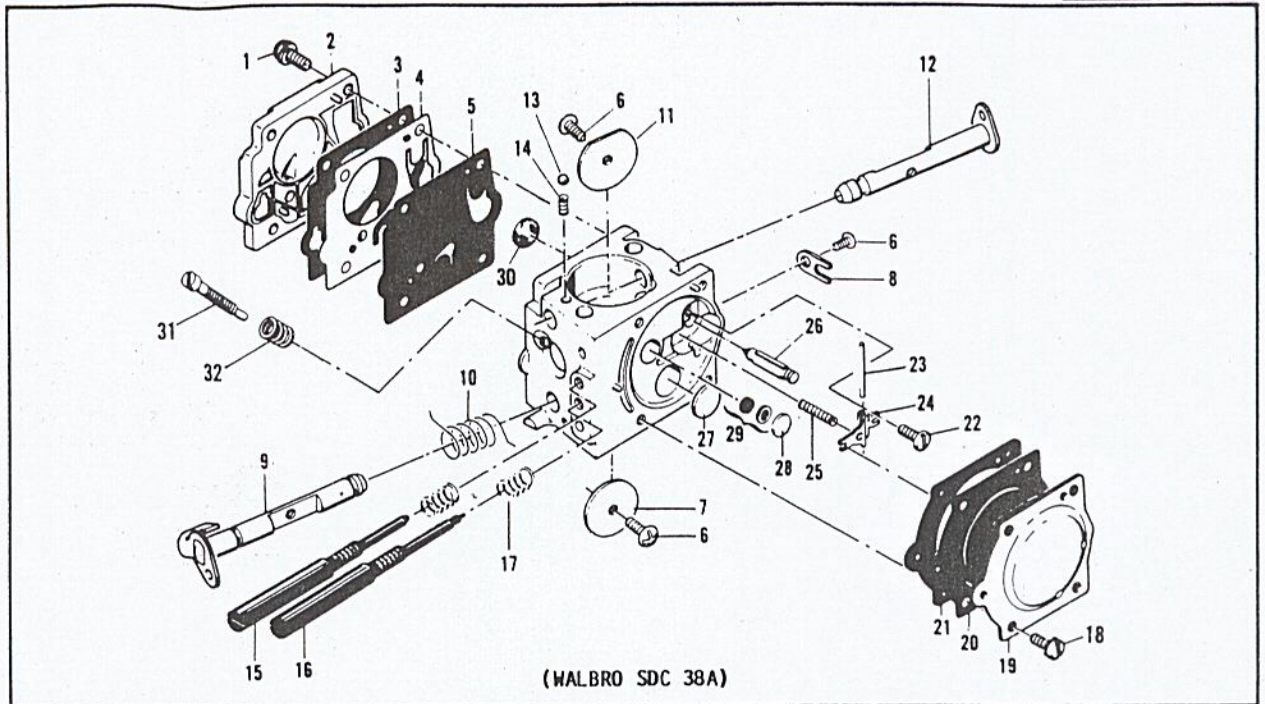

ITEM NO.	STK. CODE	PART NUMBER	DESCRIPTION	UNITS PER ASY.
	B	214763-02	Carburetor Asy (SDC 38A)	1
1	---	---	. Screw-Pump Cover	1
2	---	---	. Cover-Pump	1
3	---	①②	. Gasket-Cover	1
4	---	①②	. Diaphragm-Check Valve	1
5	---	①②	. Diaphragm-Fuel Pump	1
6	---	①	. Screw-Plate	2
7	---	---	. Plate-Throttle	1
8	---	---	. Clip-Shaft	1
9	---	---	. Shaft Asy Throttle	1
10	---	①	. Spring-Throttle Return	1
11	---	---	. Plate-Choke	1
12	---	---	. Shaft Asy-Choke	1
13	---	①	. Ball-Choke Friction	1
14	---	①	. Spring-Choke Friction	1
15	---	①	. Needle-High Speed	1
16	---	①	. Needle-Idle	1

ITEM NO.	STK. CODE	PART NUMBER	DESCRIPTION	UNITS PER
17	---	---	① . Spring-Needle	2
18	---	---	. Screw-Diaphragm	4
19	---	---	. Cover-Diaphragm	1
20	---	①②	. Diaphragm-Metering	1
21	---	①②	. Gasket-Diaphragm	1
22	---	①	. Screw-Level Pin	1
23	---	①	. Pin-Lever	1
24	---	①	. Lever-Inlet	1
25	---	①	. Spring-Lever	1
26	---	①	. Valve-Needle	1
27	---	①	. Plug-3/8	1
28	---	①	. Plug-5/16	1
29	---	83758	. Kit-Valve & Seal Asy	1
30	---	①	. Screen-Fuel	1
31	---	①	. Screw-Idle Adj.	1
32	---	①	. Spring-Idle Screw	1

NOTE:

Items are shown for identification and disassembly sequence purposes only. Components are not available individually. Kits listed are the only service parts available.

① Included in Major Repair Kit P/N 217080 (A)

② Included in Gasket/Diaphragm Kit P/N 219248 (B)

FIGURE 8 SPECIFICATIONS

DISPLACEMENT	5.0 Cubic inch (82cc)
BORE & STROKE	2.062 inches x 1.500 inches (52.4mm x 38.1mm)
SPARK PLUG	CHAMPION DJ6J
SPARK PLUG GAP	0.025 INCHES (63MM)
FUEL TANK CAPACITY	25.6 Fluid Ounces
OIL TANK CAPACITY	9.6 Fluid Ounces (760cc)
INTAKE SYSTEM	3rd Port Piston Timed
CLUTCH ENGAGEMENT SPEED	2800 to 3000 RPM
COIL LAMINATION TO FLYWHEEL AIR GAP	.011 to 0.015 INCHES (28-38MM)
IGNITION	Captive Discharge (CDI)
TIMING	26° BTDC
MAIN BEARING	Needle and Ball
CONNECTING ROD BEARING	Needle
SPROCKET TYPE	Floating Rim Sprocket 7 Tooth, .0375 Pitch
WEIGHT POWER UNIT ONLY	17.2 Pounds (7.8kg)
FUEL	Regular or Unleaded (Use only one type)
FUEL/OIL RATIO	32:1 McCulloch Custom Lubricant (20:1 Two Cycle Oil Other Than McCulloch Custom Lubricant)
CARBURETOR	Walbro SDC 38A Two Needle External Adjustment Internal Idle Speed Adjustment

TOOLS

91226	Tool-Clutch Holding
69191	Kit-Pressure Test
214221	Scrench

LOCTITE KIT

PART NUMBER	DESCRIPTION
322235	LOCTITE KIT
322236	. RETAINING COMPOUND 620 (10 ml)
322237	. THREAD LOCKER 242 (10 ml)
322238	. GASKET ELIMINATOR 518 (50 ml)
322239	. BLACK MAX ADHESIVE 380 (01 oz)