

ILLUSTRATED PARTS LIST

Pro Mac™ 610 MODELS	SERIAL NUMBER PREFIX	Pro Mac™ 650 MODELS	SERIAL NUMBER PREFIX
600041-01	12-,13-	600046-01	12-
600041-02	11-,12-,13-	600046-02	11-,12-
600041-03	11-,12-	600046-03	11-,12-
600041-04	11-,12-	600046-04	11-,12-
600041-05	11-,12-	600046-06	11-
600041-06	11-,12-	600046-07	11-,12-
600041-07	11-,12-	600046-08	11-,12-
600041-08	11-,12-	600046-09	11-
600041-09	12-	600046-11	11-,12-
600041-10	11-,12-,13-	600046-14	11-,12-
600041-11	11-,12-,13-	600046-18	11-
600041-12	11-,12-	600046-19	11-,12-
600041-14	11-,12-	600046-20	11-
600041-15	11-,12-	600046-21	12-
600041-17	11-,12-,13-	600046-22	11-
600041-18	11-,12-	600046-23	11-
600041-19	11-,12-		
600041-21	11-,12-	Pro Mac™ 605	SERIAL
600041-22	12-,13-	MODELS	NUMBER
600041-23	12-,13-		PREFIX
600041-24	12-,13-	600134-02	11-
		600134-03	11-
Super	SERIAL	600134-04	11-
Pro Mac™ 610	NUMBER	600134-05	11-
MODELS	PREFIX	600134-06	11-
600041-04	13-	E.B.® 3.7	SERIAL
600041-06	13-	MODELS	NUMBER
600041-09	13-		PREFIX
600041-15	13-	600133-02	11-,12-
600041-21	13-	600133-03	11-,12-
600041-27	13-	600133-04	11-,12-
600041-28	13-	600133-05	12-
		600133-06	12-

SUPER 610 PRO MAC™ 605, 610, 650 and EAGER BEAVER® 3.7 CHAIN SAWS

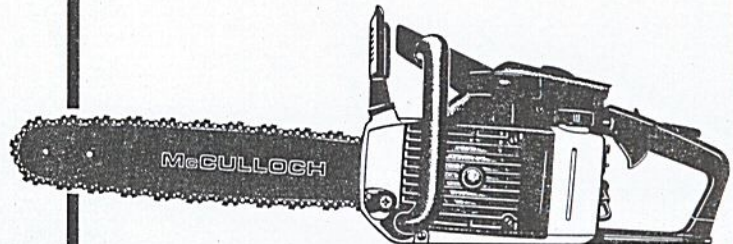

JUNE 1987

McCulloch and Eager Beaver® chain saws are identified by a model number (in this instance, 600041, 600046, etc.) followed by a suffix number (01, 02, etc.) stamped on the identification plate attached to the saw. Suffix numbers denote variations in parts or assemblies in the manufacture of the saw.

Part numbers listed in this I.P.L. which have a circled number ② or numbers preceding the description, are used only on the model or models identified by a circled number ② or numbers.

Part numbers which have one or more dots (.) preceding their descriptions may be ordered individually, but they are also included in the kit or assembly whose description begins directly above the dot(s).

The policy of McCulloch Corporation is one of continual improvement in design, manufacturing and engineering advancement wherever possible to assure still finer two-cycle power tools. Hence, specifications, equipment, colors, design and manufacturer's suggested list prices are subject to change without notice and McCulloch Corporation reserves the right to make such changes without prior notification or obligation to backfit or supply backfit components for units previously shipped from the factory.

- CONTENTS -

	Page
FIGURE 1. General.....	2
FIGURE 2. Powerhead and Oiler Assemblies.....	4
FIGURE 3. Chain Brake Assemblies.....	6
FIGURE 4. Fan Housing and Fuel Tank Asy..	7
FIGURE 5. Carburetor Assembly.....	7
(All models except PM 650)	
FIGURE 6. Carburetor Assemblies.....	8
(PM 610 and 650 models)	
FIGURE 7. Specifications.....	9
FIGURE 8. Bar/Chain/Sharpening Tools.....	9
FIGURE 9. Tools and Accessories.....	9
Figure 10. Service Notes.....	10

© U.S.A. - McCulloch Corporation, 1987

Printed in U.S.A.

McCULLOCH
CORPORATION

218689-02

This IPL replaces and supersedes IPL 215036, IPL 219202 and IPL 218689 and 218689-01.

Figure 1 GENERAL ASSEMBLY

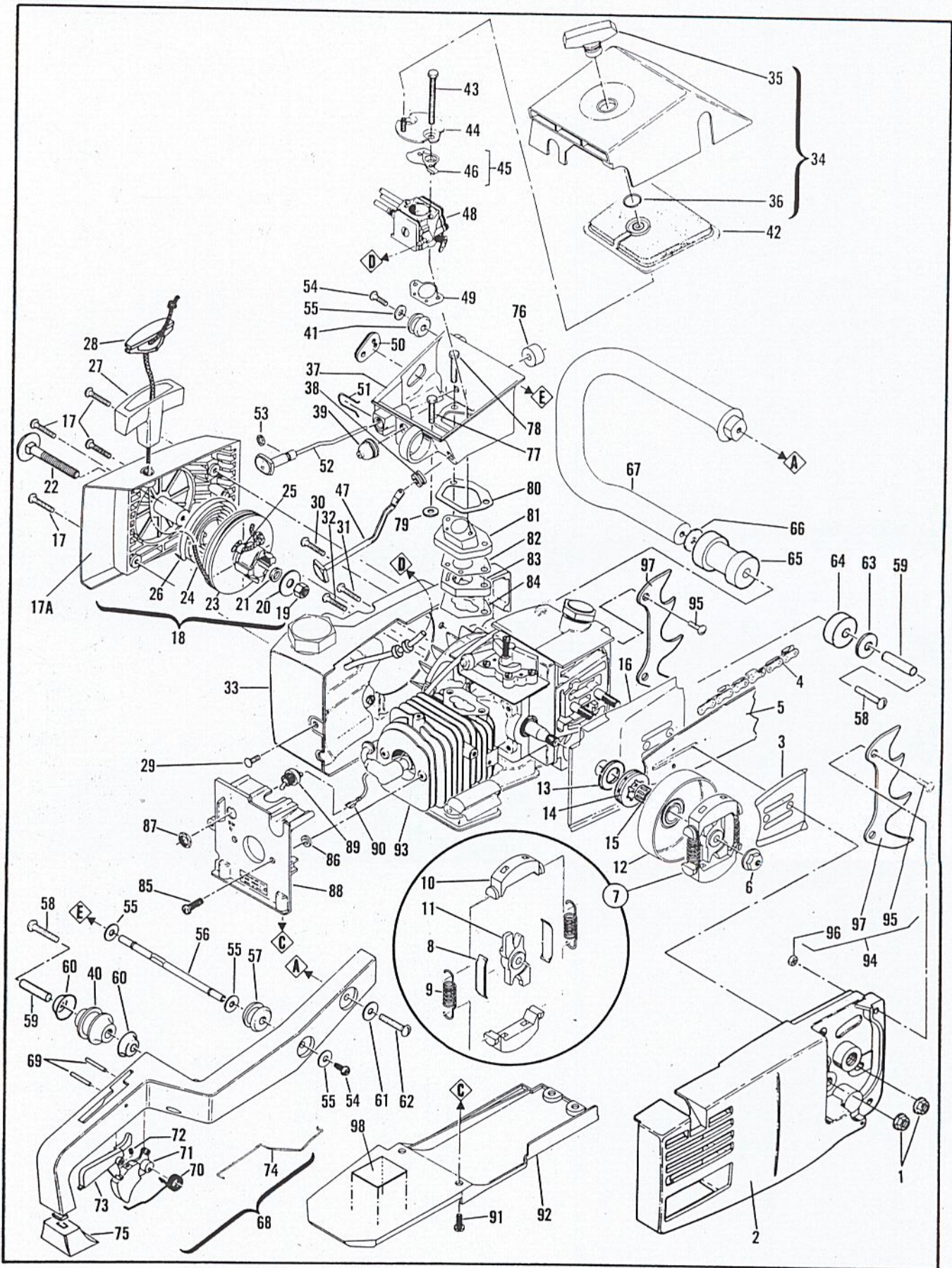

FIGURE 1 GENERAL ASSEMBLY

ITEM NO.	PART NUMBER	DESCRIPTION	UNITS PER ASY.	ITEM NO.	PART NUMBER	DESCRIPTION	UNITS PER ASY.
1	216645	Nut - Hex Flange	1	49	91924	Gasket - Carburetor	1
2	Fig. 3	Chain Brake Assembly	1	50	91995-01	Grommet - Carburetor Needle	1
3	64325	Plate - Bar Guide	1	51	93458	Clip - Oiler Button	1
4	Fig. 8	Chain Assembly	1	52	92067-01	Button/Rod Asy. - Oiler	1
5	Fig. 8	Bar Assembly	1	53	105614	"O" Ring	1
6	92457	Nut - Hex Flange M10 x 1.25 (160-170 in. lb. torque)	1	54	215266	Screw-M5 Special (25-30 in. lb. torque)	2
7	214301	Clutch Assembly	1	55	110990	Washer	4
8	64583	. Retainer - Clutch Spring	2	56	93252-01	Strut - Handle	1
9	83223	. Spring - Clutch	2	57	93253	Grommet - Strut	1
10	67233	. Kit - Clutch Shoe	1	58	111015	Screw - Pan Hd 1/4-14 x 2.5 (70-80 in. lb. torque)	2
11	214300	. Rotor - Clutch	1	59	92071	Spacer	2
12	① 214979	Drum/Sprocket Assembly	1	60	92066	Cup - Isolator	2
	② 95165	Kit - Drum/Sprocket Assembly	1	61	102115	Washer - Plain	1
	③ 95166	Kit - Drum/Sprocket Assembly	1	62	111014	Screw - Pan Hd 1/4-14 x 1.75 (70-80 in. lb. torque)	1
13	① 86958	. Washer - Shim	1	63	111027	Spacer	1
14	② 86951	. Sprocket - 7T .375P (Floating Rim)	1	64	93913	Isolator (Used on All Models except 650 46-10)	1
	③ 86344	. Sprocket - 7T .375P	1		94847	Isolator (Used on 650 46-10 Only)	1
15	110971	Bearing - Needle	1	65	94140	Isolator	1
16	92354	Jacket - Cylinder	1	66	111027	Washer - Plain	1
17	120081	Screw - M4 x 16 Starter (15-20 in. lb. torque)	4	67	91951	Frame	1
17A	⑤ ⑥ 219976	Housing - Starter	1	68	214723	Handle Assembly	1
18	⑤ ⑥ 219159	Starter/Drum Assembly	1	69	110994	. Pin - Roll	2
	④ 95353	Starter Asy (Less Drum Asy)	1	70	93771	. Spring - Trigger	1
19	111038	. Nut - 1/4-20 (25-30 in. lb. torque)	1	71	93538-01	. Trigger	1
20	95401	. Washer - Starter	1	72	111013	. . Screw - Set	1
21	216589	. Spacer - Starter	1	73	91955	. Release - Trigger	1
22	215848	. Step Bolt - Starter	1	74	214504	. Rod - Throttle	1
23	⑤ ⑥ 219163	. Drum Asy	1	75	93459	Boot - Handle	1
	④ 216758	. Drum Asy	1	76	92161	Seal - Air Box	1
24	87670	. . Rope - Starter	1	77	120037	Screw - Hx Hd M5 x 25 (SEMS) (35-40 in. lb. torque)	1
25	217730	. . Bushing - Rope	1	78	120039	Screw - Hx Hd M5 x 30 (SEMS) (35-40 in. lb. torque)	2
26	87680	Spring - Starter Rewind	1	79	93460	Washer - Insulator	1
27	93137	Starter Handle	1	80	94018	Gasket - Air Box	1
28	214699	Insert Handle	1	81	94017-01	Insulator - Carburetor	1
29	120002	Screw - Pan Hd M5 x 14 (30-35 in. lb. torque)	1	82	91933	Gasket - Air Box	1
30	93232	Screw - Fan Housing M5 x 40 (45-50 in. lb. torque)	1	83	91934	Insulator - Air Box	1
31	93233	Screw - Fan Housing M5 x 35 (45-50 in. lb. torque)	1	84	92038	Gasket - Insulator	1
32	93234	Screw - Fan Housing M5 x 30 (45-50 in. lb. torque)	1	85	120037	Screw - Hx Hd M5 x 25 (SEMS) (45-50 in. lb. torque)	2
33	Fig. 4	Fan Housing/Fuel Tank Asy.	1	86	93460	Washer - Insulator	2
34	217651	Cover Assembly - Air Filter	1	87	104810	Nut - Hx 15/32-32 (30-35 in. lb. torque)	1
35	91991	. Knob - Air Filter Cover	1	88	218561	Shroud - Cylinder	1
36	110565	. Ring - Retaining	1	89	93890	Switch - Ignition	1
37	95216	Air Box Assembly	1	90	92466	Wire Assembly - Switch	1
38	93261	. Grommet - Choke	1	91	120002	Screw - Pan Hd M5 x 14 (45-50 in. lb. torque)	4
39	69597	. Boot - Control Rod	1	92	214670	Shroud - Bottom	1
40	92065	. Isolator	1	93	Fig. 2	Powerhead and Oiler Asy.	1
41	93253	. Grommet - Strut	1	94	214208	Kit - Bucking Spike	1
42	214226	Filter - Air	1	95	120002	. Screw - Pan Hd M5 x 14	4
43	120004	Screw - Hx Hd M5 x 56 (35-40 in. lb. torque)	2	96	120044	. Nut - Hx M5 Lock	2
44	91938	Bracket Asy. - Air Cleaner	1	97	93668	. Spike - Bucking	2
45	94482	Choke and Rod Kit	1	98	219058	Safety Decal	1
46	94151	. Choke - Carburetor	1				
47	94171	. Rod - Choke	1				
48	Fig. 5,6	Carburetor Assemblies	1				

① Used on 12 and 13 level PM 610 units, all Super PM 610, all PM 605 and Eager Beaver® 3.7 units.

② Used on all 11 level PM 610/650 units, except models with suffix letter A (-01).

③ Used on all 11 level PM 610/650 units and models with suffix letter A (-01).

④ ⑤ All PM 610/650 models:

If starter Housing Drum Mounting Post indicates a taper of .045 from top to bottom, order ⑤ components. If post measures the same from top to bottom (has no taper), order ④ components.

⑥ Used on all PM 605; all Super PM 610 and all Eager Beaver® 3.7 models.

Figure 2

POWERHEAD & OILER ASSEMBLIES

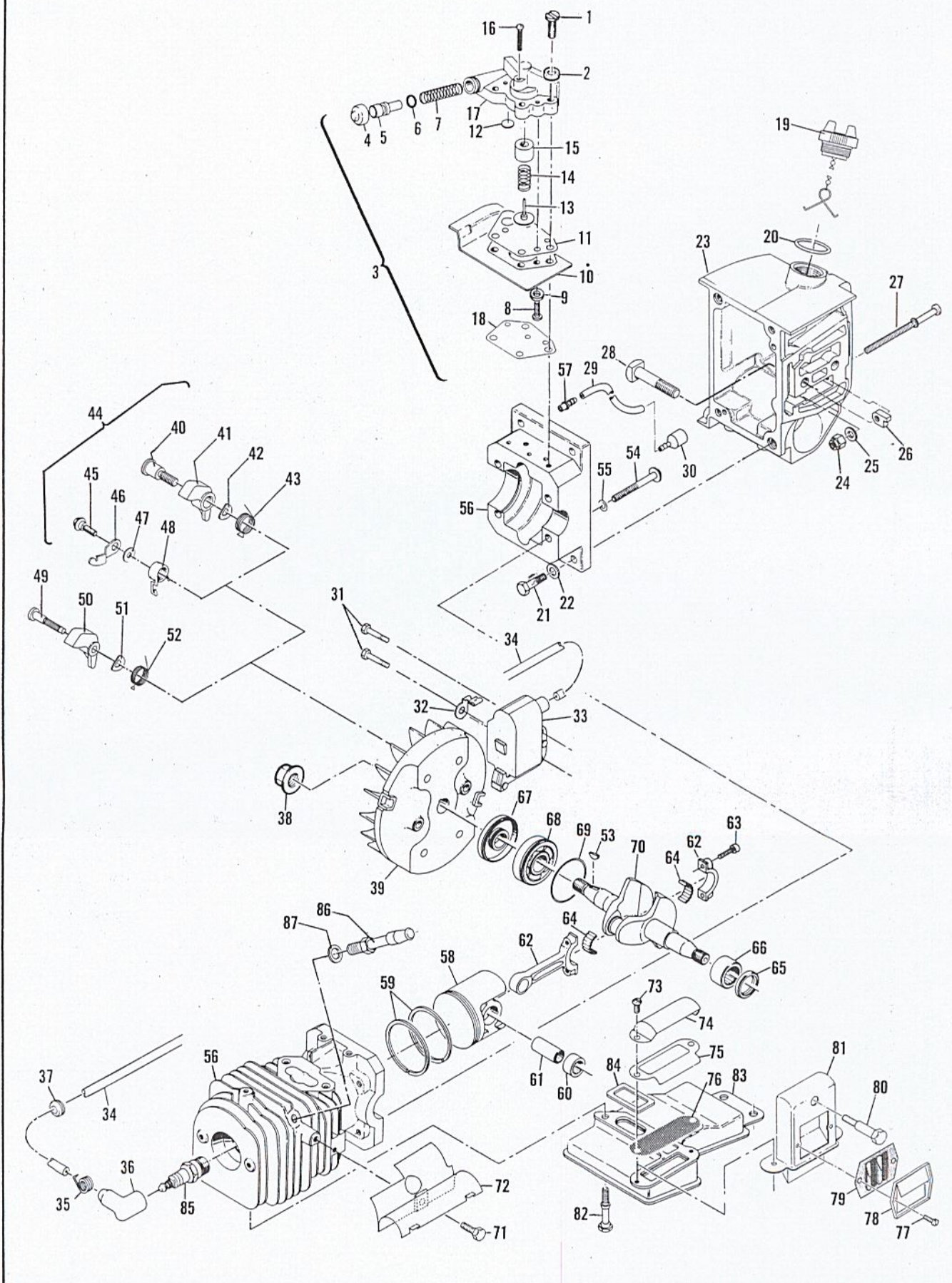

POWERHEAD & OILER ASSEMBLIES

ITEM NO.	PART NUMBER	DESCRIPTION	UNITS PER ASY.
1	120036	Screw-M4x16 (Sems)	4
2	67177	Washer-Insulating	4
3	219380	Pump Asy-Oiler (Pulse)	1
4	215151	. Cap	1
5	93933	. Plunger	1
6	105614	. "O" Ring	1
7	66687	. Spring-Plunger	1
8	110706	. Screw-8-18x1/2	3
9	216354	. Gasket-Washer	1
10	217218	. Cover-Diaphragm	1
11	216992	. Diaphragm	1
12	-- --	. Valve	1
13	91945	. Piston Assembly	1
14	94322	. Spring-Return	1
15	91944	. Sleeve	1
16	218530	. Screw-6-40x.875	1
17	219336	. Body Assembly	1
18	91950	Gasket-Oil Pump	1
19	216052	Cap/Retainer Asy-Oil	1
20	101148	"O" Ring	1
21	120006	Screw-M6.3x24	4
22	100004	Washer-Plain 1/4"	4
23	218583	Tank Asy-Oil	1
24	110950	. Nut-Lock	1
25	102115	. Washer-Plain	1
26	91982	. Nut-Bar Adjustment	1
27	94362	. Screw-Bar Adjustment	1
28	92459	. Bolt-Bar	2
29	92616	Hose-Oil Pickup	1
30	92465	Pickup-Oil	1
31	120037	Screw-M5x25 (Sems) (55-60 In. Lb. Torque)	2
32	84686-01	Wire Asy-Ground	1
33	95553	Ignition Asy-Electronic	1
34	95270	. Wire Asy-Spark	1
35	102556	.. Connector-Spark Plug	1
36	95266	.. Boot-Spark Plug	1
37	110995	. Grommet-Spark Plug Wire	1
38	94500	Nut-Flange M10 (265-325 In. Lb. Torque)	1
39	① 95324	Flywheel/Pawl Asy	1
40	① 95362	. Screw-Pawl	2
41	① 95361	. Pawl-Starter (Plastic)	2
42	① 213253	. Washer-Spring	2
43	① 93144	. Spring-Pawl	2
44	②③ 216739	Kit-Flywheel/Pawl	1
45	② 93464	. Screw-Pawl	2
46	② 93198	. Pawl-Starter (Metal)	2
47	② 93469	. Washer-Spring	2
48	② 214102	. Spring-Pawl	2
49	④ 93146	Pin-Pawl	2

ITEM NO.	PART NUMBER	DESCRIPTION	UNITS PER ASY.
50	④ 93145	Pawl-Starter (Plastic)	2
51	④ 93469	Washer-Spring	2
52	④ 93144	Spring-Pawl	2
53	100106	Key-Woodruff	1
54	62106	Screw-12-24x1 3/4 (70-75 In. Lb. Torque)	4
55	111025	Washer-Sealing	4
56	94536	Cyl/C'Case Asy	1
	⑤ 218814	Cyl/C'Case Asy	1
57	92096	. Nipple-Oil Line	1
58	⑥ 94130	Piston Asy	1
	⑤⑦ 219269	Piston Asy	1
59	⑧ 94132	. Ring Set-Piston	1
	⑤ 92517	. Ring Set-Piston	1
60	111021	. Bearing-Needle	2
61	87710	. Pin-Piston	1
62	85352	Rod Asy-Connecting	1
63	61627-01	. Screw-Con Rod (55-65 In. Lb. Torque)	2
64	63225	Bearing-Roller (Set of 20)	1
65	110260	Seal-Oil	1
66	104357	Bearing-Needle	1
67	67906	Seal-Oil	1
68	67905	Bearing-Ball	1
69	63464	Ring-Snap	1
70	217041	Crankshaft	1
71	102762	Screw-10-24x1/2 (55-60 In. Lb. Torque)	1
72	217607	Deflector-Exhaust	1
73	120038	Screw-M4x8 (34-45 In. Lb. Torque)	2
74	93604	Outlet-Muffler	1
75	93481	Plate-Deflector	1
76	214205	Screen-Muffler	1
77	120087	Screw-M3.5x7.5 (30-35 In. Lb. Torque)	2
78	93482	Cover-Chamber	1
79	93605	Screen-Muffler	1
80	95445	Screw-Muffler (55-60 In. Lb. Torque)	1
81	216254	Chamber Asy-Muffler	1
82	95444	Screw-Muffler (65-75 In. Lb. Torque)	2
83	93603	Muffler Asy	1
84	84007	Gasket-Muffler	1
85	62345	Spark Plug-AC CS45T	1
	93017	Spark Plug-CH RDJ6 (120 In. Lb. Torque)	1
86	⑨ 214304	Valve-DSP	1
87	⑨ 214765	Washer-DSP Valve	1

① Used on all PM 605, all Super PM 610 and all Eager Beaver® 3.7 models.

② Used on PM 610 and PM 650 11 level and 12 level models. Identify components before ordering any parts. See callout number 4.

③ This is an alternate kit that will backfit older 600 series chain saws originally equipped with metal pawls. This kit also includes those parts listed as Item Number 40, 41, 42 and 43.

④ Used on PM 610 and PM 650 11 level and 12 level models. Identify components before ordering any parts. See callout number 2.

⑤ Used on PM 605 models ONLY.

⑥ Does not include Pin, part number 87710, shown as Item Number 61.

⑦ Does not include two (2) bearings, part number 111021, listed as Item Number 60.

⑧ Before ordering Piston Ring set for PM 610 units, see Service Notes on page 10 for piston ring size.

⑨ Used on PM 650 units only. The replacement cylinder does not have a hole for the DSP valve. Parts are for service replacement only.

Figure 3 CHAIN BRAKE ASSEMBLIES

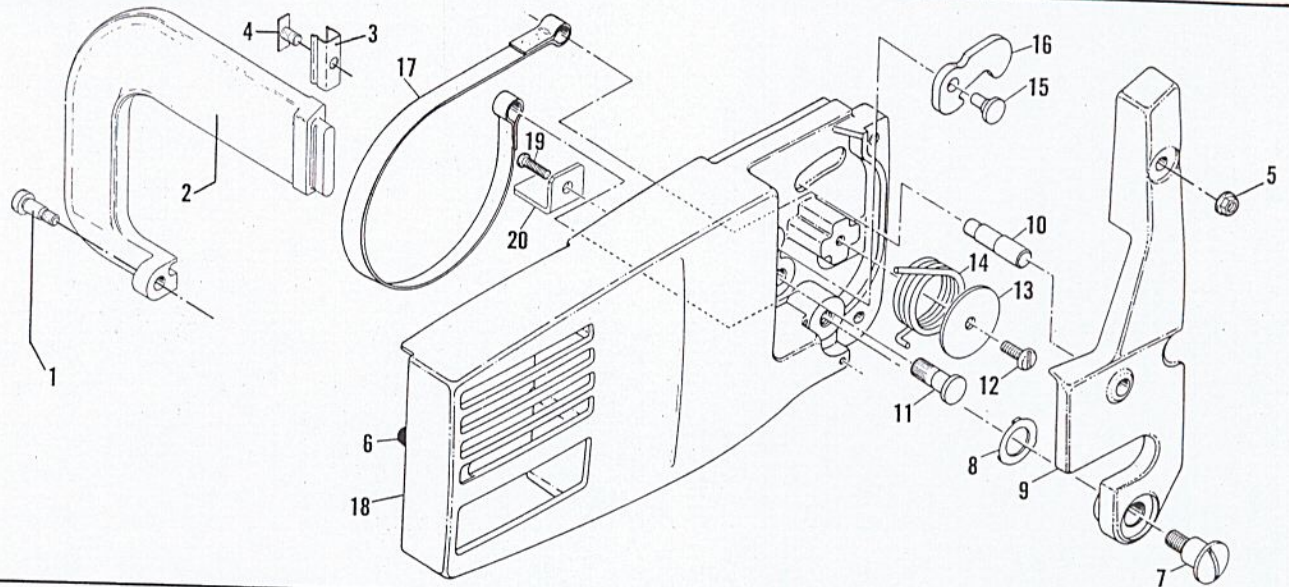

ITEM NO.	PART NUMBER	DESCRIPTION	UNITS PER ASY.
1	95671	Screw-Brake Arm	1
2	91989-02	Arm-Brake Actuator	1
3	93721	Channel-Brake Arm	1
4	93746	Stud-Brake	1
5	92457	Nut-M10x1.25	1
6	92086	Snubber	1
7	216693	Screw-Pivot	1
8	92216	Washer-Special	1
9	217000	Lever-Brake Actuator	1
10	214367	Pin Assembly-Roller	1

ITEM NO.	PART NUMBER	DESCRIPTION	UNITS PER ASY.
11	93082	Pin-Band Anchor	1
12	120019	Screw-Hx Hd M5x13	1
13	92134	Retainer-Spring	1
14	92135	Spring-Actuating	1
15	94144	Pivot-Latch	1
16	94150	Latch-Brake	1
17	93081	Band-Brake	1
18	216317	Housing-Brake	1
19	120002	Screw-Pan Hd M5x14	1
20	92178	Stop-Chain	1

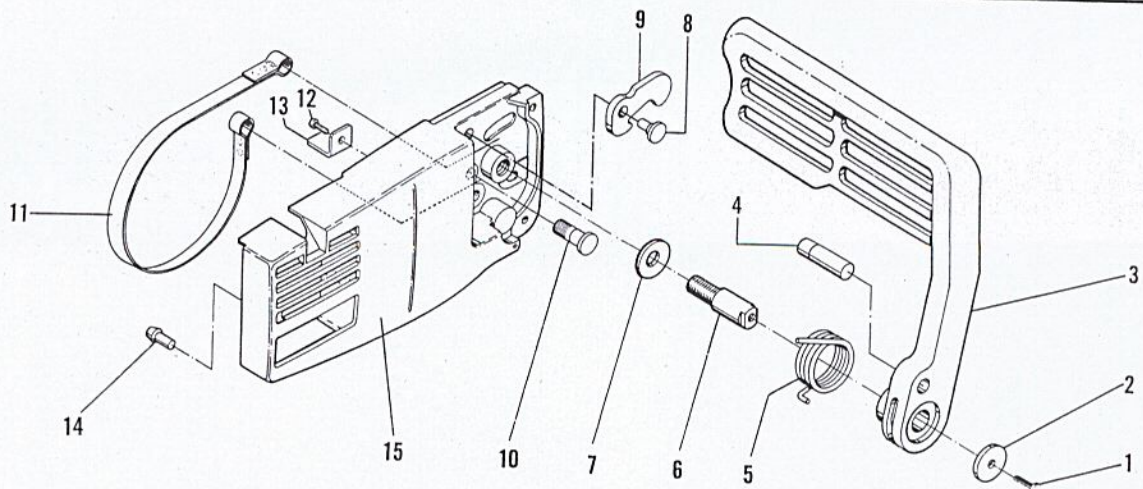

ITEM NO.	PART NUMBER	DESCRIPTION	UNITS PER ASY.
	217697	Brake Assembly	1
1	216634	. Screw 10-24 x .50	1
2	216633	. Washer - Plain	1
3	217115	. Flag Assembly - Brake	1
4	214366	. Pin Assembly - Roller	1
5	93085	. Spring - Brake	1
6	91246	. Pin - Lever Pivot	1
7	91245	. Washer - Thrust	1

ITEM NO.	PART NUMBER	DESCRIPTION	UNITS PER ASY.
8	94144	. Pivot - Latch	1
9	217235	. Latch - Chain Brake	1
10	93082	. Pin - Band Anchor	1
11	93081	. Band - Brake	1
12	216687	. Screw - M5 x 14.25	1
13	92178	. Stop - Chain	1
14	92086	. Snubber - Brake Housing	1
15	217698	. Housing - Brake	1

Two (2) Brake Assemblies were used alternately by the factory. Identify which Brake you have prior to ordering replacement parts.

Fan Housing & Fuel Tank Assemblies

Figure 4

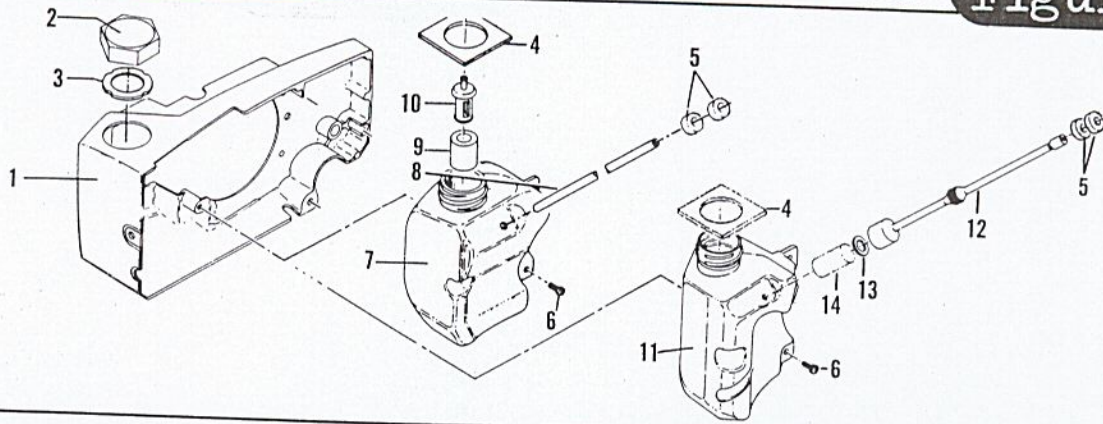

ITEM NO.	PART NUMBER	DESCRIPTION	UNITS PER ASY.
1	216154	Housing-Fan	1
2	216157	Cap-Fuel (vented)	1
3	94707	. Gasket-Fuel Cap	1
4	93251	Seal-Fuel Vent	1
5	92161	Seal-Air Box	1
6	120068	Screw-Pan Hd M4x12 (Sems)	2
7	-- --	① Tank Asy-Fuel	1

ITEM NO.	PART NUMBER	DESCRIPTION	UNITS PER ASY.
8	91994	Hose-Fuel	1
9	61159	Filter-Fuel Pickup	1
10	215714	Pickup Asy-Fuel	1
11	94901	① Tank Asy-Fuel	1
12	94899	. Hose Asy-Fuel	1
13	100440	.. Washer-5/16	1
14	63932	.. Filter-Fuel	1

① If saw was originally equipped with Item number 7, order individual parts as indicated. For replacement of Fuel Tank Assembly, order P/N 94901.

CARBURETOR ASSEMBLY

Figure 5

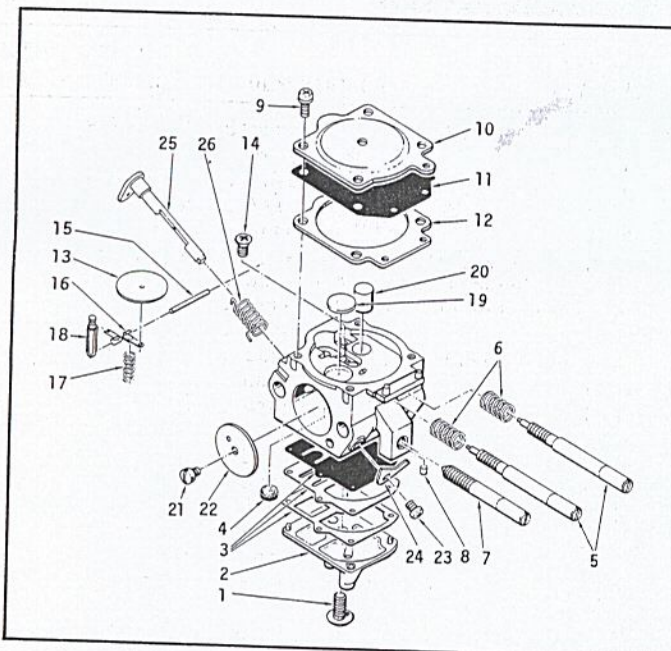

ITEM NO.	PART NUMBER	DESCRIPTION	UNITS PER ASY.
	95763	① Carburetor Asy. (Zama C-25)	
1	-- --	. Screw-Pump	1
2	214954	. Cover-Pump	1
3	-- --	② . Kit-Pump Diaphragm	1
4	-- --	② . Screen-Filter	1
5	-- --	② . Screw-Adjustment	2
6	-- --	② . Spring-Adjustment Screw	2
7	-- --	. Screw-Throttle Adjustment	1
8	-- --	. Piece-Friction	1
9	93945	. Screw-Diaphragm Cover	1
10	214945	. Cap	4
11	-- --	② . Diaphragm-Main	1
12	-- --	② . Gasket-Main	1
13	-- --	② . Disk	1
14	-- --	② . Screw Pin Lever	1
15	-- --	② . Pin-Arm	1
16	-- --	② . Arm-Needle Valve	1
17	-- --	② . Spring-Arm	1
18	-- --	② . Valve-Needle	1
19	-- --	. Plug-Welsh	1
20	-- --	② . Orifice-Main Fuel	1
21	-- --	. Screw-Plate	1
22	-- --	. Valve-Throttle	1
23	-- --	. Screw	1
24	-- --	. Lever-Throttle Adjustment	1
25	-- --	. Shaft Asy-Throttle	1
26	-- --	. Spring-Throttle Return	1

① One of three Carburetors used alternately on PM 610 models. Identify Carburetor before ordering service parts.

② Contained in Repair Kit, P/N 214959.

Figure 6

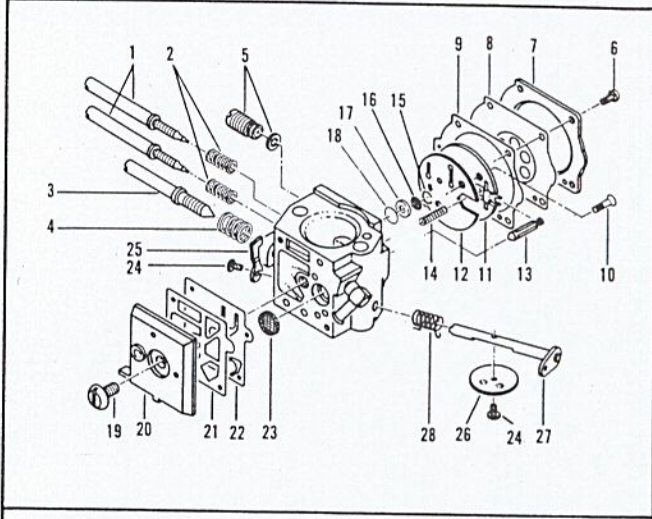
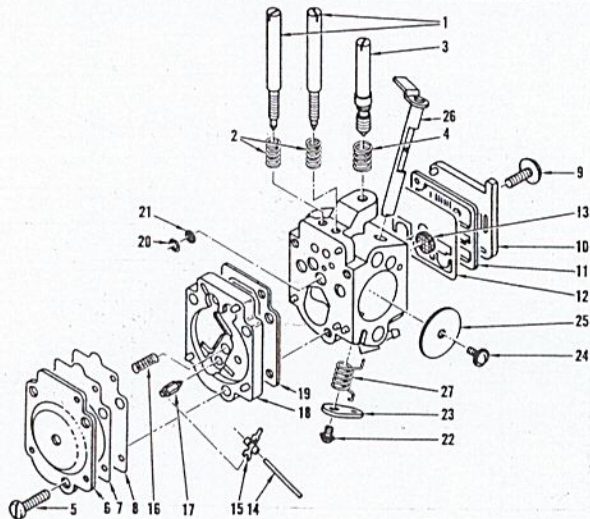

ITEM NO.	PART NUMBER	DESCRIPTION	UNITS PER ASY.
	95630	① Carburetor - Tillotson HK 19A (PM 610)	
1	94797	. Needle-High Speed/Idle	2
2	---	. Spring-Needle Adjustment	2
3	94798	. Spring-Idle Speed	1
4	---	. Spring-Idle Speed Screw	1
5	94789	. Screw-Diaphragm Cover	3
6	94788	. Cover-Diaphragm	1
7	94787	. Diaphragm	1
8	---	. Gasket-Diaphragm	1
9	94793	. Screw-Pump Cover	1
10	94792	. Cover-Fuel Pump	1
11	---	. Gasket-Fuel Pump	1
12	94794	. Diaphragm-Fuel Pump	1
13	---	. Screen-Fuel Strainer	1
14	---	. Pin-Inlet Lever	1
15	94800	. Lever-Inlet	1
16	---	. Spring-Inlet	1
17	94802	. Needle-Inlet	1
18	---	. Body-Module	1
19	---	. Gasket-Module Metering	1
20	94786	. Ring-Retaining	1
21	---	. Screen-Body Channel	1
22	94807	. Valve-Throttle	1
23	---	. Lever-Throttle	1
24	94811	. Screw-Throttle Shutter Ret	1
25	94810	. Shutter-Throttle	1
26	94808	. Shaft Asy-Throttle	1
27	94809	. Spring-Throttle Shaft Ret	1

ITEM NO.	PART NUMBER	DESCRIPTION	UNITS PER ASY.
	95763	① Carburetor - Walbro HDB-6A (PM 610)	
	95631	Carburetor - Walbro HDB-7A (PM 650 ONLY)	
1	---	. Needle-High Speed/Idle	2
2	---	. Spring-Needle Adjustment	2
3	94798	. Screw-Idle	1
4	---	. Spring-Idle Adjustment	1
5	---	. Governor Asy. (HDB-7A Only)	3
6	---	. Screw-Metering Cover	4
7	---	. Cover-Metering Diaphragm	1
8	---	. Diaphragm Asy-Metering	1
9	---	. Gasket-Metering Diaphragm	1
10	---	. Screw-Circuit Plate	1
11	---	. Plate Asy-Circuit	1
12	---	. Gasket-Circuit Plate	1
13	---	. Valve-Inlet Needle	1
14	---	. Spring-Metering Lever	1
15	---	. Ring-Screen Retaining	1
16	---	. Screen-Check Valve	1
17	---	. Retainer-Check Valve	1
18	---	. Valve-Check	1
19	---	. Screw-Fuel Pump Cover	1
20	---	. Cover-Fuel Pump	1
21	---	. Gasket-Fuel Pump	1
22	---	. Diaphragm-Fuel Pump	1
23	---	. Screen-Inlet	1
24	---	. Screw-Valve	2
25	---	. Stop-Throttle	1
26	---	. Valve-Throttle	1
27	---	. Shaft Asy-Throttle	1
28	---	. Spring Throttle Return	1

- ① One of three Carburetors used alternately on PM 610 models. Identify Carburetor before ordering service repair parts.
- ② Contained in Repair Kit, P/N 94813.
- ③ Contained in Major Repair Kit, P/N 217075.
- ④ Contained in Major Repair Kit, P/N 217077.

SPECIFICATIONS

Figure 7

Displacement PM 610/650/E.B. 3.7	3.7 cu. in. (60cc)
PM 605.	3.5 cu. in. (58cc)
Bore and Stroke PM 610/650/E.B. 3.7.	1.9 in. x 1.5 in. (4.7mm to 35mm)
PM 605	1.8 in. x 1.375 in. (40mm x 35mm)
Ignition	Electronic (C.D.I.)
Lamination Gap011 in. to .015 in. (.28mm to .38mm)
Timing	26 BTDC
Spark Plug Gap025 in. (.63mm)
Clutch Engagement Speed.	2800 to 3000 RPM
Idle Speed	1800 to 2000 RPM
Fuel Tank Capacity	17.3 Ounces (510cc)
Fuel Type.	Regular Grade Leaded or Unleaded Gas
Fuel/Oil Mixture	40:1 Using McCulloch Oil
	20:1 Using SAE Two Cycle
Oil Tank Capacity.	14.6 Ounces (430cc)
Main Bearings.	Needle and Ball
Connecting Rod Bearings.	Needle
Weight (Power Unit Only) All except PM 650	14.7 Lbs.
PM 650.	14.8 Lbs.

Figure 8 Bar/Chain/Chain Sharpening Tools

PART NUMBER	BAR DESCRIPTION	PART NUMBER	CHAIN DESCRIPTION	FILE PLATE PART NUMBER	ROUND FILE PART NUMBER
214237	Sprocket Tip 16"	218839-12	PMR370 GLX-60CL	219132	219161* 56698-23**
217025	Sprocket Tip 18"	218062-12	PMR370 GLX-66CL	219132	219161* 56698-23**
214238	Sprocket Tip 20"	218069-12	PMR370 GLX-70CL	219132	219161* 56698-23**

* 7/32" Round File Twin Pack
 ** 7/32" Round File 12-Pack

TOOLS & ACCESSORIES

Figure 9

<u>PART NUMBER</u>	<u>DESCRIPTION</u>	<u>PART NUMBER</u>	<u>DESCRIPTION</u>
215432	Pressure Test Tool	93770	Case Custom Lubricant 40:1
63137	Adaptor - Exhaust		Case Contains 48 cans 6 ounces
94415	Adaptor - Intake	95159	Allen Wrench - 5mm
84223	Kit - Piston Tools	69794	Locquic
95218	Air Filter - Felt	110083	R.T.V. Sealant
214221	Srench	94121	Kit - Carrying Case 20 Inches
214195	Gun-Lube (Disposable)	214203	. Scabbard 20 Inches
214194	Gun-Lube (Deluxe)	214208	Kit - Spike
85707	Case - Custom Lubricant 40:1		
	Case contains 24 cans 16 ounces		

Figure 10 SERVICE NOTES

PM 610 PISTON RINGS

Piston rings used on PM 610 Chain saws built before February 1984 are different than piston rings used on PM 610 units built since 1984. The rings are not interchangeable.

BEFORE FEBRUARY 1984

PM 610 Piston Rings (Thick)

If PM 610 being serviced is equipped with the thicker piston ring as illustrated in ACTUAL SIZE below, order p/n 94133.

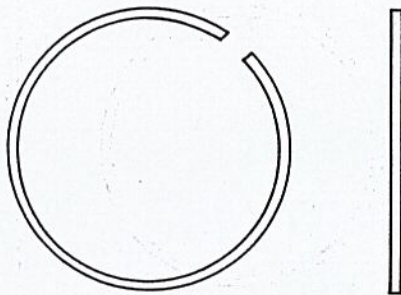

SINCE FEBRUARY 1984

PM 610 PISTON RINGS (Thin)

If PM 610 being serviced is equipped with the thinner piston ring as illustrated in ACTUAL SIZE below, order p/n 94132.

