

# ILLUSTRATED PARTS LIST

**THE PROFESSIONAL**

## PRO MAC 515 CHAIN SAW

MODELS	SERIAL NUMBER PREFIX
600117B	11-

McCulloch chain saws are identified by a model number (in this instance, 600117 ) followed by a suffix letter (A, B, C, etc.) stamped on the identification plate attached to the saw. Suffix letters denote variations in parts or assemblies in the manufacture of the saw.

Part numbers listed in this I.P.L. which have a suffix letter or letters following the description, indicate the part is used only on the model(s) identified by the letter or letters.

Part numbers and descriptions without suffix letter or letters apply to all versions of the chain saw model.

Part numbers which have one or more dots (.) preceding their descriptions may be ordered individually, but they are also included in the kit or assembly whose description begins directly above the dot(s).

Part numbers in this IPL which were not in the previous IPL covering these saws, are indicated by a dash (-) preceding the new part number.

The policy of McCulloch is one of continual improvement in design, manufacturing and engineering advancement wherever possible to assure still finer two-cycle power tools. Hence, specifications, equipment, colors, design and manufacturer's suggested list prices are subject to change without notice and McCulloch reserves the right to make such changes without prior notification or obligation to backfit or supply backfit components for units previously shipped from the factory.

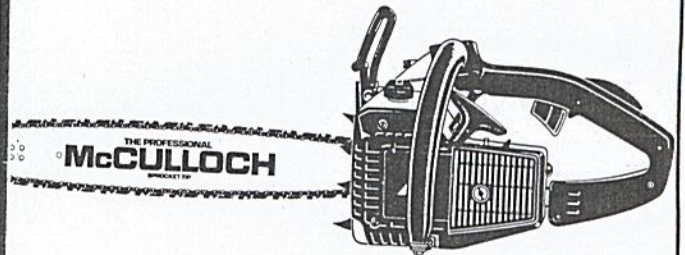

September 1982

- CONTENTS -

	Page
Figure 1. General.....	2
Figure 2. CHAIN BRAKE Assembly.....	4
Figure 3. Handle & Frame Assembly..	4
Figure 4. Starter Assembly.....	6
Figure 5. Powerhead Assembly.....	8
Figure 6. Carburetor Assembly.....	10
Tools & Accessories.....	7
Service Specifications...	7





# Pro Mac 515

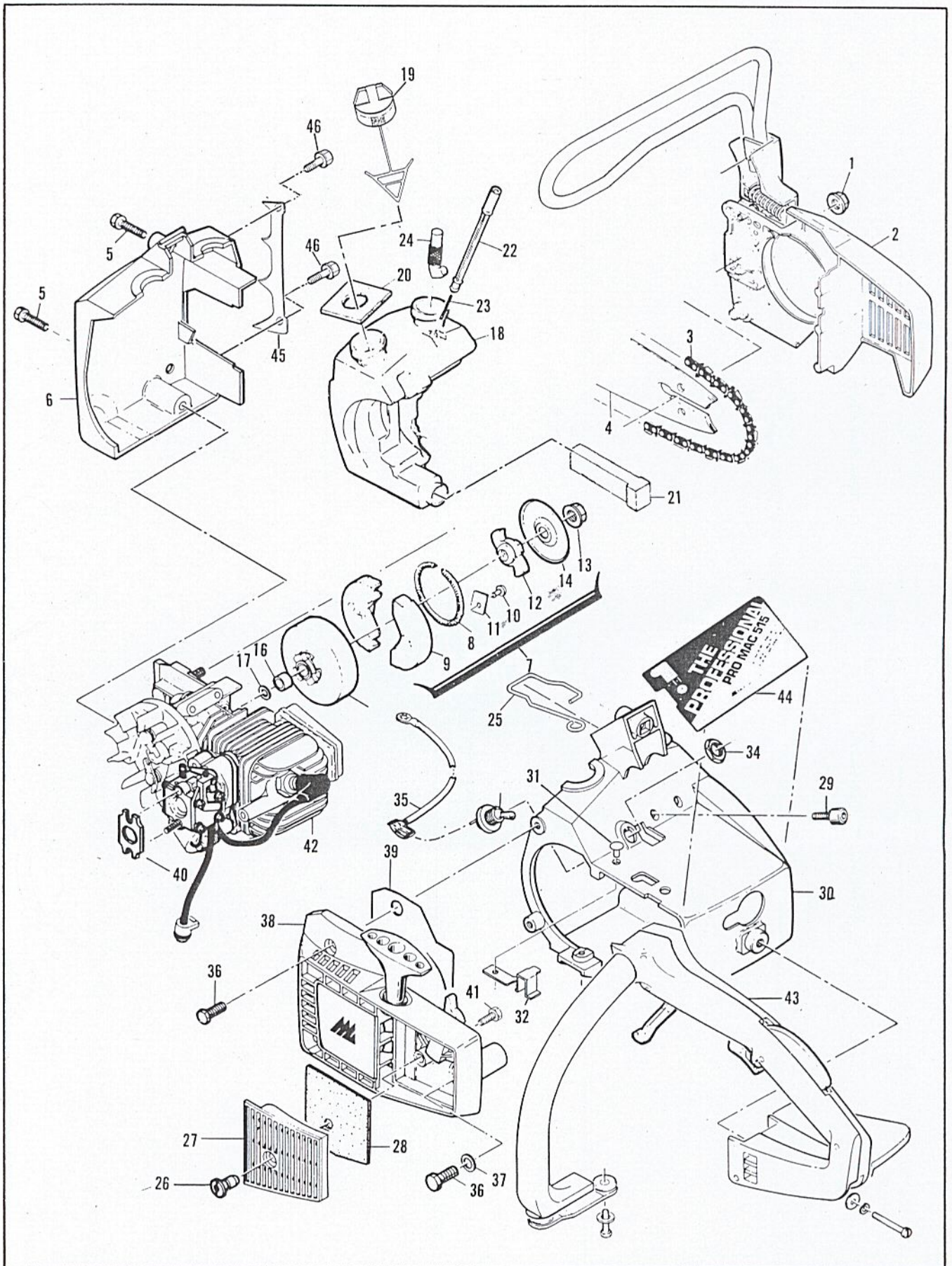

Figure 1. General



Figure 1. General

ITEM NO.	PART NUMBER	DESCRIPTION	UNITS PER ASY.
1	110676	Nut-Hx 1/4-28	1
2		CHAIN BRAKE Asy (Figure 2)	
3	214925N	Chain Asy	1
4	214236	Bar	1
5	110639	Screw-Hx hd 12-24 x 1	2
6	92863	Cover-Fuel & Oil tank	1
7	213278	Clutch Kit	1
8	93608	. Spring Asy	1
9	213276	. Shoe-Clutch	2
10	110957	. Rivet	2
11	85064	. Plate	2
12	94247	. Rotor Kit	1
13	94244	. . Nut-Clutch	1
14	94243	. . Plate-Dust	1
15	214390	Drum/Spkt/Brng Asy - .375P	1
16	91222	. Kit-Needle brng	1
17	215259	Washer-Sprocket	1
18	91454A	Tank Kit-Fuel & Oil	1
19	216070	. Cap-Fuel & Oil (unvented)	2
20	91148	. Seal-Fuel vent	1
21	84956	. Pickup-Fuel	1
22	213906	Piston-Pulse Oiler	1

ITEM NO.	PART NUMBER	DESCRIPTION	UNITS PER ASY.
23	83946	. Spring-Piston	1
24	85557	. Body-Oiler	1
25	93295	Rod-Oiler	1
26	89070	Nut-Air cleaner cover	1
27	89069	Cover-Air cleaner	1
28	92410	Filter-Air	1
29	216511	Screw-Skt 12-24 x 3/4	3
30	213822	Shroud/Latch Asy	1
31	111007	. Rivet	1
32	93912	. Spring-Throttle latch	1
33	92649	Kit-Ignition switch	1
34	104810	. Nut-Hx 15/32-32	1
35	69344	Wire Asy-Ignition	1
36	110953	Screw-Hx hd 12-24 x 5/8	3
37	110882	Washer	1
38		Starter Asy (Fig. 4)	
39	93236	Deflector-Air	1
40	94142	Gasket-Starter housing	1
41	102762	Screw-Hx hd 10-24 x 1/2	1
42		Powerhead Asy (Fig.5)	
43		Handle & Frame Asy (Fig. 3)	
44	216145	Plate-Name	1
45	91735	Kit-Spike	1
46	213046	. Screw Hx hd 10-24 x 1/2	2







Figure 2. CHAIN BRAKE Assembly

ITEM NO.	PART NUMBER	DESCRIPTION	UNITS PER ASY.
1	216439	Lever-Flag Brake	1
2	216256	Nut-Brake Handle	1
3	216541	Washer	1
4	216542	Washer-Lock	1
5	216276	Screw-BTN 1/4 - 20 x .81	1
6	216320	CHAIN BRAKE Asy	1
7	216540	. Screw-Fil 8-32 x 5/8	1
8	94709	. Band-Brake	1

ITEM NO.	PART NUMBER	DESCRIPTION	UNITS PER ASY.
9	215758	. Kit-Latch	1
10	-	. . Spring-Compression	1
11	93602	. Pivot-Latch	1
12	213907	. Pin-Roller	1
13	214368	. Bearing-Roller	1
14	213052	. Screw-Adjusting	1
15	110907	. Ring-Retaining	1
16	84929	. Nut-Bar Adjusting	1

Figure 3. Handle & Frame Assembly

ITEM NO.	PART NUMBER	DESCRIPTIONS	UNITS PER ASY.
1	213047	Screw - Skt 1/4-20 x 1-1/2	1
2	216392	Washer - Spring lock	1
3	100005	Washer	1
4	213048	Screw -Fil 1/4-20 x 1-3/4	1
5	105043	Washer - Spring lock	1
	94053	Kit - Handle and Frame	1
6	216388	. Screw - Hx 12-24 x 13/16	1
7	216538	. Screw - Pn 10-16 x 7/8	1
8	216537	. Screw-Pn 10-16 x 1-5/8	3
9	216536	. Washer	5
10	93057	. Spacer - Mount	3
11	110989	. Groimmet	3
12	93031	. Link Mount	1
13	216535	. Screw-Pn 8-16 x 5/8	3
14	93026	. Guard - Chain	1

ITEM NO.	PART NUMBER	DESCRIPTION	UNITS PER ASY.
15	94054	. Kit - Handle	1
16	216538	. . Screw - Pn 10-16 x 7/8	1
17	93030	. Insert - Handle	1
18	110976	. Screw - Pn 1/4 -14 x 1-3/4	1
19	94052	. Frame	1
20	110960	. Washer - Wavey	1
21	110936	. Retainer - Spring	2
22	216083	Trigger - Throttle	1
23	90606	Spring - Trigger	1
24	90615	Spring - Trigger release	1
25	91504	Release - Trigger	1
26	91171	Mount	1
27	105615	"O" Ring	1
28	91170	Mount Asy	1
29	105615	. "O" Ring	1



## Figure 4. Starter Assembly

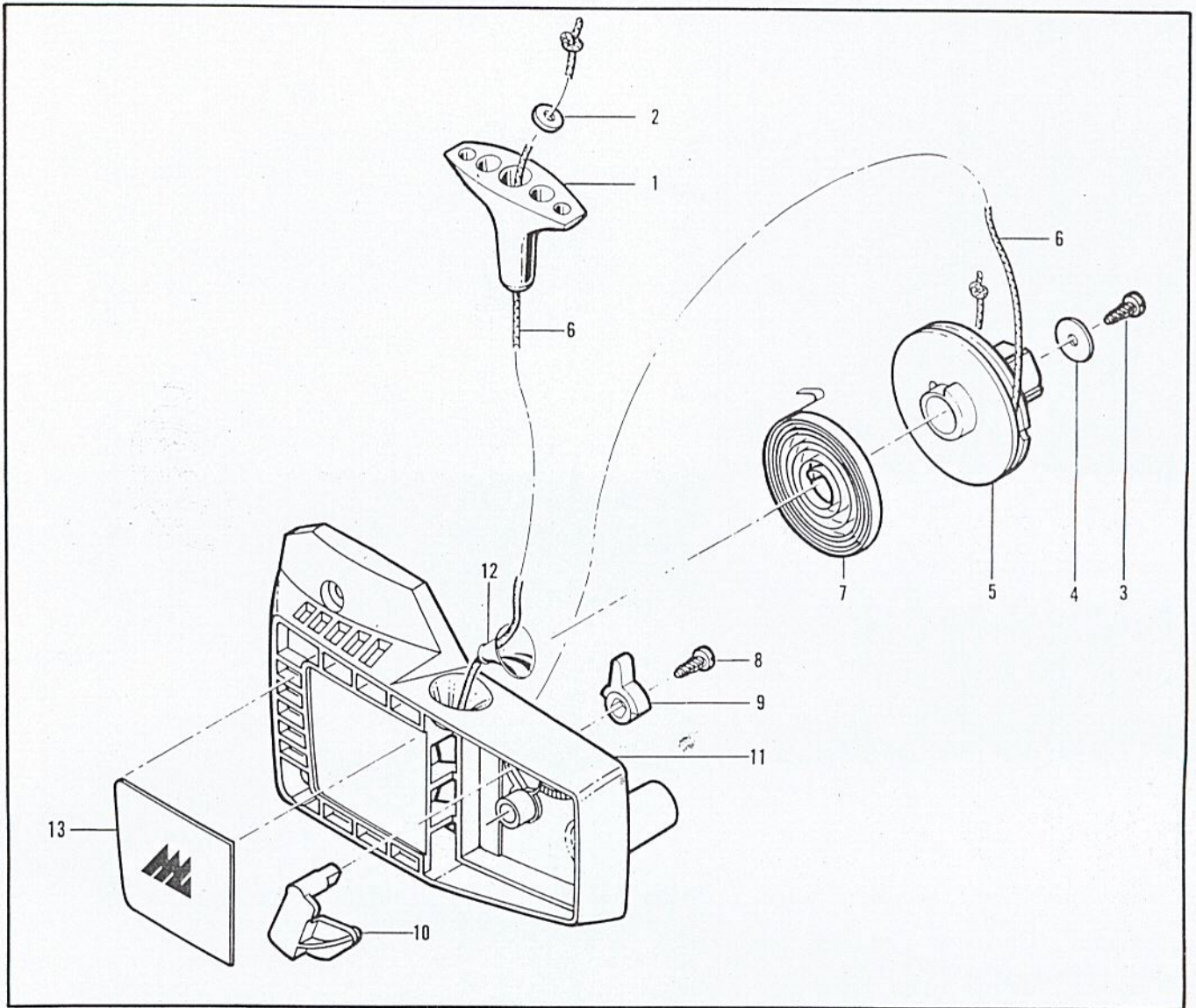

ITEM NO.	PART NUMBER	DESCRIPTION	UNITS PER ASY.
	213260	Starter Assembly	1
1	91255	. Kit - Starter handle	1
2	105490	. . Washer	1
3	110041	. Screw - Pan hd 8-32 x 1/2	1
4	68497	. Washer	1
5	213261	. Drum/Rope Assembly	1

ITEM NO.	PART NUMBER	DESCRIPTION	UNITS PER ASY.
6	83203	. . Rope-Starter	1
7	83078	. Spring-Rewind	1
8	110041	. Screw-Pan hd 8-32 x 1/2	1
9	91182	. Lever-Choke	1
10	91183	. Plate-Choke	1
11	94148	. Housing-Starter	1
12	67571	. . Guide-Rope	1
13	91570	. Plate	1



Tools & Accessories

PART NUMBER	DESCRIPTION
95169	Kit - Spark Arrester
91485	Wrench - Socket
85687	Wrench - Screwdriver
88755	Scrench
93090	Guide - Timing
90256	Kit - Tune-up
93285	Case - Carrying, 16"
92896	. Bar Guard 16"
214215	Guide - File
93900	Kit - Pressure Test
215432	Tool - Pressure Test
501334	Tester - Ignition

PART NUMBER	DESCRIPTION
214194	Lubri - Gun
85702	Lubricant - Custom, 6 oz. can
85703	Lubricant - Custom, 6 oz. cans 1-6 pack
67537	Loctite
69794	Locquic
110083	R.T.V. Sealant
214211	Kit - Tool Maintenance
216063	Key - Socket 5/32
216147	Key - Socket 1/8
216148	Key - Socket 3/16
216058	Key - Socket 9/64

Service Specifications

Displacement . . . . .	2.3 cu. in. (38 cc)	Timing . . . . .	26° B.T.D.C.
Bore and Stroke . . . . .	1.562 x 1.201 in. (39.68 x 30.51 mm)	Carburetor . . . . .	Diaphragm Type, 2 needle adjustment
Bearings . . . . .	Main: Needle Con Rod: Needle	Fuel Type . . . . .	Regular Grade, leaded
Intake System . . . . .	3rd Port, Piston Timed	Fuel - Oil Mixture . . . . .	40:1 w/McCulloch Oil
Fuel Tank Capacity . . . . .	11.8 fl. oz. (320 cc)	Fuel Filtering System . . . . .	Felt Fuel Filter
Chain Oiler Capacity . . . . .	3.2 fl. oz. (95 cc)	Air Filtering System . . . . .	Felt Air Filter
Clutch Engaging Speed. . . . .	3800 to 4100 R.P.M.	Piston Rings . . . . .	2 Cast Iron Compression Rings
Idle Speed . . . . .	2700 to 2900 R.P.M.	Spark Plug Gap . . . . .	.025 in. (.635 mm)
Ignition . . . . .	Magneto	Weight (Power Unit Only)	10.6 lbs. (4.8 kg)
Breaker Point Gap . . . . .	.018" (.457 mm)		
Lamination Gap . . . . .	.008 to .012" (.203 to .304 mm)		



# Pro Mac 515

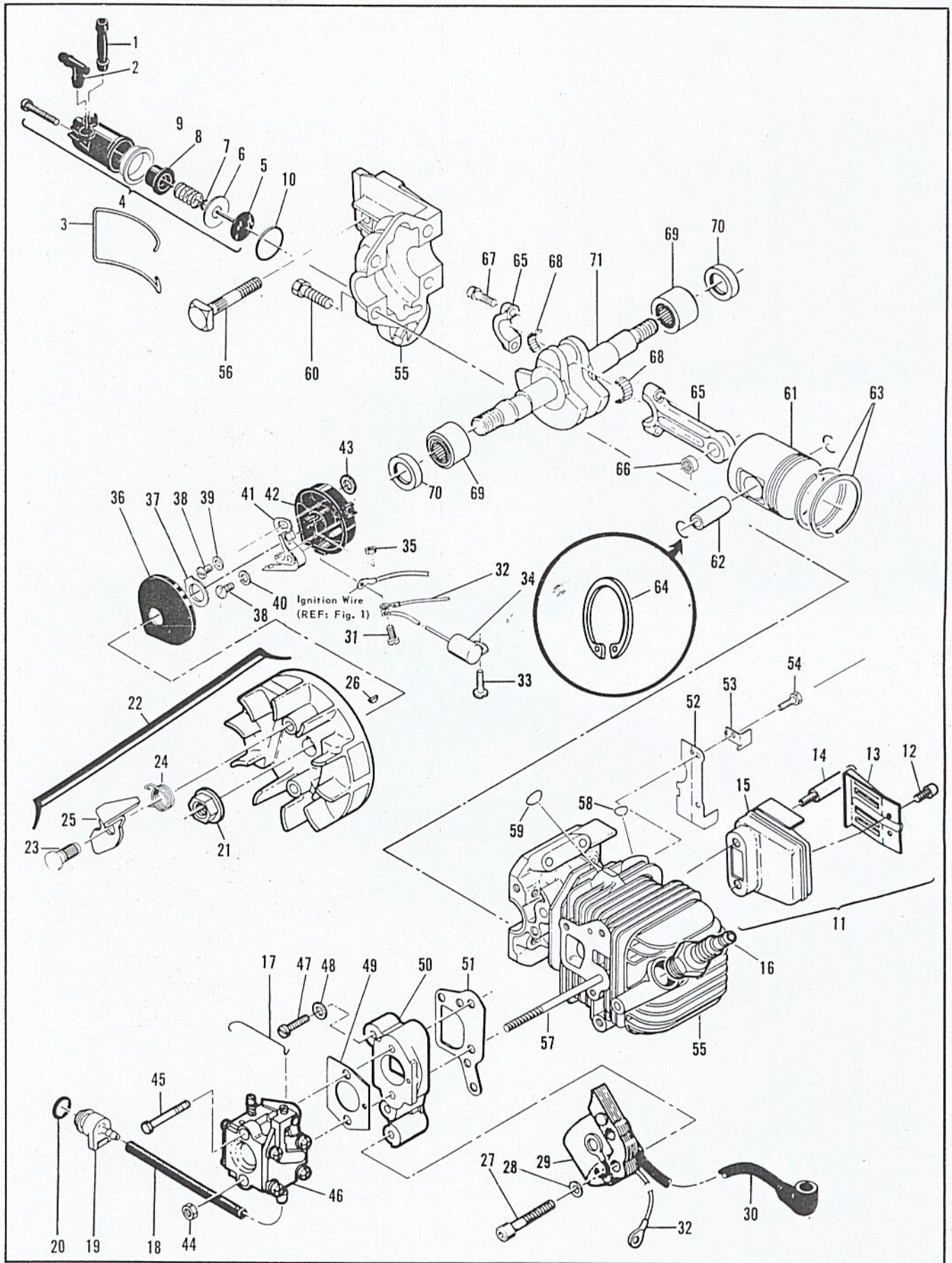

Figure 5. Powerhead Assembly



Figure 5. Powerhead Assembly

ITEM NO.	PART NUMBER	DESCRIPTION	UNITS PER ASY.	ITEM NO.	PART NUMBER	DESCRIPTION	UNITS PER ASY.
1	83898	Connector - Outlet	1	36	67841	Cover - Breaker box	1
2	84613	Connector - Pump	1	37	69323	Seal - Breaker box	1
3	83896	Bail - Mounting	1	38	213032	Screw - Hx hd 8-32 x 1/2	2
4	215739	Pump Assembly - Oiler	1	39	69322	Washer - Hard #8	1
	216426	Repair Kit - Oil Pump	1	40	105976	Washer - #8 Plain	1
5	-	. Piston Assembly	1	41	88811	Breaker Assembly	1
6	-	. Piston Ring	1	42	92054	Kit - Breaker box	1
7	-	. "O" Ring	1	43	92037	. Washer	1
8	-	. Sleeve	1	44	105367	Nut - Hx 10-24	1
9	-	. Eyelet	1	45	110614	Screw - Hx hd 10-24 x 2-3/8	1
10	110653	"O" Ring	1	46		Carburetor Assembly (Figure 6)	1
11	215411	Kit - Muffler	1	47	110652	Screw - Pan hd 8-32 x 1	1
12	110681	. Screw - Skt hd 10-24 x 1/4	2	48	100080	Washer - #8	1
13	92961	. Deflector - Exhaust	1	49	89057	Gasket - Carburetor	1
14	213327	. Screw - Special	2	50	214352	Insulator	1
15	-	. Body - Cover	1	51	89054	Gasket - Insulator	1
16	63432	Spark Plug	1	52	89648A	Shield	1
17	89060	Rod - Throttle	1	53	93353	Deflector - Sawdust	1
18	89059	Hose - Fuel	1	54	110674	Screw - Hx hd 10-24 x 1/2 s/t	2
19	90660	Adapter - Fuel hose	1	55	214156	Cylinder/C'case Assembly	1
20	110908	"O" Ring	1	56	83856	. Bolt - Bar mounting	1
21*	110961	Nut - Hx 5/16-24	1	57	94143	. Stud	1
22	94737	Flywheel/Pawl Assembly	1	58	110914	. Plug - Cup	2
23	68796	. Pin - Pawl	2	59	111024	. Plug - Cup	2
24	67814	. Spring - Pawl	2	60	216512	Screw - Skt 12-24 x 1	4
25	94493	. Pawl - Starter	2	61	94661	Piston Assembly	1
26	102164	Key - Woodruff	1	62	92836	. Pin - Piston	1
27	213050	Screw - Skt 8-32 x 1-5/8	2	63	91703	. Ring Set - Piston	1
28	100080	Washer - #8	2	64	111026	. Ring - Snap	2
29	84957	Coil & Lamination	1	65	94135	Connecting Rod Assembly	1
30	215351	. Wire Assembly - Spark plug	1	66	110984	. Bearing - Needle	1
31	110364	Screw - Pan hd 6-32 x 3/4	1	67	94654	. Screw - Connecting rod	2
32	69344	Wire Assembly - Coil	1	68	68095	. Roller - Needle (set of 20)	1
33	110041	Screw - Pan hd 8-32 x 1/2	1	69	93763	Sleeve Assembly - Bearing	2
34	85358	Condenser	1	70	83859	. Seal - Oil	2
35	100035	Nut - Hx 6-32	1	71	91932	Crankshaft	1

\* Flywheel nut torque should be 190 to 200 pound x inches (21.5 to 22.6 N.m)

① Eyelet is only available in Oil Pump Repair Kit



# Pro Mac 515

## Figure 6. Carburetor Assembly

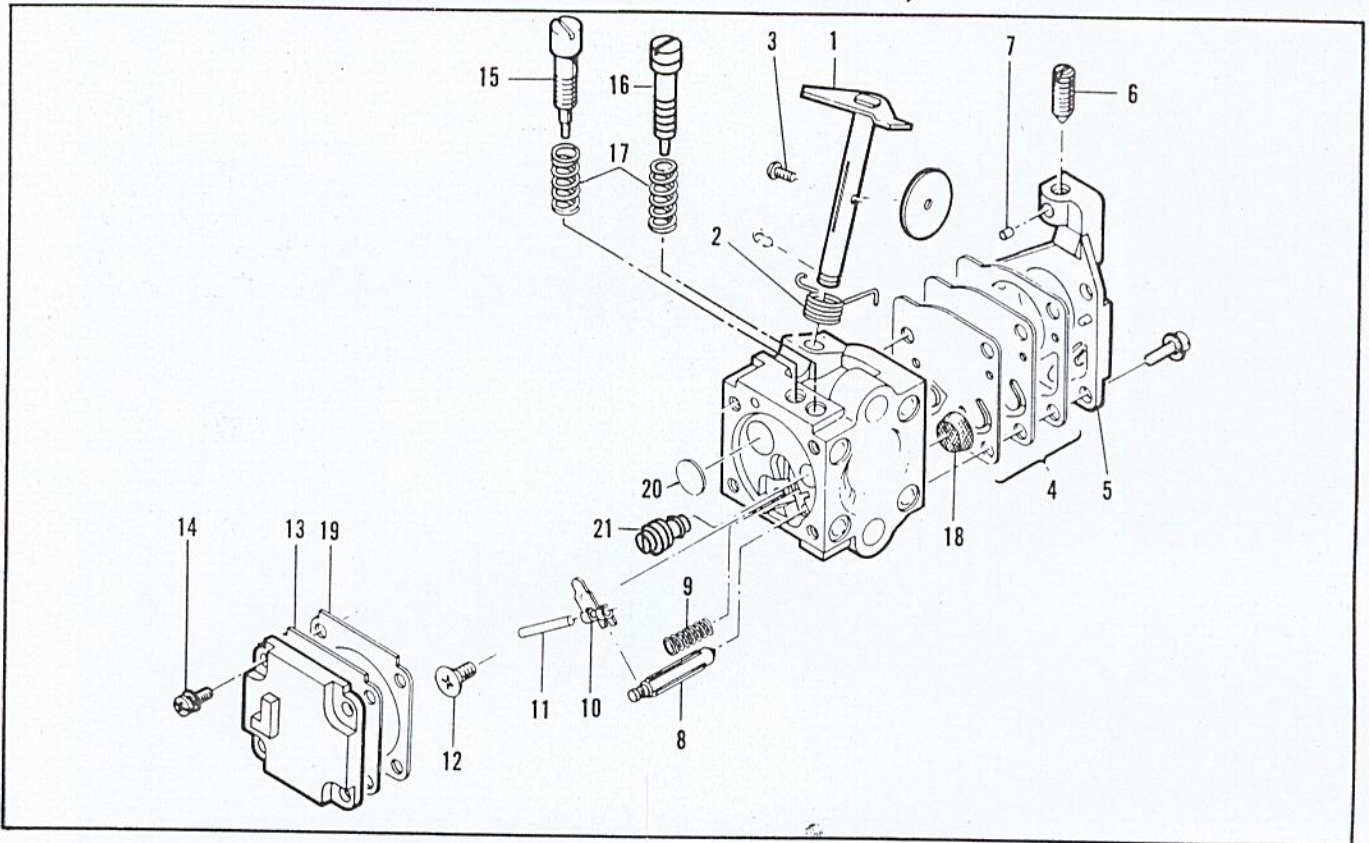

ITEM NO.	PART NUMBER	DESCRIPTION	UNITS PER ASY.
	93766	Carburetor Asy (Zama)	1
1	- -	. Shaft Asy-Throttle	1
2	- -	. Spring-Throttle return	1
3	- -	. Screw-Plate (m3)*	1
4	91824②①	. Kit-Diaphragm & Gaskets	1
5	- -	. Cover Asy-Pump	1
6	- -	. Screw-Idle speed	1
7	- -	. Insert-Friction	1
8	91810 ①	. Needle-Inlet	1
9	91811 ①	. Spring-Lever	1
10	91812 ①	. Lever-Inlet needle	1
11	91813 ①	. Pin-lever	1

ITEM NO.	PART NUMBER	DESCRIPTION	UNITS PER ASY.
12	91814 ①	. Screw-Lever pin (m3)*	1
13	91815②①	. Diaphragm Asy-Metering	1
14	- - ①	. Screw-Diaphragm cover (m3)*	4
15	91818 ③	. Needle-Idle mixture	1
16	94033 ③	. Needle-High speed	1
17	91819 ③	. Spring-Needle	2
18	91820 ①	. Screen-Filter	1
19	91821②①	. Gasket-Metering diaphragm	1
20	92097 ①	. Welch Plug	1
21	93950 ①	. Orifice-Main fuel	1

① Contained in Repair Kit, P/N 216732.

② Contained in Gasket/Diaphragm Kit, P/N 216733.

③ Contained in Needle Kit, P/N 216803.

NOTE: Items not listed with part numbers are shown for identification and disassembly sequence purposes only. They are NOT available as service parts.