

ILLUSTRATED PARTS LIST

MODELS	SERIAL NUMBER PREFIX	MODELS	SERIAL NUMBER PREFIX
600112B	11-	600112D	11-

McCulloch chain saws are identified by a model number (in this instance, 600112) followed by a suffix letter (A, B, C, etc.) stamped on the identification plate attached to the saw. Suffix letters denote variations in parts or assemblies in the manufacture of the saw.

Part numbers listed in this I.P.L. which have a suffix letter or letters following the description, indicate the part is used only on the model(s) identified by the letter or letters.

Part numbers and descriptions without suffix letter or letters apply to all versions of the chain saw model.

Part numbers which have one or more dots (.) preceding their descriptions may be ordered individually, but they are also included in the kit or assembly whose description begins directly above the dot(s).

Part numbers in this IPL which were not in the previous IPL covering these saws, are indicated by a dash (-) preceding the new part number.

The policy of McCulloch is one of continual improvement in design, manufacturing and engineering advancement wherever possible to assure still finer two-cycle power tools. Hence, specifications, equipment, colors, design and manufacturer's suggested list prices are subject to change without notice and McCulloch reserves the right to make such changes without prior notification or obligation to backfit or supply backfit components for units previously shipped from the factory.

PRO MAC 155 PRO MAC 165 CHAIN SAW

PRO MAC™ 155

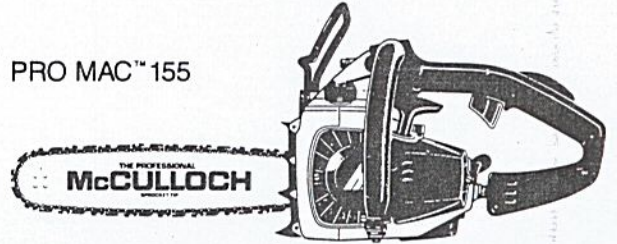

PRO MAC™ 165

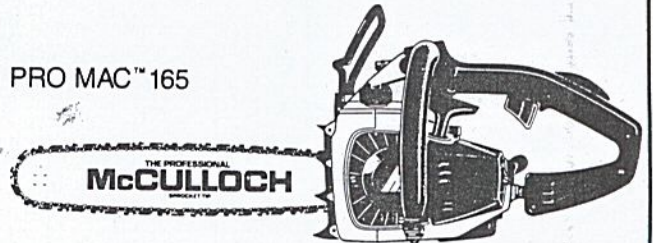

Sept. 1982

- CONTENTS -

	Page
Figure 1. General	2
Figure 2. Carburetor Assembly	4
Figure 3. Handle/Frame Assembly	5
Figure 4. Powerhead Assembly	6
Figure 5. CHAIN BRAKE Assembly	8
Bar & Chain Combinations	3
Tools & Accessories	8
Service Specifications	3

McCULLOCH
 Division of Black & Decker (U.S.) Inc.

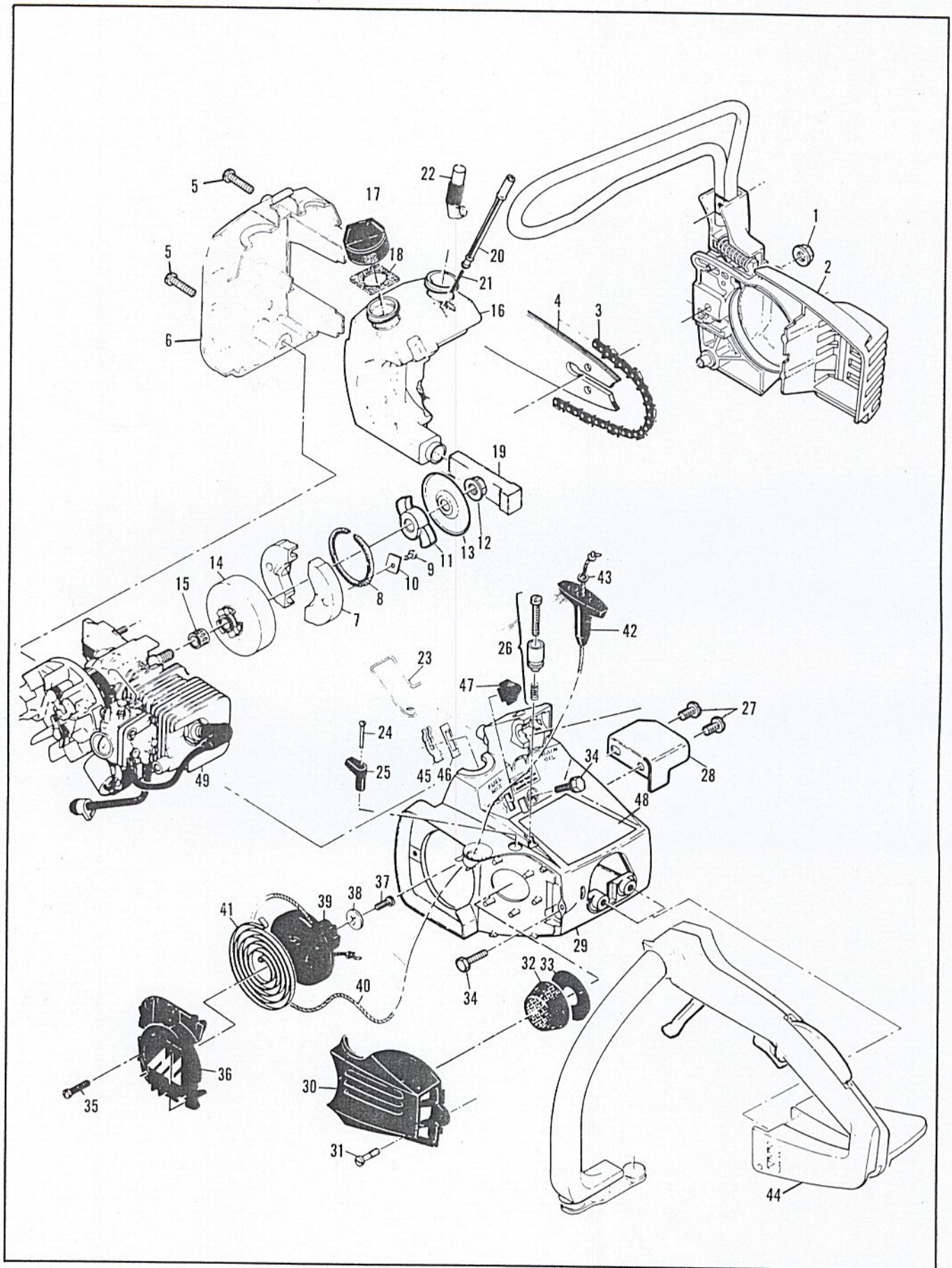

Figure 1. General.

Figure 1. General

ITEM NO.	PART NUMBER	DESCRIPTION	UNITS PER ASY.
1	216539	Nut - Hx 1/4-28	1
2	- -	CHAIN BRAKE Asy (Fig. 5)	2
3	- -	Chain Asy (See below)	1
4	- -	Bar (See below)	1
5	216512	Screw - Skt hd 12-24 x 1	1
6	214642	Cover - Fuel & Oil Tank	2
7	213278	Kit - Clutch	2
8	93608	. Spring Assembly	1
9	110957	. Rivet	1
10	85064	. Plate	1
11	94247	. Kit - Rotor	1
12	94244	. . Nut - Clutch	1
13	94243	. . Plate - Dust	1
14	214390	Drum/Spkt/Brng Assembly	1
15	91222	. Kit - Needle Bearing	1
16	91454A	Kit - Fuel & Oil Tank	1
17	216070	. Cap - Fuel & Oil (unvented)	2
18	91148	. Seal - Fuel Vent	1
19	84956	. Pickup - Fuel	1
20	213906	. Piston - Manual oiler	1
21	83946	. Spring - Piston	1
22	85557	. Body - Oiler	1
23	90706	Rod - Manual Oiler	1
24	216532	Screw - Oval hd 4-40 x 1	1
25	83870	Knob - Choke	1

ITEM NO.	PART NUMBER	DESCRIPTION	UNITS PER ASY.
26	- -	Throttle Latch Asy (Fig. 2)	2
27	110807	Screw - Pan hd 8-32 x 5/16	1
28	93290	Deflector - Sawdust	1
29	214987	Shroud	1
30	91853	Cover - Air Cleaner	1
31	91796	. Screw - Air Cleaner	1
32	91460	Filter - Air	1
33	84918	Washer - Air Seal	3
34	216511	Screw - Skt hd 12-24 x 5/8	3
35	216389	Screw - Hx hd 8-32 x 1/2	1
36	90425	Cover - Starter	1
37	110041	Screw - Pan hd 8-32 x 1/2	1
38	68497	Washer - Special	1
39	213261	Drum/Rope Assembly	1
40	83203	. Rope - Starter	1
41	83078	Spring - Rewind	1
42	91255	Kit - Starter Handle	1
43	216531	. Washer - Starter Handle	1
44	- -	Handle Assembly (Fig. 3)	
45	83935	Contact - Switch	1
46	83936	Protector - Switch	1
47	83934	Button - Switch	1
48	216072	Plate - Name (MAC 165)	1
48	216074	Plate - Name (MAC 155)	1
49	- -	Powerhead Assembly (Fig. 4)	

Bar & Chain Combinations

PART NUMBER	DESCRIPTION
214234	Bar-12" Mini Pro (Sprocket tip)
90631	Bar-12" Mini Mac
90770	Bar-12" Mac 6
214921N	Chain-12" MP 370 GL

PART NUMBER	DESCRIPTION
214235	Bar-14" Mini Pro (Sprocket tip)
91730	Bar-14" Mini Mac
90770	Bar-14" Mac 6
214919N	Chain-14" MP 370 GL

Service Specifications

Displacement	2.0 cu. in.
Bore and Stroke	1.430 x 1.201 in. (36.5 x 30.5 mm)
Bearings	Main: Needle Conn. Rod: Needle
Intake System	3rd Port, Piston Timed
Fuel Tank Capacity	10.8 fl. oz. (320 cc)
Chain Oiler Capacity	3.2 fl. oz. (95 cc)
Clutch Engaging Speed	3800 to 4200 rpm
Idle Speed	2700 to 2900 rpm
Ignition	Magneto

Carburetor	Diaphragm Type, 2 needle
Fuel Type	Regular grade, leaded
Fuel/Oil Mixture	40:1 w/ McCulloch Oil
Filter System - Fuel	Felt Fuel Filter
Filter System - Air	Flocked Screen Filter
Lamination Gap	.008 to .012" (.203 to .304 mm)
Breaker Point Gap	.018" (.457 mm)
Timing	26° B.T.D.C.
Piston Rings	2 Cast Iron Compression
Weight (w/ bar & chain):	
PRO MAC 155	9.6 lbs. (4.3 kg)
PRO MAC 165	9.7 lbs. (4.4 kg)

Figure 2. Carburetor Assembly

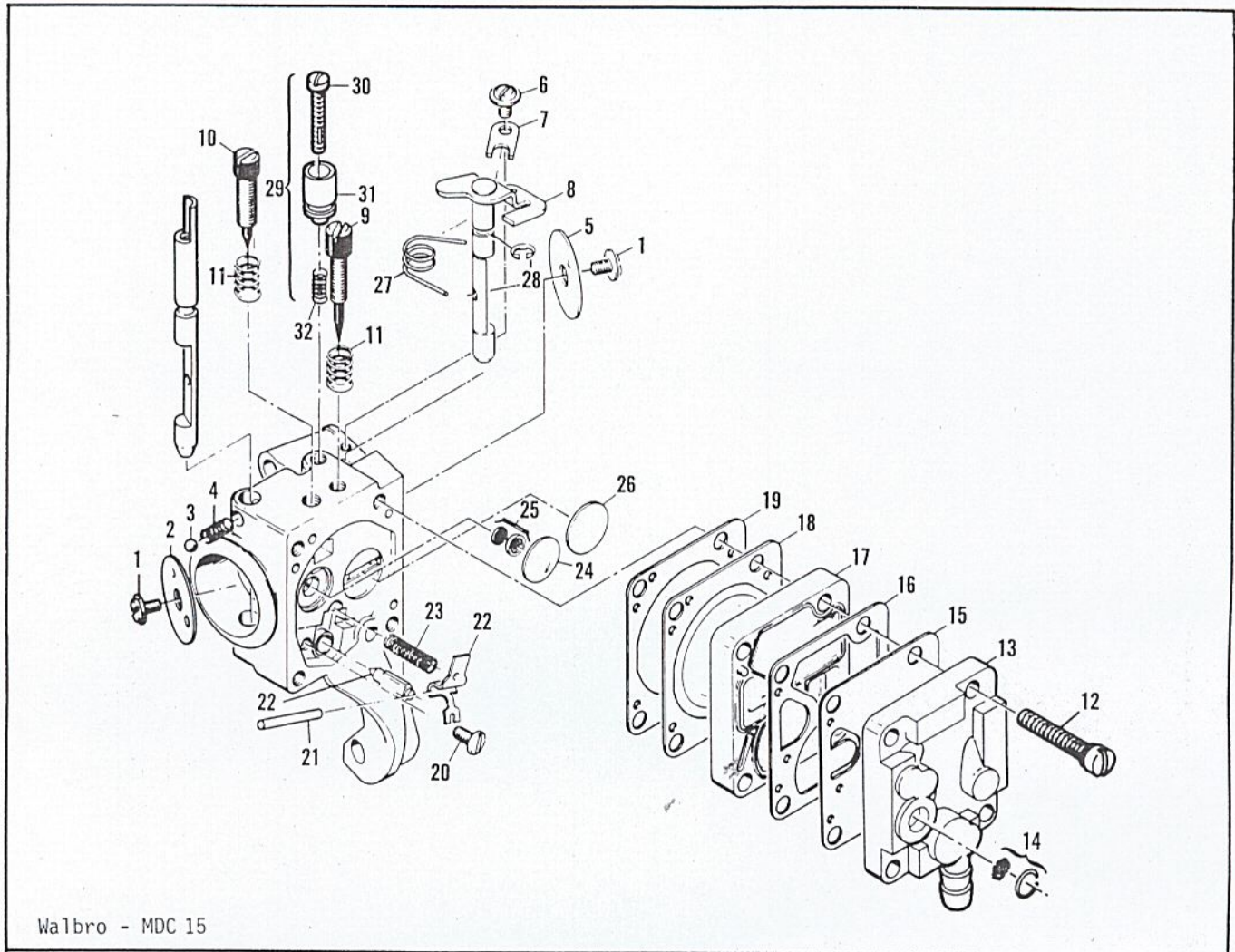

Walbro - MDC 15

ITEM NO.	PART NUMBER	DESCRIPTION	UNITS PER ASY.
	214082	Carburetor Asy - Walbro MDC 15	1
1	-	. Screw - Plate	2
2	-	. Plate - Choke	1
3	-	. Ball - Choke friction	1
4	-	. Spring - Choke friction	1
5	-	. Plate - Throttle	1
6	-	. Screw - Clip	1
7	-	. Clip - Throttle shaft	1
8	-	. Shaft Asy - Throttle	1
9	86446 ③	. Needle - Idle	1
10	86447 ③	. Needle - High speed	1
11	67502 ③	. Spring - Needle	2
12	-	. Screw Asy - Body	4
13	-	. Cover Asy - Pump	1
14	85629 ①	. Kit - Vent screen	1
15	68563 ②①	. Diaphragm - Fuel pump	1
16	85035 ②①	. Gasket - Pump diaphragm	1

ITEM NO.	PART NUMBER	DESCRIPTION	UNITS PER ASY.
17	-	. Body - Fuel pump	1
18	85036 ②①	. Diaphragm - Metering	1
19	85034 ②①	. Gasket - Diaphragm	1
20	67500 ①	. Screw - Lever pin	1
21	67508 ①	. Pin - Lever	1
22	85059 ①	. Kit - Needle & Lever	1
23	68567 ①	. Spring - Lever	1
24	68559 ①	. Plug - Welsh 7/16	1
25	83758 ①	. Kit - Check valve	1
26	68560 ①	. Plug - Welsh 1/2	1
27	-	. Spring - Throttle return	1
28	-	. Ring - Retaining	1
29	93437	Latch Asy - Throttle	1
30	-	. Screw - Long lock	1
31	-	. Latch - Throttle	1
32	-	. Spring - Compression	1

① Contained in Repair Kit, P/N 216731

② Contained in Repair Kit, P/N 216727

③ Contained in Repair Kit, P/N 216725

NOTE: Items not listed with part numbers are shown for identification and disassembly sequence purposes only. They are NOT available as service parts.

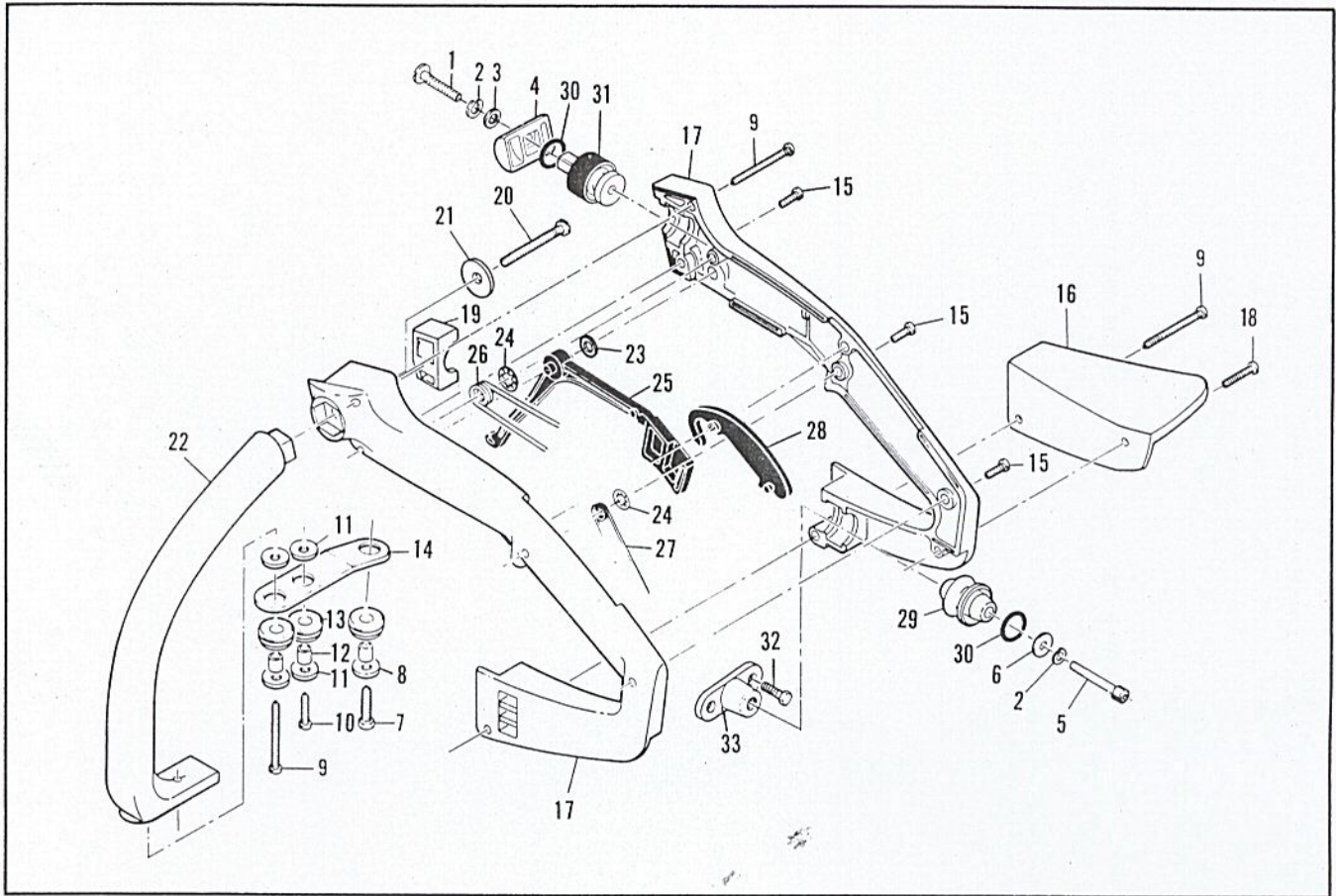

Figure 3. Handle & Frame Assembly

ITEM NO.	PART NUMBER	DESCRIPTION	UNITS PER ASY.
1	213047	Screw -Skt hd 1/4-20 x 1-1/2	1
2	216533	Washer - Spring Lock	2
3	216534	Washer	1
4	91168	Fitting - Shroud	1
5	213048	Screw - Skt hd 1/4-20 x 1 3/4	1
6	111027	Washer	1
	93060A	Handle/Frame Asy	
7	216388	. Screw - Hx 12-24 x 13/16	1
8	216536	. Washer	1
9	216537	. Screw - Pn 10-16 x 1	3
10	216538	. Screw - Pn 10-16 x 3/4	1
11	216536	. Washer	4
12	93057	. Spacer - Mount	3
13	110989	. Grommet	3
14	93031	. Link Mount	1
15	216535	. Screw - Pn 8-16 x 5/8	3
16	93026	. Guard - Chain	1
17	94054	. Kit - Handle	1

ITEM NO.	PART NUMBER	DESCRIPTION	UNITS PER ASY.
18	216538	. . Screw - Pn 10-16 x 3/4	1
19	93030	. Insert - Handle	1
20	110976	. Screw - Pn 1/4-14 x 1-3/4	1
21	111027	. Washer	1
22	94052	. Frame	1
23	110960	. Washer - Wavey	1
24	110936	. Retainer - Spring	2
25	216083	Trigger - Throttle	1
26	90606	Spring - Trigger	1
27	90615	Spring - Trigger Release	1
28	91504	Release - Trigger	1
29	91171	Mount	1
30	105615	"O" Ring	2
31	91170	Mount	1
32	216390	Screw - Hx Hd 12-24 x 5/8	2
33	90436	Adaptor - Rear	1

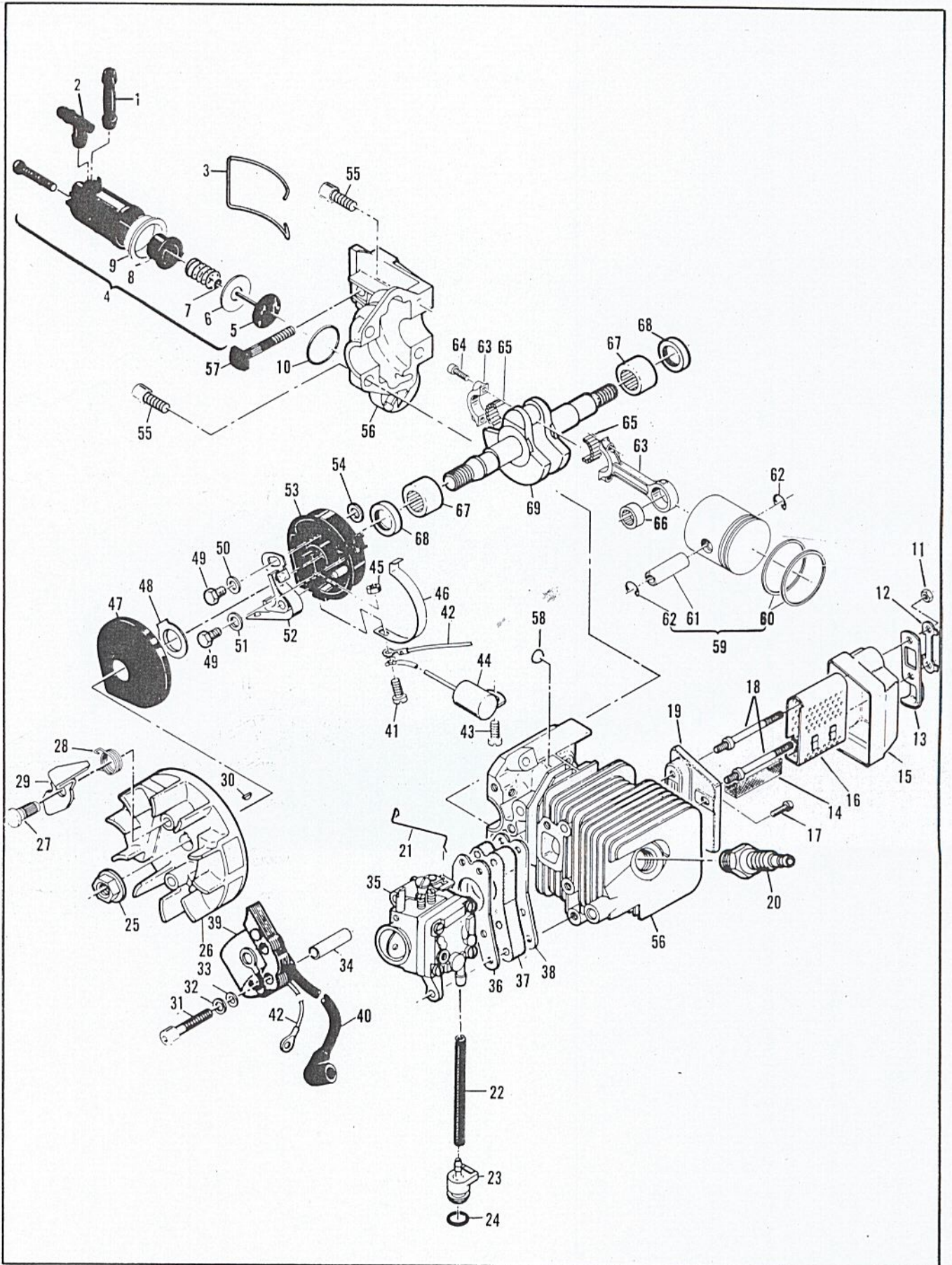

Figure 4. Powerhead Assembly.

Figure 4. Powerhead Assembly

ITEM NO.	PART NUMBER	DESCRIPTION	UNITS PER ASY.	ITEM NO.	PART NUMBER	DESCRIPTION	UNITS PER ASY.
1	83898	Connector-Outlet	1	36	68197	Gasket-Carburetor	1
2	84613	Connector-Pump	1	37	214349	Insulator-Carburetor	1
3	83896	Bail-Mounting	1	38	90714	Gasket-Insulator	1
4	215739	Pump Assembly-Oiler	1	39	84957	Coil & Lamination Assembly	1
	216426	Repair Kit-Oil Pump		40	215351	. Wire Assembly-Spark Plug	1
5	-	. Piston Assembly	1	41	110364	Screw-Pan hd 6-32 x 5/8	1
6	-	. Piston Ring	1	42	69344	Wire Assembly-Coil	1
7	-	. "O" Ring	1	43	110041	Screw-Pan hd 8-32 x 1/2 s/t	1
8	-	. Sleeve	1	44	85358	Condenser	1
9	-	① . Eyelet	1	45	100038	Nut-Hx 6-32	1
10	110653	"O" Ring	1	46	84502	Connector-Stop Switch	1
11	215871	Nut-Muffler	2	47	67841	Cover-Breaker Box	1
12	215471	Plate-Lock	1	48	69323	Seal-Breaker Box	1
13	215472	Deflector-Exhaust	1	49	110969	Screw-Hex hd 8-32 x 1/2	2
14	215872	Screen-Spark Arrester	1	50	69322	Washer-Special	1
15	215774	Cover	1	51	105976	Washer-#8	1
16	215776	Baffle	1	52	88811	Breaker Assembly	1
17	213369	Screw	1	53	84505A	Kit-Breaker Box	1
18	215757	Bolt-Shoulder	2	54	92037	. Washer	1
19	215773	Base	1	55	216512	Screw-Skt hd 12-24 x 1	4
20	214406	Spark Plug	1	56	214164	Kit-Cylinder	1
21	216039	Rod-Throttle	1	57	83856	. Bolt-Bar mounting	1
22	89059	Hose-Fuel	1	58	110914	. Plug-Cup	4
23	90660	Adaptor-Fuel Hose	1	59	216713	Piston Assembly	1
24	110908	"O" Ring	1	60	216705	. Set-Piston Rings	1
25	110961	Nut-Hex 5/16-24	1	61	92836	. Pin-Piston	1
26	94737	Flywheel/Pawl Assembly	1	62	111026	. Ring-Snap	2
27	68796	. Pin-Pawl	2	63	94135	Connecting Rod Assembly	1
28	67814	. Spring-Pawl	2	64	94654	. Screw-Connecting Rod	2
29	94493	. Pawl-Starter	2	65	68095	. Roller-Needle (set of 20)	1
30	102164	Key-Woodruff	1	66	110984	. Bearing-Needle	1
31	213050	Screw-Skt hd 8-32 x 1-3/4	3	67	213282	Bearing-Crankshaft	2
32	105976	Washer-#8	3	68	83859	. Seal-Crankshaft	1
33	67177	Washer-Insulating	3	69	91932	Crankshaft	1
34	68198	Tube-Insulating	3				
35	-	Carburetor Assembly (Fig. 2)					

① Eyelet is ONLY available in Oil Pump Repair Kit.

Figure 5. CHAIN BRAKE Assembly

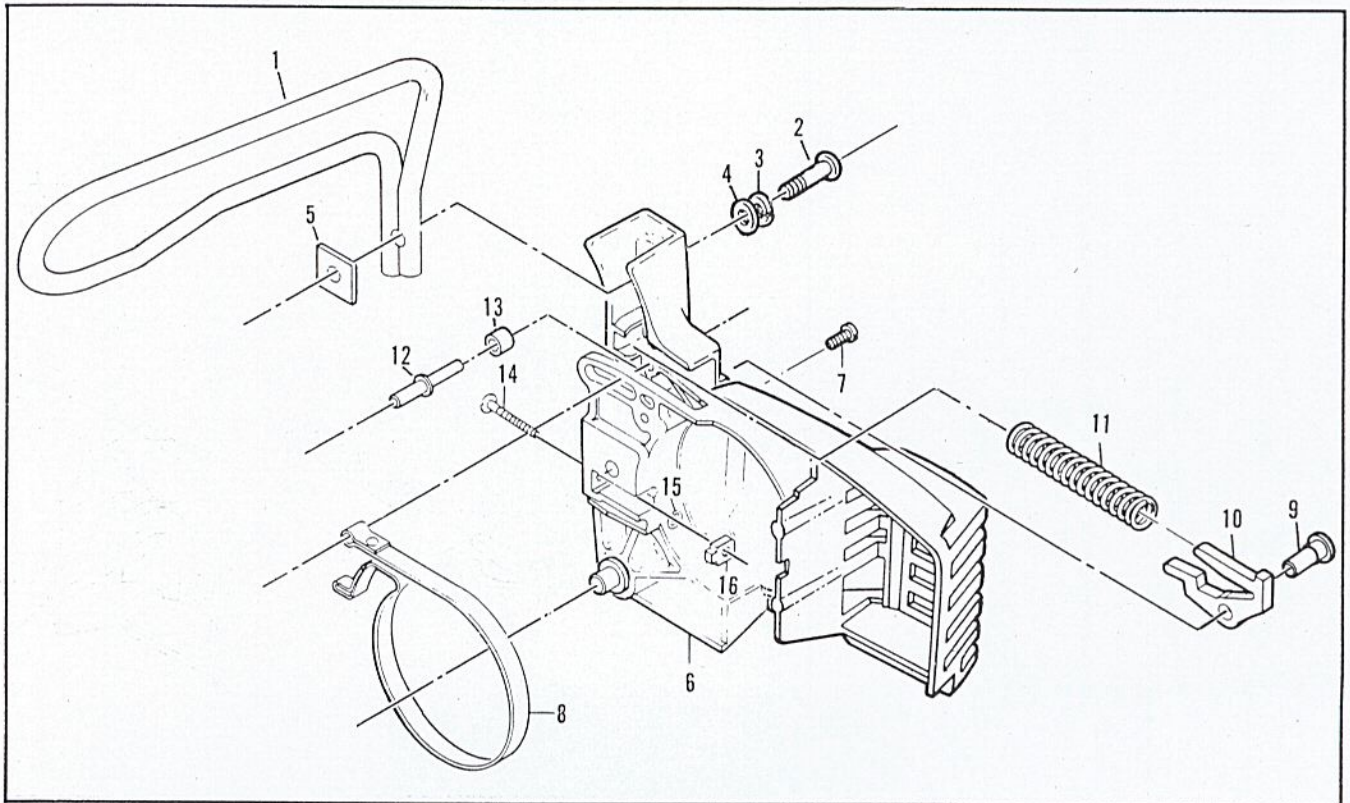

ITEM NO.	PART NUMBER	DESCRIPTION	UNITS PER ASY.
1	216439	Lever - Flag Brake	1
2	216276	Screw - Btn 1/4-20 x 13/16	1
3	216542	Washer - Lock	1
4	216541	Washer - P1	1
5	216256	Nut - Brake Handle	1
6	216555	Chain Brake Asy	1
7	216540	Screw - Fil hd 8-32 x 5/8	1
8	94709	Band - Brake	1

ITEM NO.	PART NUMBER	DESCRIPTION	UNITS PER ASY.
9	93602	Pivot - Latch	1
10	215758	Kit - Latch	1
11	----	Spring - Compression	1
12	213907	Pin - Roller	1
13	214368	Bearing - Roller	1
14	213052	Screw - Adjusting	1
15	110907	Ring - Retaining	1
16	84929	Nut - Bar Adjusting	1

Tools & Accessories

PART NUMBER	DESCRIPTION
95169	Kit - Spark Arrester
91485	Wrench - Socket
85687	Wrench - Screwdriver
88755	Scrench
93283	Case - Carrying, 12"
92976	Bar Guard, 12"
93090	Guide - Timing
68915A	Kit - Piston Tool
90256	Kit - Tune up
90607A	Guide - File
216063	Key - Socket - 5/32
216148	Key - Socket - 3/16

PART NUMBER	DESCRIPTION
216058	Key - Socket - 9/64
90958A	Kit - Tool Maintenance
93900	Kit - Pressure Test
90533	Tool - Pressure Test
501334	Tester - Ignition
68090	Lubri-Gun
85702	Lubricant - Custom, 6 oz. can
85703	Lubricant - Custom, 6 oz. cans, 1-6 pack
67537	Loctite
69794	Locquic
110083	R.T.V. Sealant