

MAC 2-10G

Serial Numbers Prefixed 2-

Figure and Item numbers are referenced to the Illustrated Parts List, P/N 65639 unless otherwise indicated on this parts list sheet. Numbers in black circles refer to notes at the bottom of the page. Numbers in parenthesis following the part number indicate a quantity change from the illustrated parts list.

FIG. & ITEM	PART NUMBER	NOMENCLATURE	FIG. & ITEM	PART NUMBER	NOMENCLATURE	FIG. & ITEM	PART NUMBER	NOMENCLATURE
1-1	Fig. reference		1-38	63073	Housing			
1-2	110403	Screw	1-39	103124	Screw			
1-3		① Screw	1-40	64856	Washer			
1-4	Fig. reference		1-41	55636	Washer			
1-5	102761	Screw	1-42	65726	Sleeve			
1-6	100352	Washer	1-43	Fig. reference				
1-7	61678	Plug	1-44	65604	Rod			
1-8	101326	Nut	1-45	65672	Gasket			
1-A	110448	Screw	1-46	65821	Insulator			
1-B	103174	Lockwasher	1-47	102290	Screw			
1-C	100003	Washer	1-48	63475	Lockplate			
1-D	64563	Bracket	1-49	55636	Washer			
1-E	102130	② Screw	1-50	110353	Screw			
1-F	100153	Washer	1-51	102289	Screw			
1-G	63484	Clamp	1-52	100352	Washer			
1-H	66341	Frame & Grip	1-53	63070	Brace			
1-J	62271	Plug	1-54	Fig. reference				
1-9		Screw	1-55	65674	Gasket			
1-10		③ Lockwasher	1-	63396	④ Insulator			
1-11		Washer	1-56	65905	Spark Arr.			
1-12		Frame	1-57	101284	Screw	2-12	62371	Retainer
1-13	103746	Nut	1-58	110264	Washer	2-13	63985	Shield
1-14	Fig. reference		1-59	62380	Cover	2-14	63986	Washer
1-15	103879	Key	1-60	62379B	Baffle	2-15	110470	Rivet
1-16	66032	Drum Assy	1-61	65805	Body	2-16	59952A	Rope
1-17	65748	Seal	1-62	110341	Screw	2-17	65526	Drum
1-18	102765	Screw	1-63	104534	Screw	2-18	36059	Spring
1-19	100003	Washer	1-64	104895	Screw	2-19	63987	Shield
1-20	Fig. reference		1-65	63748	Gasket	2-20	61635A	Bushing
1-21	106104	"O" Ring	1-66	65503	Shroud	2-21	65879	Housing
1-22	65866	Cover	1-67	62085A	Insulator			
1-23	65813	Nut	1-68	Fig. reference		3-1	66648	⑤ Tank
1-24	65458	Nameplate				3-	105788	Rivet
1-25	65815	Screen	2-1	65471	Clutch Assy	3-2	64872	Grip
1-26	61721D	Cap Assy	2-2	63999	Spring	3-3	105673	Pin
1-27	64762	Cover	2-3	64583	Retainer	3-4	66194	Button
1-28	63040	Spring	2-4	62198B	Shoe	3-5	64871	Button & Rod
1-29	62316	Guide	2-5	65475	Rotor	3-6	61696	Seal
1-30	63041	Valve	2-6	65472	Rivet	3-7	110378	Pin
1-31	65671	Gasket	2-7	62328	Spring	3-8	65734	Spring
1-32	110334	Screw	2-8	64857	Pawl	3-9	65864	Trigger
1-33	63656	Cover	2-9	65473	Washer	3-10	103672	Screw
1-34	62102	Gasket	2-	65880	Starter Assy	3-11	62973A	Wire
1-35	64848	Hose	2-10	62191A	Insert	3-12	62451	Contact
1-36	63932	Filter	2-11	62190A	Handle	3-13	62950A	Base
1-37	62978	Screw						

Changes in Figure 1.

2-12 62371 Retainer
 2-13 63985 Shield
 2-14 63986 Washer
 2-15 110470 Rivet
 2-16 59952A Rope
 2-17 65526 Drum
 2-18 36059 Spring
 2-19 63987 Shield
 2-20 61635A Bushing
 2-21 65879 Housing

3-1 66648 ⑤ Tank
 3- 105788 Rivet
 3-2 64872 Grip
 3-3 105673 Pin
 3-4 66194 Button
 3-5 64871 Button & Rod
 3-6 61696 Seal
 3-7 110378 Pin
 3-8 65734 Spring
 3-9 65864 Trigger
 3-10 103672 Screw
 3-11 62973A Wire
 3-12 62451 Contact
 3-13 62950A Base

Continued

NOTES

- ① Screw replaced by frame mounting Screw, P/N 110448, Item A, illustrated in changes to Figure 1 on this page.
- ② See changes to Figure 1 on this page.
 A Screw - Skt hd 10-24 x 3-1/4
 B Lockwasher - #10
 C Washer - #10
 D Bracket - Frame
 E Screw - Hex hd 1/4-20 x 1-1/2
 F Washer - 1/4
 G Clamp - Frame

- H Frame and Grip Assy
 J Plug - Frame
- ③ Screw, Washers and Frame replaced by parts listed in Note 2.
- ④ Fuel tank insulator shown in Figure 3, Item 15.
- ⑤ Fuel tank assembly includes two Rivets, P/N 105788, in bottom of tank. Items 2 to 15 inclusive, are not included in this tank assembly.

FIG. & ITEM	PART NUMBER	NOMENCLATURE	FIG. & ITEM	PART NUMBER	NOMENCLATURE	FIG. & ITEM	PART NUMBER	NOMENCLATURE
3-14	62951	Button	5-5	101174	Washer			
3-15		⑥ Insulator	5-6	101191	Nut			
3-16	65816	Rod	5-7		⑦ Spike			
4-	66503	Carburetor	5-8	60972	Nut			
4-1	110397	Screw	5-9	63997A	Plate			
4-2	65597	Plate	5-10	36644A	⑧ Sprocket			
4-3	65598	Diaphragm	5-11	63808	Key			
4-4	55690B	Seal	5-12	64754	Spacer			
4-5	65868	Valve Set	5-13	110406	Screw			
4-6	66153	Seat	5-	65882	Pump Assy			
4-7	61151	Ball	5-14	105559	Plug			
4-8	63041 (1)	Valve	5-15	110392	Pin			
4-9	104814	Screw	5-16	63428	Plunger			
4-10	62290A	Plate	5-17	65881	Body			
4-11	65677	Retainer	5-18	62909	Valve			
4-12	65617	Plug	5-19	63692	Spring			
4-13	105617	"O" Ring	5-20	63474	Gasket			
4-14	101289	Ring	5-21	102765	Screw			
4-15	65859	Spring	5-22	100003	Washer			
4-16	66552	Plunger	5-	66208	Trans. Assy			
4-17	66551	"O" Ring	5-23	104360	"O" Ring			
4-18	104728	Screw	5-24	110055	Screw			
4-19	110337	Pin	5-25	63491	Filler			
4-20	62310	Lever	5-26	110417	Screw			
4-21	62923A	Spring	5-27	63416	Plate			
4-22	63038	Valve	5-28	102067	Nut			
4-23	65445	Needle	5-29	110387	Washer			
4-24	104001	"O" Ring	5-30	63824A	Nut			
4-25	110483	Screw	5-31	102144	Screw			
4-26	104814	Screw	5-32	101174	Washer			
4-27	65430	Lever	5-33	110405	Screw			
4-28	65431	Needle	5-34	64779	Cover			
4-29	62975	Swivel	5-35	101775	Plug			
4-30	65428	Shaft	5-36	63477	Seal			
4-31	66504	Body	5-37	63433	Gasket			
4-32	65432	Orifice	5-38	63478	Seal			
4-33	63813	Orifice	5-39	110348	Bearing			
4-34	59796	"O" Ring	5-40	64775	Gear			
4-35	65724	Stud	5-41	110452	"O" Ring			
4-36	62368	Bushing	5-42		⑨ Bearing			
4-37	62435	Seal	5-43	66616	⑩ Gear Assy			
5-1	103729	Nut	5-44	64770	Gearcase			
5-2	100006	Washer	5-45	101770	Pin			
5-3	63417	Plate	5-46	64584	Bolt			
5-	63994	Spike Kit	5-47	64935	Plate			
5-4	110245	Screw	5-48		Bar			
			5-49		Chain			
			6-1	101391	Nut			

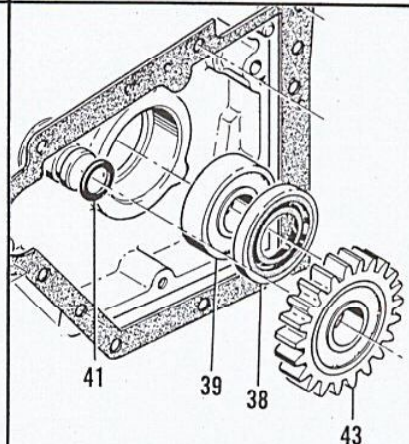

Changes to Figure 5.

6-2	61737A	Flywheel
6-3	103879	Key
6-4	101965	Screw
6-5	100003	Washer
6-6	51253	Retainer
6-7	62741	Lamination
6-8	62819	Wire
6-9	62818A	Wire
6-10	62927A	Coil
6-11	62929A	Wire
6-12	62932	Connector
6-13	62926	Boot
6-14	63097	Spark Plug
6-15	110349	Screw
6-16	62362	Cover
6-17	100298	Nut
6-18	62365	Spacer
6-19	110346	Screw
6-20	100934	Screw
6-21	105976	Washer
6-22	105249	Screw
6-23	61650	Condenser
6-24	62363	Breaker
6-25	54184	Wiper
6-26	62361	Box
6-27	100414	Screw
6-28	100955	Nut
6-29	62261A	⑪ Housing
6-30	62262	Cap

Continued

NOTES

- ⑥ Insulator listed as Item 1-K on this parts list sheet.
- ⑦ Spike not available. Order Spike Kit, P/N 63994.
- ⑧ 7 tooth, 1/2-inch pitch. Order Sprocket, P/N 52069A, for use with .404-inch pitch chain.
- ⑨ Bearing not available. Order Idler Gear Assy, P/N 66616.
- ⑩ Gear assembly includes bearing. See changes to Figure 5 on this page.
- ⑪ Pump housing only. Not furnished as a complete pump assembly.

FIG. & ITEM	PART NUMBER	NOMENCLATURE	FIG. & ITEM	PART NUMBER	NOMENCLATURE	FIG. & ITEM	PART NUMBER	NOMENCLATURE
6-31	62266	Plunger	6-50	100010	Cotter			
6-32	101056	"O" Ring	6-51	61649	Pin			
6-33	66687	Spring	6-52	62824	Piston Assy			
6-34	62230	Gasket	6-53	62814	Ring Set			
6-35	62909	Valve	6-54	103512	Bearing	1	66285	Manual
6-36	110407	Screw	6-55	65401	Conn Rod	2	51445A	Wrench
6-37	63974	Cover	6-56	61627A	Screw	3	62825	Piston Assy
6-38	63442	Gasket	6-57	63225	Needle Set	4	62813	Ring Set
6-39	57129A	Cap	6-58	65746	Oil Seal	5	103512	Bearing
6-40	101148	"O" Ring	6-59	63464	Ring	6	62826	Piston Assy
6-41	62123B	Hose	6-60	63429B	Bearing	7	62812	Ring Set
6-42	51506	Screen	6-61	66030	Insert Assy	8	103512	Bearing
6-43	65385	Crankcase	6-62	65747	Oil Seal	9		12 Frame
6-44	62105	Screw	6-63	63699	Ring	10	65325	Screen
6-45	62842	Washer	6-64	104357	Bearing	11	63432	Spark Plug
6-46	110404	Screw	6-65	63401A	Crankshaft	12	65778	Spark Plug
6-47	110288	Screw	6-66	105221	Screw	13	62142A	Lock
6-48	63607	Screw	6-67	101191	Nut	14	63357	Probe
6-49	63606	Washer	6-68	65363	Guard	15	65712	13 Timing Guide

ACCESSORY ITEMS

NOTES

12 Wrap-around frame is standard equipment. See changes to Figure 1 on page 1 of this sheet.

13 Timing Guide added to Accessory list.



McCULLOCH CORPORATION
6101 WEST CENTURY BLVD., LOS ANGELES, CALIFORNIA 90045

McCULLOCH OF CANADA, LTD.
77 BELFIELD ROAD, REXDALE, ONTARIO, CANADA

McCULLOCH INTERNATIONAL, INC.
ARKSTRAAT 5, MECHELEN, BELGIUM
G. P. O. BOX 879, HONG KONG, B. C. C.

McCULLOCH OF AUSTRALIA PTY., LTD.
P. O. BOX 165, SOUTH GRANVILLE, N. S. W., AUSTRALIA

McCULLOCH INTERNATIONAL (U.S.), INC.
P. O. BOX 45466 LOS ANGELES, CALIFORNIA, U. S. A.

66709