

CHAIN IDENTIFICATION

GENERAL PURPOSE

General purpose C3F Chain cuts smoothly in all types of wood from soft to very hard or frozen. Bores and blind-cuts in both soft and hard woods. Specially recommended for saws with 20 inch or smaller attachments for cutting small or medium size timber.

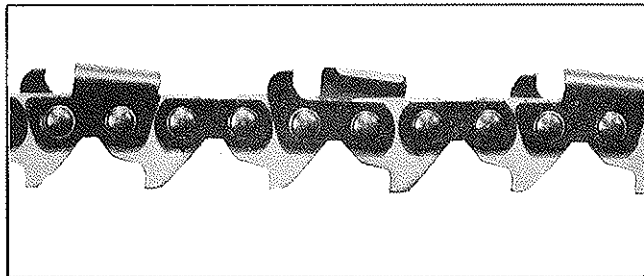

C3F CHAIN 260 SERIES FOR HM-90 SERIES CUTTER BARS

BAR SIZE	CHAIN LENGTH UNCOUPLED	NUMBER OF DRIVE LINKS	PART NUMBER
12"	38.75"	48	470577
16"	44.8"	56	470055
20"	51.2"	64	470056
24"	57.6"	72	470057
28"	67.2"	84	470058
32"	80.0"	100	470059

AVAILABLE IN 260 SERIES ONLY

C3FH CHAIN 260 SERIES FOR HM-90 SERIES CUTTER BARS

BAR SIZE	CHAIN LENGTH UNCOUPLED	NUMBER OF DRIVE LINKS	PART NUMBER
12"	38.75"	48	470578
16"	44.8"	56	470281
20"	51.2"	64	470075
24"	57.6"	72	470076
28"	67.2"	84	470077
32"	80.0"	100	470078

HARD WOOD

Use C3FH Chain where ruggedness and speed is desired on 24 inch or longer attachments when cutting hard or mixed woods. Same basic design as C3F, but has heavier cutters and side links for added strength.

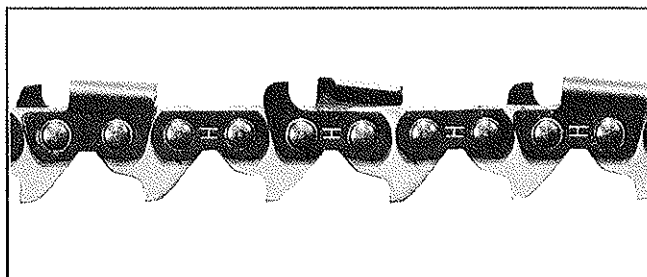

C3FH CHAIN 261 SERIES FOR JB-90 SERIES CUTTER BARS

20"	57.6"	72	470283
26"	70.4"	88	470284
32"	83.6"	105	470285
40"	93.6"	117	470286
50"	115.2"	144	470287

C3GH CHAIN 260 SERIES FOR HM-90 SERIES CUTTER BARS

BAR SIZE	CHAIN LENGTH UNCOUPLED	NUMBER OF DRIVE LINKS	PART NUMBER
12"	38.75"	48	470580
16"	44.8"	56	470084
20"	51.2"	64	470085
24"	57.6"	72	470086
28"	67.2"	84	470087
32"	80.0"	100	470088

SOFT WOOD

For exceptionally fast cutting of soft or medium wood with 24 inch or longer attachments, we recommend the C3GH. Blind-cuts and bores well in this type of wood with the extra clearance necessary in long cutting attachments.

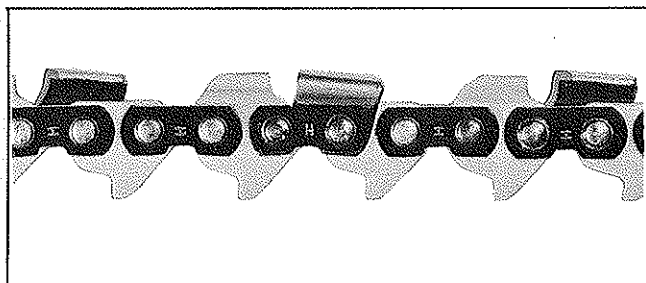

C3GH CHAIN 261 SERIES FOR JB-90 SERIES CUTTER BARS

20"	57.6"	72	470095
26"	70.4"	88	470096
32"	83.6"	105	470097
40"	93.6"	117	470098
50"	115.2"	144	470282

CHAIN DETAILS

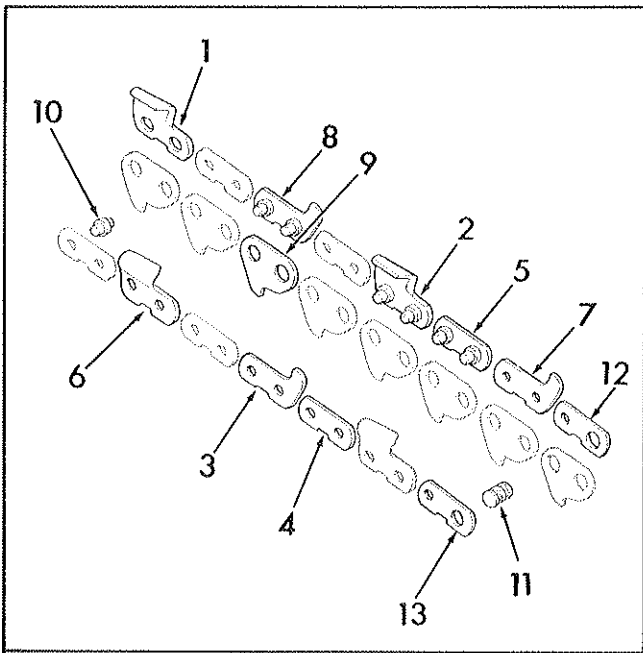

TYPE C3F AND C3FH



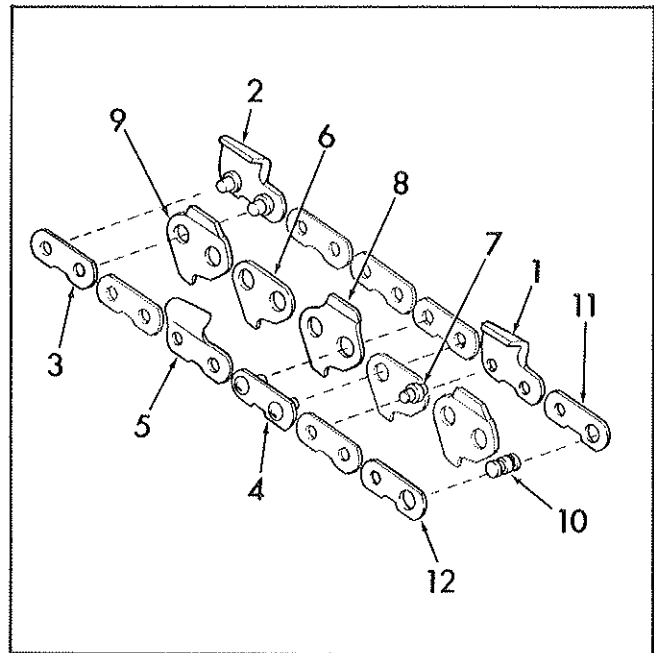











REF. NO.	PART DESCRIPTION
1	Right Cutter
2	Right Cutter With Two Rivets, Pre-Set
3	Side Link With Jointer, LH
4	Side Link
5	Side Link With Two Rivets, Pre-Set
6	Left Cutter
7	Side Link With Jointer, RH
8	Side Link With Jointer, Two Rivets, Pre-Set, RH
9	Center Link
10	Rivet
11	Master Rivet
12	RH Master Link
13	LH Master Link



TYPE C3GH

REF. NO.	PART DESCRIPTION
1	Right Cutter
2	Right Cutter With Two Rivets, Pre-Set
3	Side Link
4	Side Link With Two Rivets, Pre-Set
5	Left Cutter
6	Center Link
7	Rivet
8	Center Link With Jointer, RH
9	Center Link With Jointer, LH
10	Master Rivet
11	RH Master Link
12	LH Master Link

CHAIN REPAIR PARTS

	TYPE	C3F	C3FH	C3G	C3GH	C3FH	C3GH
	SERIES	260	260	260	260	261	261
	PITCH	.400	.400	.400	.400	.400	.400
	GAUGE	.060	.060	.060	.060	.060	.060
	RIVET	**425345	**425345	**425345	**425345	**425345	**425345
	RIGHT CUTTER	425250	425294	425250	425294	425294	425294
	RIGHT CUTTER WITH 2 RIVETS, PRE-SET	*470295	*470304	*470295	*470304	*470304	*470304
	LEFT CUTTER	*425251	*425296	*425251	*425296	*425296	*425296
	CENTER LINK	*425248	*425248	*425248	*425248	*425248	*425248
	CENTER LINK WITH JOINT, RH			*425347	*425347		*425347
	CENTER LINK WITH JOINT, LH			*425348	*425348		*425348
	SIDE LINK	*425246	*425286	*425246	*425286	*425286	*425286
	SIDE LINK WITH 2 RIVETS, PRE-SET	*470294	*470303	*470294	*470303	*470303	*470303
	SIDE LINK WITH JOINT, RH	425921	425283			425283	
	SIDE LINK WITH JOINTER, 2 RIVETS, PRE-SET, RH	*470296	*470297			*470297	
	SIDE LINK WITH JOINT, LH	*425284	*425285			*425285	
	MASTER RIVET					425925	425925
	RH MASTER LINK					425923	425923
	LH MASTER LINK					425924	425924
	REPAIR PARTS KIT	470054	470298	470300	470301	470298	470301

*One each supplied in Repair Parts Kit.
 **Four rivets supplied in Repair Parts Kit.

REEL CHAIN

TYPE	C3F	C3FH	C3GH
50 FOOT REEL	*470367	*470369	*470374
100 FOOT REEL	**470368	**470370	**470375
JOINING KITS (With 50' reel)	1-470376	1-470371	1-470371
(With 100' reel)	2-470376	2-470371	2-470371

CONTENTS OF JOINING KITS (supplied with reels)

KIT PART NO.	QTY.	CONTAINS	
		PART NO.	DESCRIPTION
470371	12	470303	Side Link with 2 Rivets Pre-set
	12	425286	Side Link
470376	12	470249	Side Link with 2 Rivets Pre-set
	12	425246	Side Link

*Includes 12 Repair Parts Kits.
 **Includes 24 Repair Parts Kits.

CUTTER BARS

TYPE HM-90 SERIES

For Models HA, HB, HC, HM, RA and 400 and 600 Series.

TYPE JB-90 SERIES

For Models JA, JB and JC

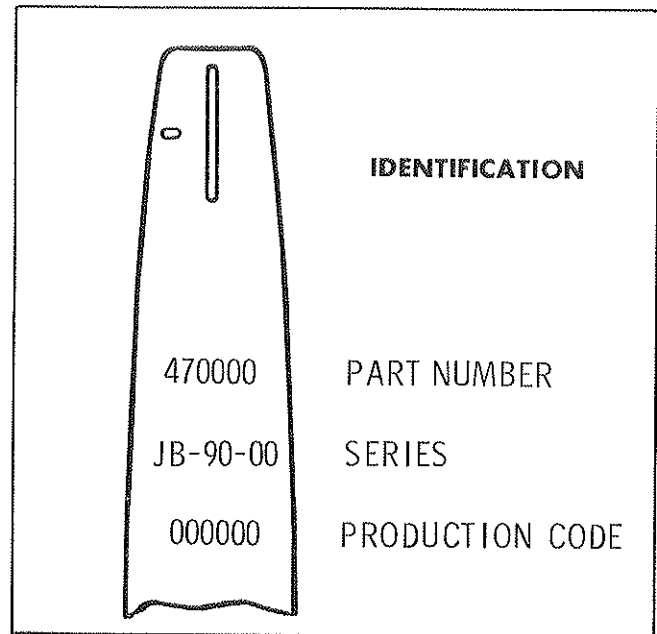
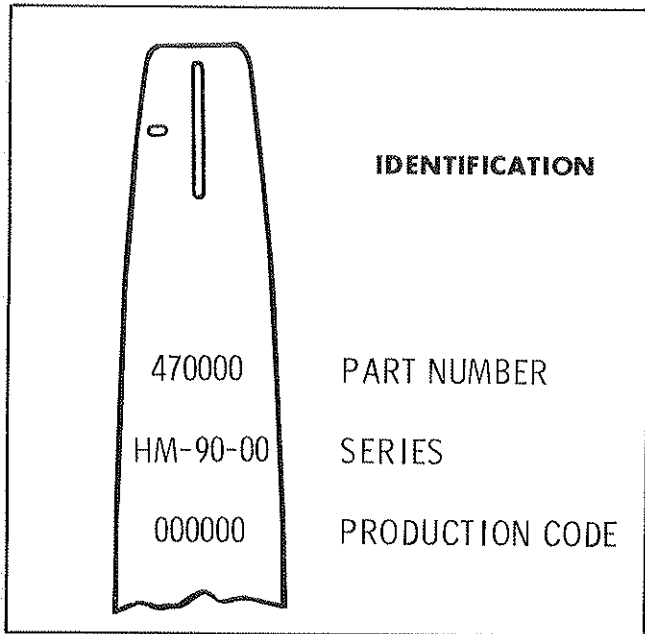

ACTUAL CUTTING LENGTHS OF HM SERIES AND JB SERIES CUTTER BARS

PART NUMBER	SERIES AND NOMINAL LENGTH	TOTAL LENGTH	ACTUAL CUTTING LENGTH		POSSIBLE ADJUSTMENT IN SLOT	CUTTING LENGTH WITH HELPER'S HANDLE
			WITHOUT PIVOT GRIP (A)	WITH PIVOT GRIP (B)		
470582	HM-90-12"	15.947"	13.45"	11.88"	.875"	----
470060	HM-90-16"	19.032"	16.53"	14.97"	.875"	----
470061	HM-90-20"	22.200"	19.70"	18.14"	.875"	----
470062	HM-90-24"	25.447"	22.95"	21.38"	.875"	----
470063	HM-90-28"	30.262"	27.76"	26.20"	.875"	----
470064	HM-90-32"	36.641"	34.14"	32.58"	.875"	----
470461	JB-90-20"	25.555"	20.18"	18.63"	1.250"	----
470462	JB-90-26"	32.000"	26.62"	25.07"	1.250"	----
470463	JB-90-32"	38.562"	33.19"	31.64"	1.250"	30.25"
470464	JB-90-40"	43.427"	38.05"	36.50"	1.250"	35.11"
470465	JB-90-50"	54.432"	49.06"	47.51"	1.250"	46.12"

BOW RAIL

PART NUMBER	NOMINAL LENGTH	ACTUAL CUTTING CAPACITY
426112	14"	13.5"
426733	18"	17.0"

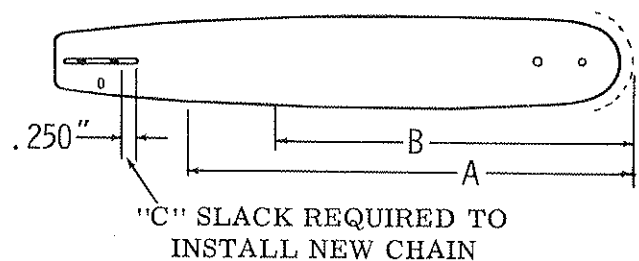

OPTIONAL EQUIPMENT

400 SERIES WRAP AROUND HANDLEBAR

PART NO. 470671

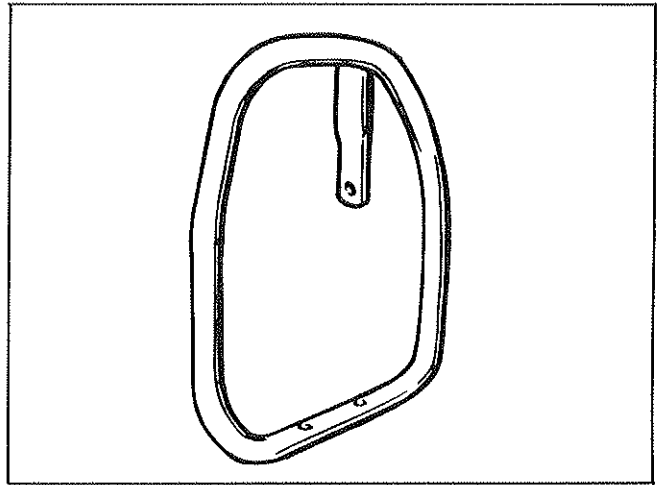

MODEL RA SNOW GUARD

PART NO. 426068 FOR MOTOR
SERIAL NOS. TO 23,000

PART NO. 426069 FOR MOTOR
SERIAL NOS. 23,000 AND UP

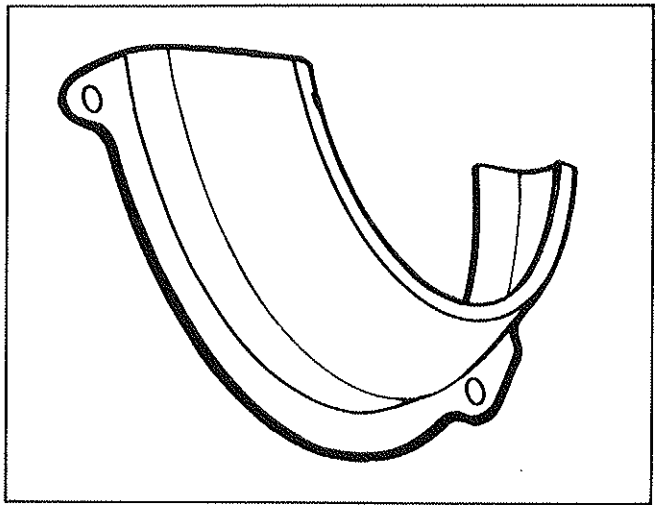

HELPER HANDLE

USE ONLY WITH
CUTTER BARS

JB-90-32"
JB-90-40"
JB-90-50"

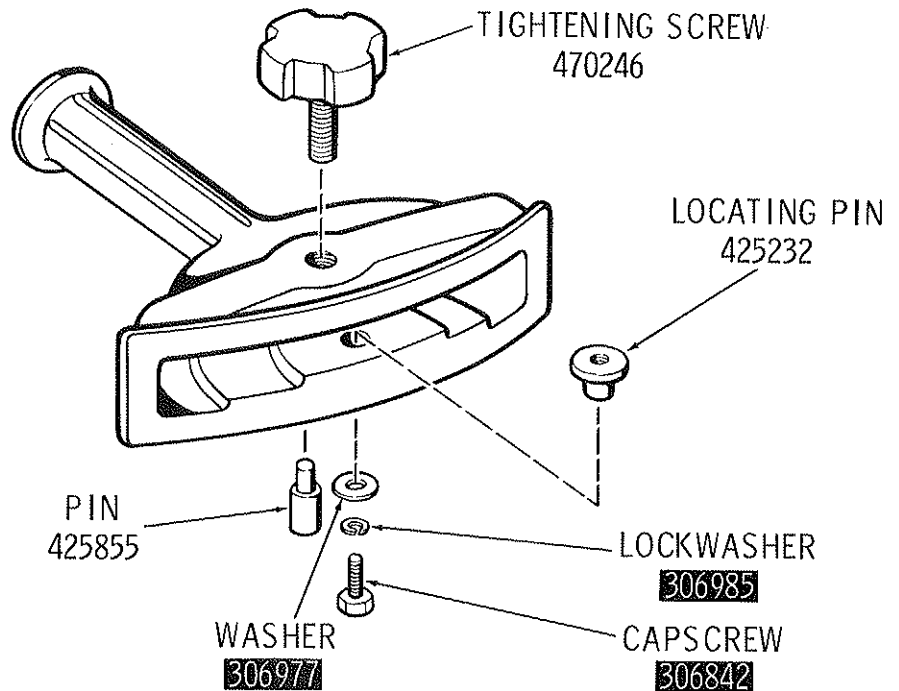

OPTIONAL EQUIPMENT

MODEL RA AIR CLEANER CONVERSION

PART NO. 470423

1. 426167 FILTER COVER
2. 470407 PACKAGED AIR CLEANER ELEMENT
3. 470422 SUPPORT PLATE AND GASKET ASSEMBLY
4. 425669 GASKET - FILTER BASE

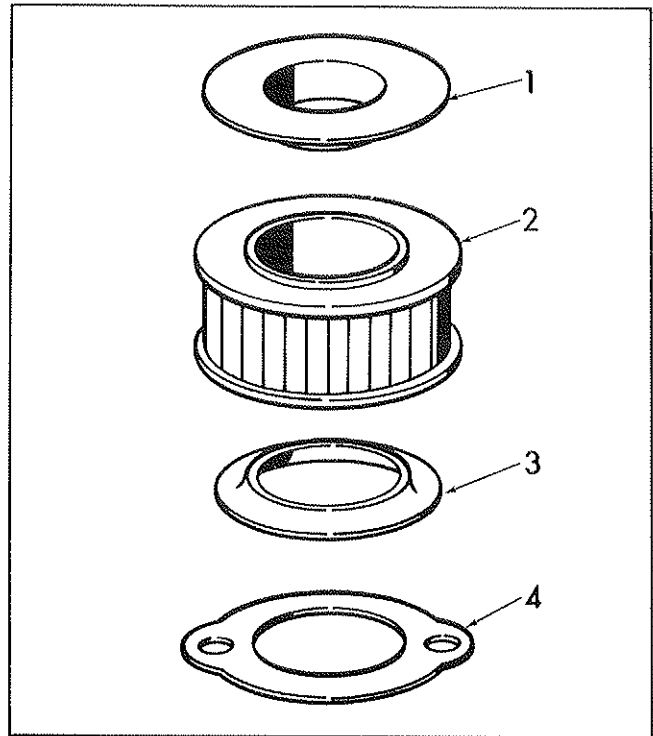

MODEL RA AIR FILTER BODY ASSEMBLY PARTS

PART NO. 470179

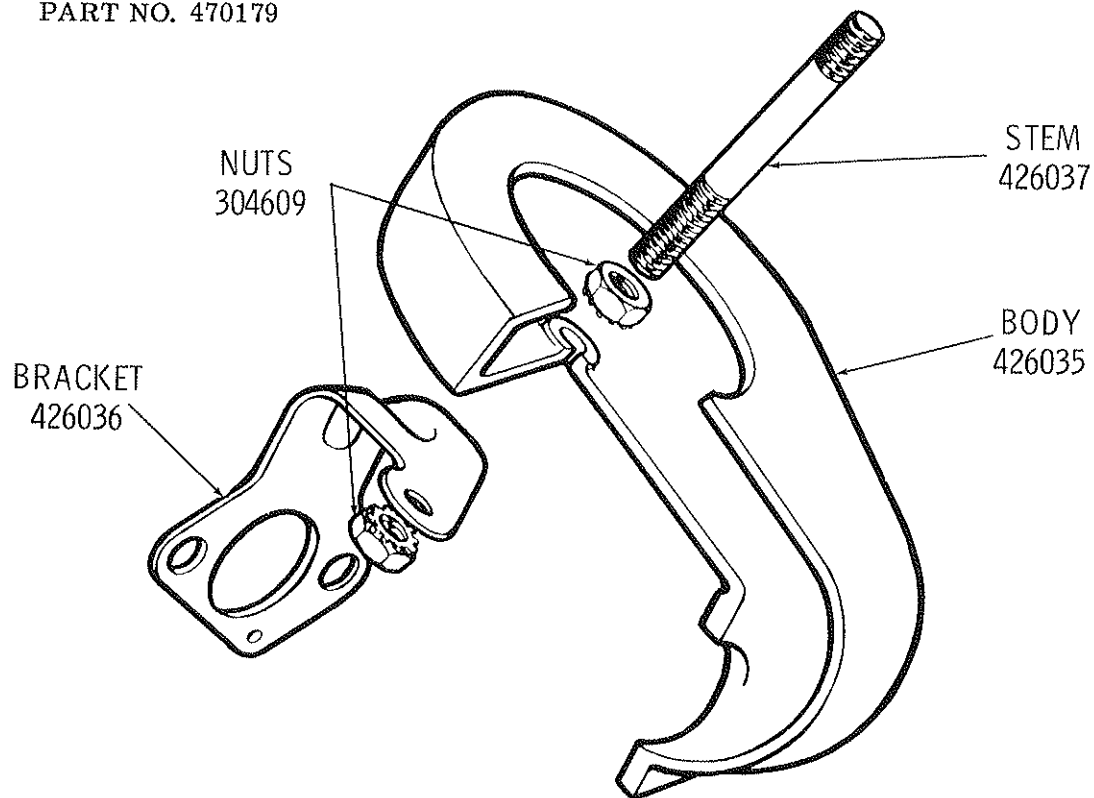

600 SERIES OPTIONAL EQUIPMENT

PIVOT GRIP

PIVOT GRIP PARTS LIST

Ref. No.	Part No.	Description	Qty. Req'd.
1	426203	Pivot Grip, Eastern	1
2	130491	Screw	2
3	425713	Nut	2
4	303248	Bolt	1
5	426202	Pivot Grip, Western	1
6	130491	Screw	2
7	425713	Nut	2
8	303348	Bolt	1

HALF HANDLE

HALF HANDLE PARTS LIST

Ref. No.	Part No.	Description	Qty. Req'd.
1	470601	Half Handle	1
2	130491	Screw	1
3	425713	Nut	1

BOW ATTACHMENT

BOW ATTACHMENT PARTS LIST

Ref. No.	Part No.	Description	Qty. Req'd.
*	470601	Bow Attachment, Complete - 14 Inch	1
†	470687	Bow Attachment Complete - 18 Inch	1
1	426142	Bow Rail - 14 Inch	1
1	426733	Bow Rail - 18 Inch	1
2	426110	Guard	1
3	306435	Capscrew	2
4	306325	Lockwasher	2
5	302103	Hex Nut	2
**	470703	Bow Spike Assembly	1
6	426881	Spike	2
7	600014	Capscrew	2
8	306375	Hex Nut	2
9	426691	Spacer	2
10	308163	Flat Head Screw	1
**	470102	Strut Assy. Modified For Bow Attachment, Model RA	1
**	470719	Strut Assy. Modified For Bow Attachment, 60D Series	1

*Includes 14 in. Bow Rail and Items 2 thru 9.
 †Includes 18 in. Bow Rail and Items 2 thru 9.
 **Not Shown

NOTE

The 14" Bow Attachment Part No. ~~470601~~ requires a C3 -- 260 - 24" .4 pitch chain.
(TYPE)

The 18" Bow Attachment Part No. ~~470687~~ requires a C3 -- 260 - 28" .4 pitch chain.
(TYPE)

WHEN ORDERING SPECIFY CHAIN TYPE

SPECIAL SERVICE TOOL KIT PART NO. 470736
(COMPOSED OF THE FOLLOWING ITEMS)

**CONNECTING ROD CAP
INSTALLING TOOL**

PART NO. 426014

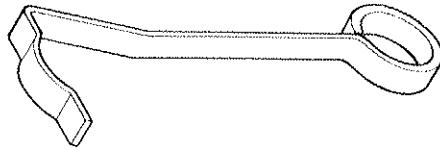

**CRANKSHAFT DRIVER NUT - LH
THREAD**

PART NO. 426015

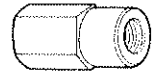

**CRANKSHAFT DRIVER NUT -
RH THREAD**

PART NO. 426016



SEAL STARTER-CLUTCH END
PART NO. 426017



CLUTCH END SEAL DRIVER

PART NO. 426018



CRANKSHAFT WEB SCREW JACK

PART NO. 426019

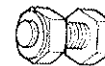

RING COMPRESSOR

PART NO. 426020

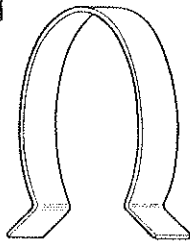

**CRANKSHAFT LOCKING TOOL -
MODEL RA AND 400 AND
600 SERIES**

PART NO. 426021

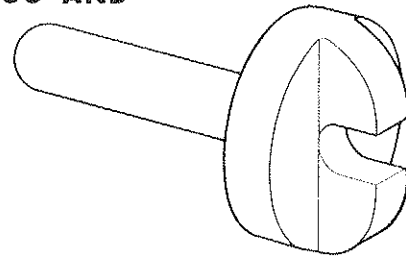

**CRANKSHAFT LOCKING TOOL -
H AND J SERIES**

PART NO. 426022

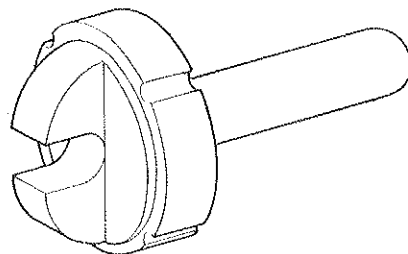

SPROCKET BEARING DRIVER

PART NO. 426023

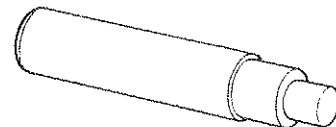

**CONNECTING ROD CAP SCREW
ALLEN WRENCH - 3/8" DRIVE**

PART NO. 426024



TIMING ARM - 400 SERIES

PART NO. 426847

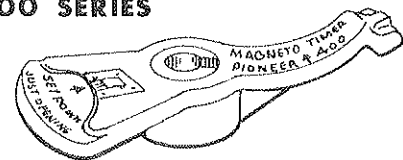

**WRIST PIN DRIVER AND
CONNECTING ROD,
PISTON LOCATING PIN**

PART NO. 470333

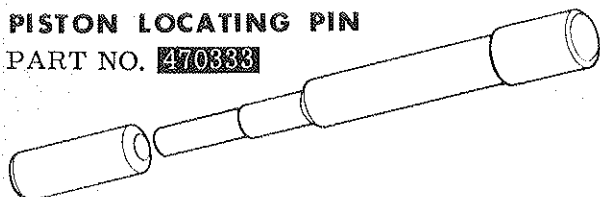

**SEAL DRIVER - WITH EXTRA BASE
PLATE FOR GARLOCK SEAL**

PART NO. 470334

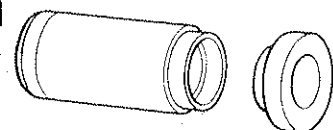

SPECIAL SERVICE TOOL KIT PART NO. 470736
(CONTINUED)

MAIN BEARING DRIVER

PART NO. 470885

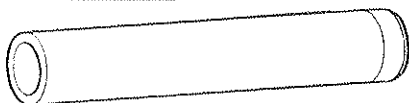

CONNECTING ROD BEARING DRIVER

PART NO. 470886

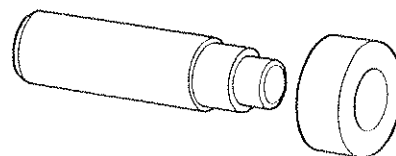

COMBINATION CLUTCH, FAN HOUSING AND FLY WHEEL PULLER
PART NO. 470882

1	426053	Puller Plate	1
2	426143	No. 12-24 x 3-1/2 Rd. Hd. Machine Screw	2
3	426052	Puller Screw	1
4	306000	5/16 Allen Key	1
5	306519	No. 10-24 x 1-1/2 Rd. Hd. Machine Screw	3
6	306001	1/4 x 20 x 1-1/2 Rd. Hd. Machine Screw	3
7	306890	1/4 x 20 x 2-1/2 Rd. Hd. Machine Screw	3
8	306375	1/4 x 20 Hex Nuts	3
9	306531	No. 10-24 Hex Nuts	3

FAN HOUSING SEAL DRIVER

PART NO. 470694



MAIN BEARING PULLER

PART NO. 470706

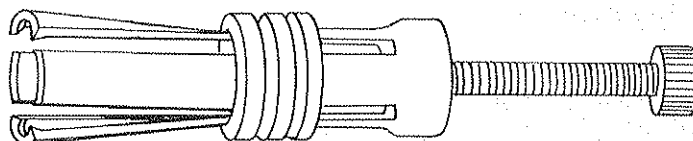

SPECIAL TOOLS

SPARK PLUG WRENCH

PART NO. 425733

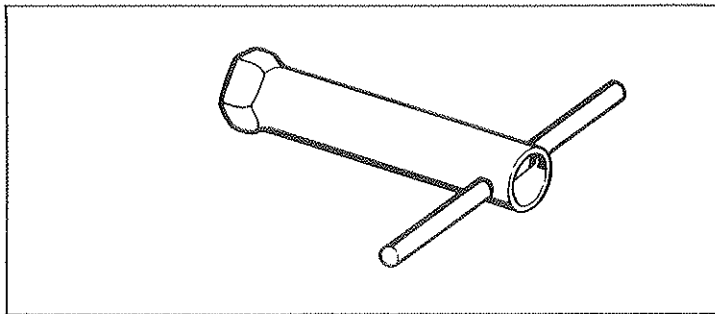

COMBINATION WRENCH

PART NO. 425580

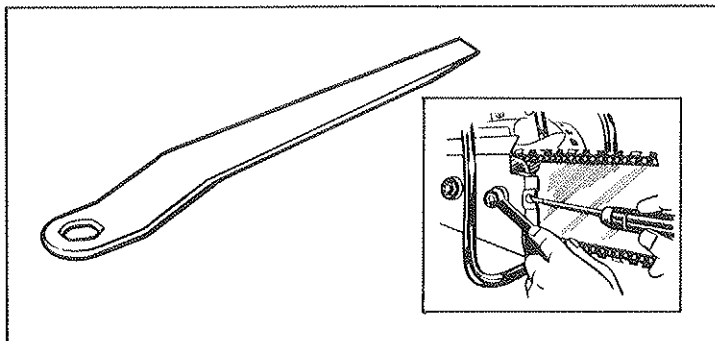

TIMING LIGHT

PART NO. 470433

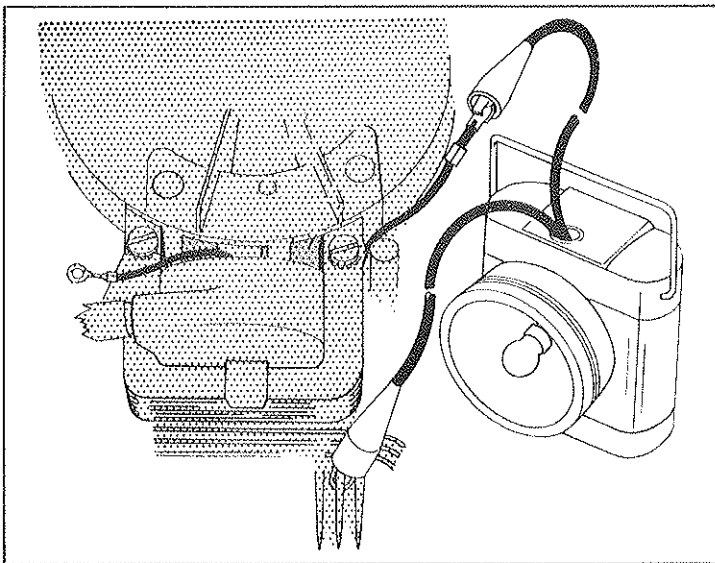

AIR LEAK TESTER

PART NO. 470757

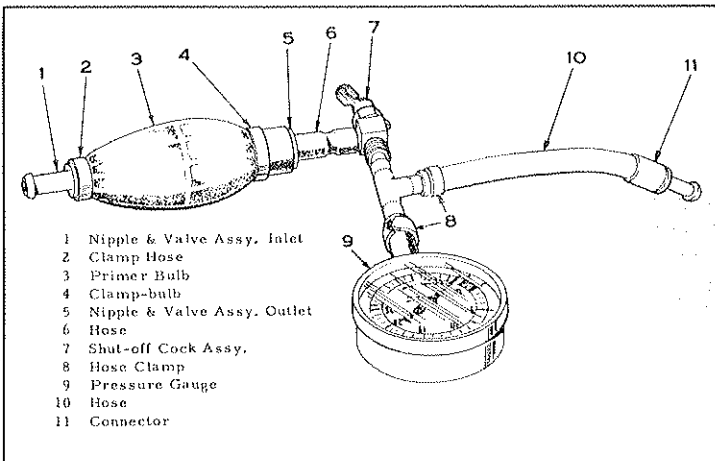

SPECIAL TOOLS

JOINTING GAUGE
PART NO. 470163

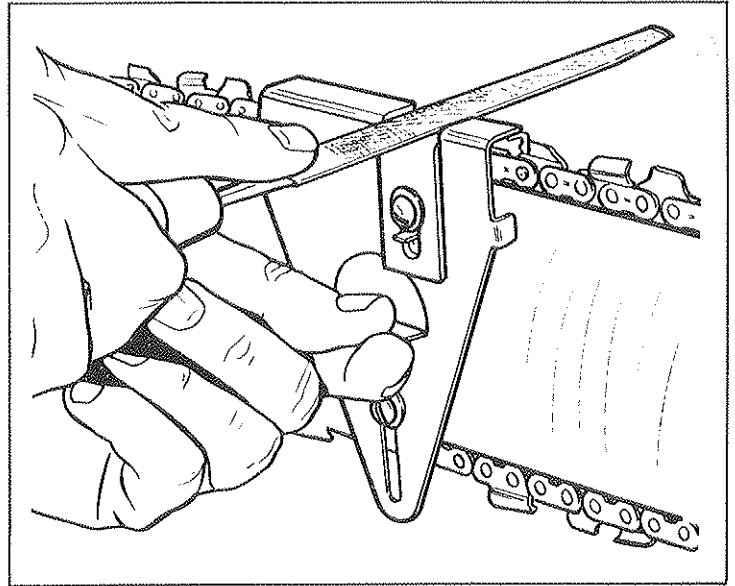

FULL ROUND FILE

1/4 x 8 inch
PART NO. 425592

7/32 x 8 inch
PART NO. 425598

5/16 x 8 inch
PART NO. 425901

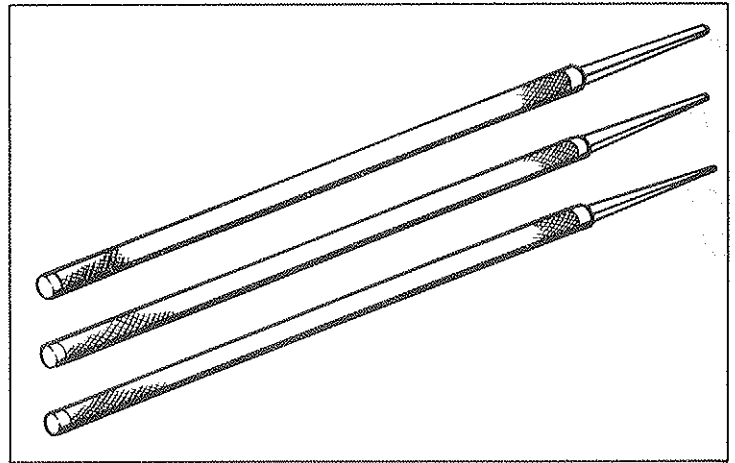

TORQUE WRENCH
PART NO. ~~426028~~

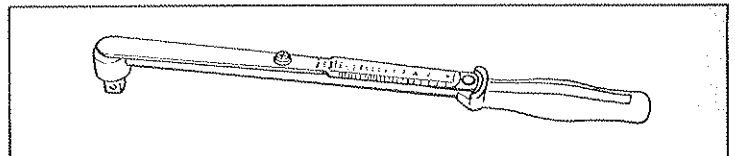

BAR GROOVE GAUGE
PART NO. 426235

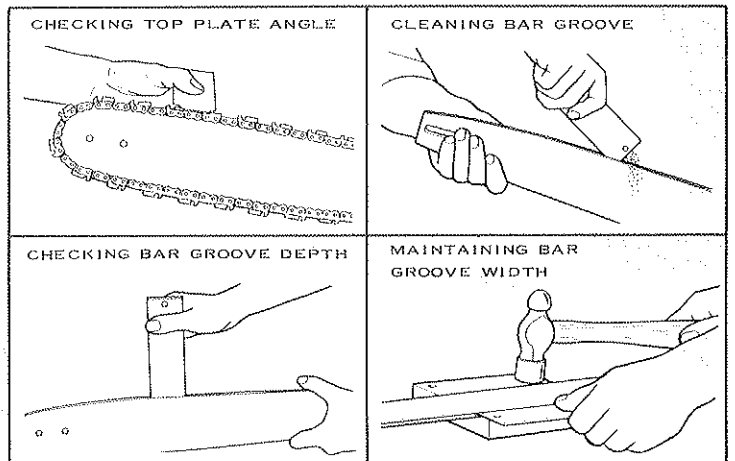

QUICK REFERENCE CHART OF ACTIVE SERVICE PARTS

MODELS ENGINE	HA	HB	HC	HM	JA	JB	JC	RA	400 SERIES	600	600A 610
CRANKSHAFT	425009	425009	425009	425009	425311	425311	425311	425311	426402	426209	426209
CONNECTING ROD	*470168	*470168	*470168	*470168	*470168	*470168	470168	470168	470168	470168	470168
BEARING CAGE (MATCHED SET)	*470731	*470731	*470731	*470731	*470731	*470731	470731	470731	470731	470731	470731
NEEDLE ROLLERS	*425089	*425089	*425089	*425089	425089	425089	425089	425089	425089	425089	425089
MAIN BEARINGS (BALL)	425066	425066	425066	425066	425066	425066	425066	425066	425066	425066	425066
MAGNETO SEAL	425076	425076	425076	425076	425076	425076	425076	425076	425076	425076	425076
DRIVE END SEAL	425077	425077	425077	425077	425077	425077	425077	425077	425077	425077	425077
CYLINDER ASSY.	470000	470000	470000	470000	470357	470357	470357	470190	470592	470468	470468
STD. PISTON	425032	425032	425032	425032	425306	425306	425306	425640	425640	425640	425640
.020 OVERSIZE PISTON	425568	425568	425568	425568	426138	426138	426138	426137	426137	426137	426137
WRIST PIN	425058	425058	425058	425058	425308	425308	425308	425641	425641	425641	425641
STD. PISTON RING SET	470778	470778	470778	470778				470777	470777	470777	470777
STD. PISTON RINGS					425307	425307	425307				
.020 OVERSIZE PISTON RINGS	425567	425567	425567	425567	426141	426141	426141	426140	426140	426140	426140
STARTER ASSEMBLY											
ROPE	*425596	425271	425271	425271	425846	425846	425846	425271	426752	425596	425271
HANDLE	*602773	*602773	*602773	*602773	*602773	*602773	*602773	*602773	602773	602773	602773
HANDLE ANCHOR	*304323	*304323	*304323	*304323	*304323	*304323	*304323	*304323	304323	304323	304323
PAWL ASSY.	470234	470233	470233	470233	470233	470233	470233	470233	470233	470233	470233
PULLEY (ROTOR)	470166	425270	425270	425270	425849	425849	425849	425270	470588	470426	425270
REWIND SPRING	425540	425276	425276	425276	425848	425848	425848	425276	426458	426217	425276
CUP		*426784	*426784	*426784	*426784	*426784	*426784	*426784			426784
FRICITION YOKE									426457	426212	
FRICITION WASHER									426927	426213	
PAWL OPERATING SPRING										303316	
STARTER PAWL	425546									426211	
PAWL OPERATING LINK										426214	
CARBURETOR	SEE PAGE II-13										

MAGNETO												
COIL	425371	425371	425371	425371	425371	425371	425371	425371	425371	425371	425371	425371
CONDENSER	425373	425373	425373	425373	425373	425373	425373	425373	425373	425373	425373	425373
BREAKER POINTS	425372	425372	425372	425372	425372	425372	425372	425372	425372	425372	425372	425372
CAM	425826	425826	425826	425826	425826	425826	425826	425826	425826	425826	425826	425826
CLUTCH												
SHOES	*470667	*470667	*470667	*470667	*470667	*470667	*470667	*470667	*470667	*470667	*470667	*470667
SPRINGS	425012	425012	425012	425012	425012	425012	425012	425012	425012	425012	425012	425012
DRIVER	425018	425018	425018	425018	425018	425018	425018	425018	425018	425018	425018	425018
DRIVER PIN	425019	425019	425019	425019	425019	425019	425019	425019	425019	425019	425019	425019
DRIVER CLIP	202139	202139	202139	202139	202139	202139	202139	202139	202139	202139	202139	202139
SPROCKETS												
.4 PITCH SPROCKET AND DRUM ASSY.	*470340	*470340	*470340	*470340	*470340	*470340	*470340	*470340	*470340	*470340	*470340	*470340

*Service Replacement - Not Original Equipment

GASKET CHART

	400 SERIES	500 SERIES	MODEL PA
ENGINE			
Cylinder Base	426453	426204	425644
Cylinder Head	426444	425553	425643
Exhaust	426144	426203	425325
Side, Nozzle	426140		
Air Box Front Section	426651		
OIL PUMP			
Gland Nut		425093	425093
Oil Body		426199	425671
Oil Filler Cap	426074	425074	425074
MAGNETO			
Breaker Box Cover		425690	425690
FUEL SYSTEM			
Filter Cap	426464		
Air Cleaner		425669	425669
Air Filter Base		425748	425748
Filter Bowl	425087	425067	425067
Fuel Cap	426620		
Primer Body			
CARBURETOR			
Adapter to Crankcase	425046	426120	425046
Diaphragm Cover	425586	426044	425044
Fuel Inlet Connection	426601	425495	425495
Fuel Pump Body	425586	425606	425606
Fuel Strainer		425493	425493
Inlet Seat	426505	425486	425486
Insulating Block to Crankcase	426105		

CARBURETOR SPECIFICATIONS

MODEL SAW	CARBURETOR PART NO.	MFG. PART NO.	INITIAL PRODUCTION YEAR	GASKET PACKING KIT	REPAIR PARTS KIT	CARBURETOR BODY	NORMAL SETTING HI SPEED	NORMAL SETTING LOW SPEED	INLET NEEDLE & SEAT	MAIN DIAPHRAGM	PUMP DIAPHRAGM
HA	470252	MD-55B	1953	GS-117	470326	425474	1 Turn Open	1/2 Turn Open	470115	-	-
HB	470252	MD-55B	1953	GS-117	470326	425474	1 Turn Open	1/2 Turn Open	470115	-	-
HM	470049	HP-13A HP-13B	1954	470321	470323	Not Available	1-1/4 Turn Open	1 Turn Open	470122	425465	425480
HC	470004	HL-8A	1956	470322	470324	470544	1-1/4 Turn Open	3/4-1 Turn Open	470734	470361	425495
JA	Use 470451	HL-8AX HL-16A	1956	470322	470324	470448	1-1/4 Turn Open	3/4 Turn Open	470734	470361	425495
JB	Use 470451	HL-16A	1956	470322	470324	470448	1-1/4 Turn Open	3/4 Turn Open	470734	470361	425495
RA	470171	HL-22A	1957	470322	470325	470350	1-1/4 Turn Open	3/4 Turn Open	470734	470361	425495
JC	470451	HL-16B	1957	470322	470324	470448	1-1/4 Turn Open	3/4 Turn Open	470734	470361	425495
600	470171	HL-22A	1959	470322	470325	470350	1-1/4 Turn Open	3/4 Turn Open	470734	470361	425495
600A	470171	HL-22A	1960	470322	470325	470350	1-1/4 Turn Open	3/4 Turn Open	470734	470361	425495
610	470171	HL-22A	1960	470322	470325	470350	1-1/4 Turn Open	3/4 Turn Open	470734	470361	425495
400	Use 470732	1-PA	1959	470639	470640	470647	3/4-1 Turn Open	1 to 1-1/8 Turn Open	470644	470645	426599
400A	Use 470732	1-PA	1960	470639	470640	470647	3/4-1 Turn Open	1 to 1-1/8 Turn Open	470644	470645	426599
410	470732	1-PA-Mod.	1960	470639	470640	470647	3/4-1 Turn Open	1 to 1-1/8 Turn Open	470644	470645	426599

FILTER FELT TEN PACK CARTONS

10 Pack Carton - Part No. 470683
(Contains Part No. 426563 for 400
Series engines)

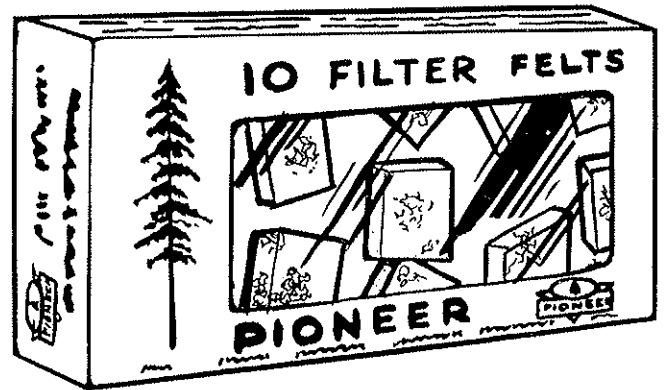

10 Pack Carton - Part No. 470460
(Contains Part No. 425670 for
Model RA and 600 Series engines)

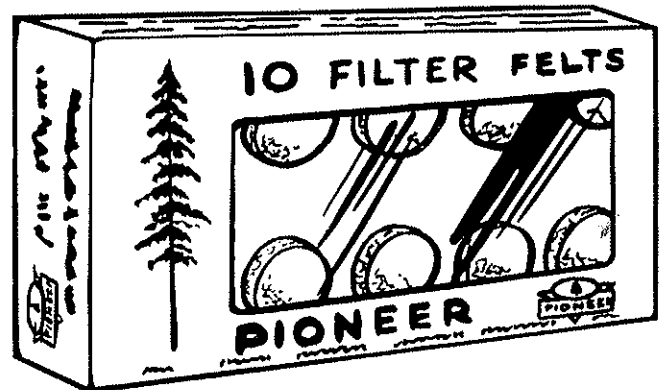

SPROCKETS

SIX PACK PACKAGE
PART NO. **470779**

(Contains Part No. 470340 Sprocket
and Drum Assembly. Standard ser-
vice replacement for all Direct Drive
Pioneer Saws.)

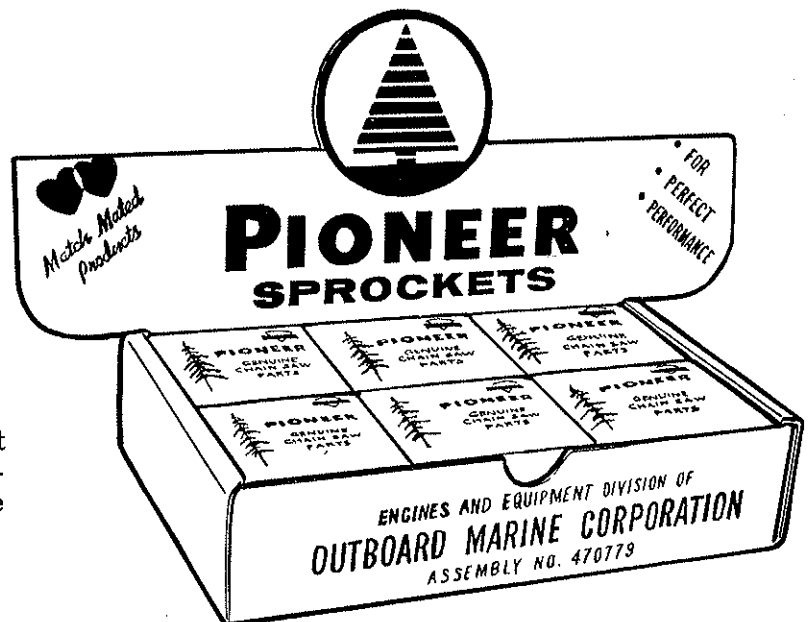

PIONEER SAWS

WAUKEGAN, ILLINOIS