



CLINTON



D50 HANDY

Illustrated Parts List AND INSTRUCTION MANUAL

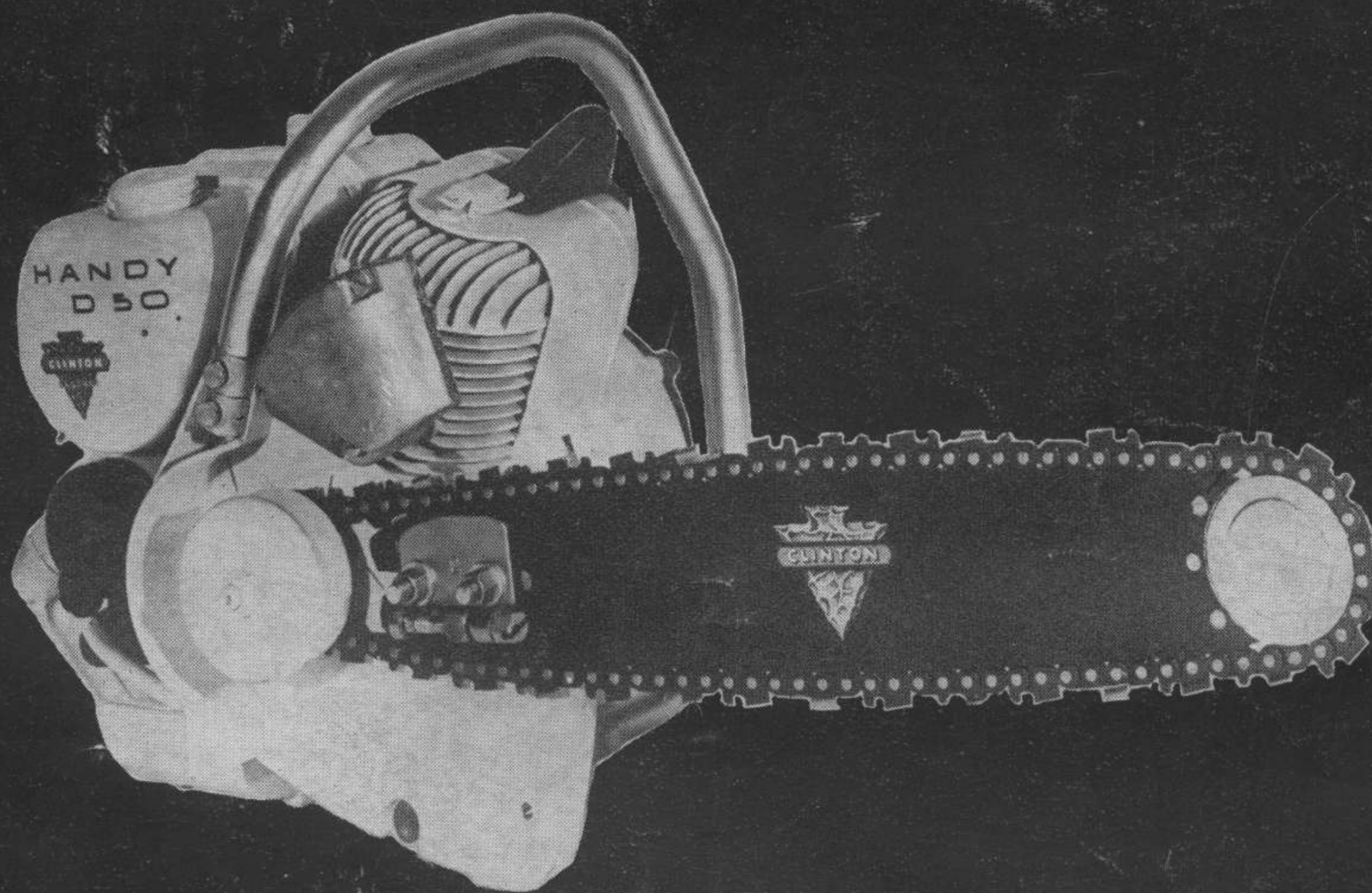

Clinton Engines Corporation

Chainsaw-Outboard Division

CLINTON, MICHIGAN

TABLE OF CONTENTS

INTRODUCTION AND GENERAL INFORMATION

Introduction	2	Fuel Preparation and Lubrication	5
Specifications	2	Chain and Guide Bar Lubrication	5
Principle of 2-Cycle Engine Operation	3	Safety Precautions	5
Assembly of Guide Bar and Chipper Chain	4	Break-In Period	5

STARTING AND OPERATING PROCEDURE

Controls	6	Notching and Felling Cut	8
Starting Procedure	7	Chain Maintenance and Filing Instructions	9
Carburetor	7	Guide Bar Maintenance	10
Bucking Cut — Small Logs	8	Service Tips	11
Bucking Cut — Large Logs	8	Helper's Handle	11

SERVICE AND ADJUSTMENTS

Fuel System	11	Maintenance	11
Magneto Assembly & Ignition	11	Unit Identification	12
Cleaning Valve Ports — Exhaust	11	Illustrated Parts Section	12-27

INTRODUCTION

By following the instructions in this manual you can look forward to dependable service from your Chainsaw. Quality made, time tested your Chainsaw is designed to provide efficient cutting on a great variety of jobs. It is checked for high standards during all phases of production and assembly. Treat your Chainsaw right, and it will become the most valuable tool you own.

For periodic servicing and all major repairs, you should consult the Authorized Clinton Service Station in your

area. Here you will find factory-trained mechanics, genuine parts and prompt, efficient service at your disposal. There are Clinton Service Stations throughout the United States, Canada and many foreign countries. Consult the yellow pages of your telephone directory for list of Authorized Clinton Service Stations.

For additional information about your Chainsaw please feel free to write directly to the factory.

SPECIFICATIONS

ENGINE — Clinton two cycle, one cylinder, air-cooled.

BORE — 1 $\frac{7}{8}$ ".

STROKE — 1 $\frac{5}{8}$ ".

FUEL — Oil and Gasoline mixed.

SPARKPLUG — Champion H 10J or equal, Gap .025 inches.

POINT GAP — .020 inches, nominal setting.

IGNITION TIMING — Fixed.

TYPE OF VALVE — Reed.

IDLING SPEED — Approximately 1500 to 1800 R.P.M.

TYPE OF BEARINGS — Needle.

OPERATING SPEED — App. 4800 R.P.M.

TYPE OF CARBURETOR — Diaphragm.

FUEL TANK CAPACITY — 1 qt.

FUEL RATIO — $\frac{3}{4}$ pint of SAE #40 to 1 gal. gasoline.

RECOMMENDED GASOLINE — Any good grade (non-leaded).

RECOMMENDED OIL GRADE — SAE #40 (non-detergent)

TYPE OF IGNITION — High tension flywheel magneto.

TYPE OF STARTER — Recoil.

TYPE OF CLUTCH — Automatic Centrifugal.

CHAIN OILER CAPACITY — One pint SAE #40

GUIDE BAR LENGTHS — From 16 inches to 26 inches.

OPERATION OF THE TWO CYCLE ENGINE

In a two cycle engine, intake, compression, power and exhaust are completed in two strokes of the piston. A power stroke results with every revolution of the crankshaft. On the upward stroke of the piston, a partial vacuum is created in the crankcase. (See Figure No. 1)

First, the vacuum and outside air pressure cause the reed valve between the crankcase and the carburetor to open. The air-fuel mixture from the carburetor flows in to the engine crankcase. Then, the downward movement of the piston causes the reed valve to close while continued downward movement of the piston compresses the fuel charge in the crankcase. Near the bottom of its stroke the piston uncovers the intake by-pass port, which connects the combustion chamber and the crankcase.

As the piston moves upward on its stroke, it passes the intake port, closing the port opening. Its continued upward movement causes the fuel mixture in the cylinder to be compressed. At the same time a new fuel charge is drawn into the crankcase. As the piston nears the top of the compression stroke, the fuel mixture in the combustion chamber is ignited by the spark. The explosion and expansion of gases forces the piston down on its power stroke. Power is not delivered for the full length of the stroke. Some time is required to rid the cylinder of burned gases, so that it may receive a fresh fuel charge from the crankcase.

As the piston nears the bottom of its stroke, it uncovers the exhaust port opening slightly ahead of the intake port. This permits taking advantage of the pressure of the exhaust gases in the cylinder, which are still comparatively high, and allows them to start escaping. Further downward travel of the piston uncovers the intake by-pass port. The incoming charge assists in forcing the exhaust gases out of the cylinder, to complete the cycle.

The chief attributes of the two cycle engine are its lightweight, low cost and powerful but simple operation. With only three basic moving parts (crankshaft, piston and rod), maintenance costs are at a minimum while efficiency is at a maximum.

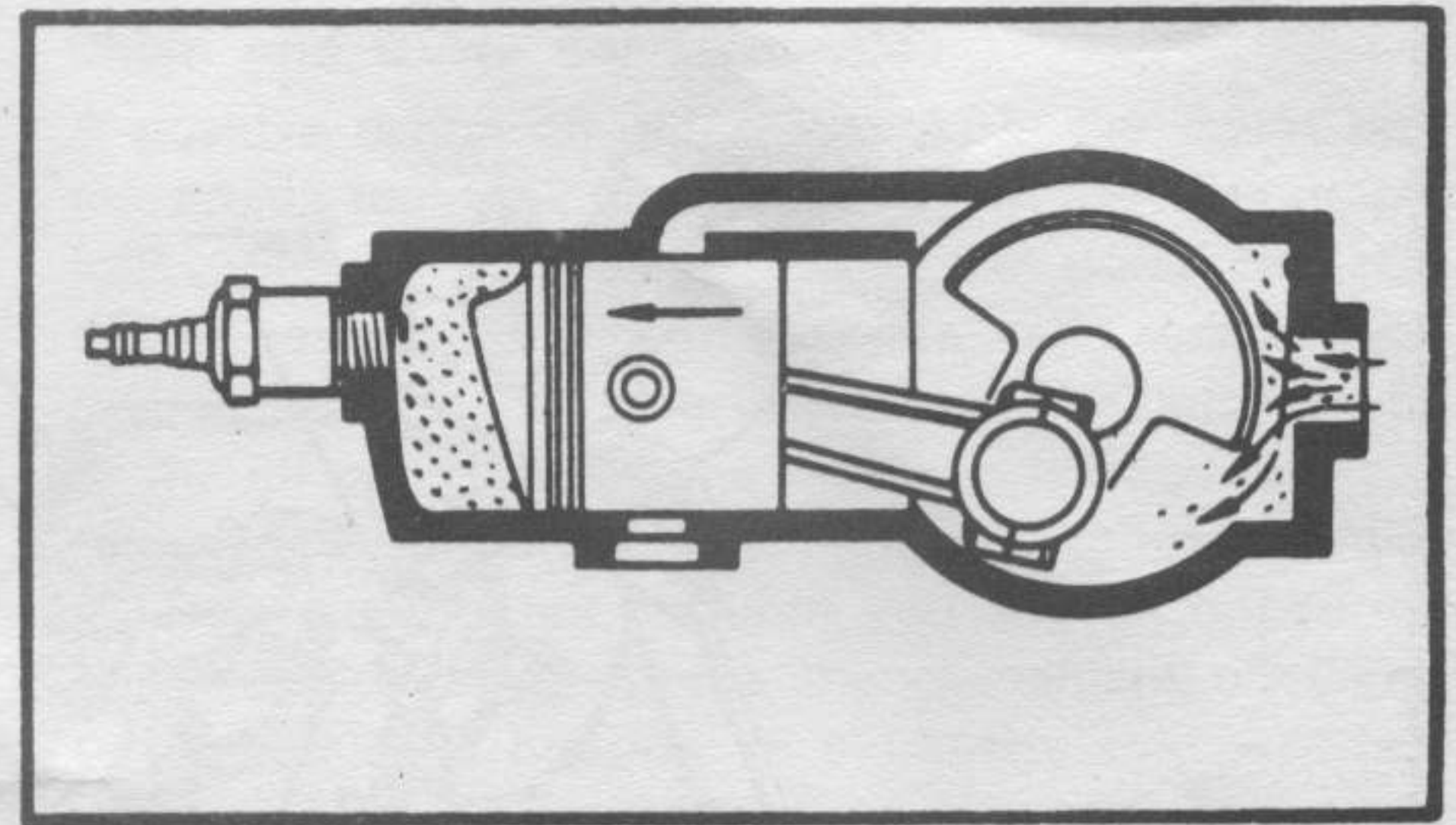

COMPRESSION

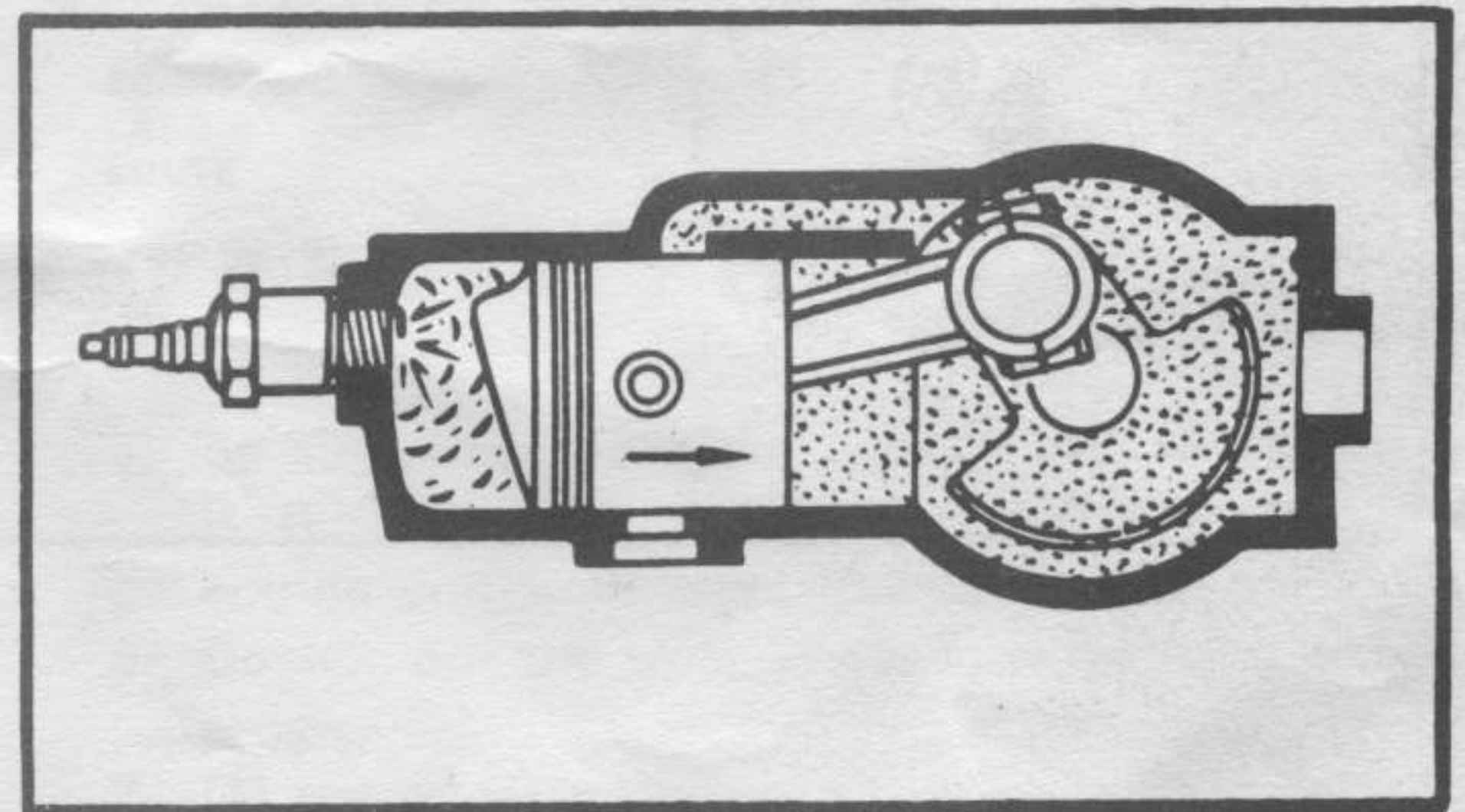

POWER

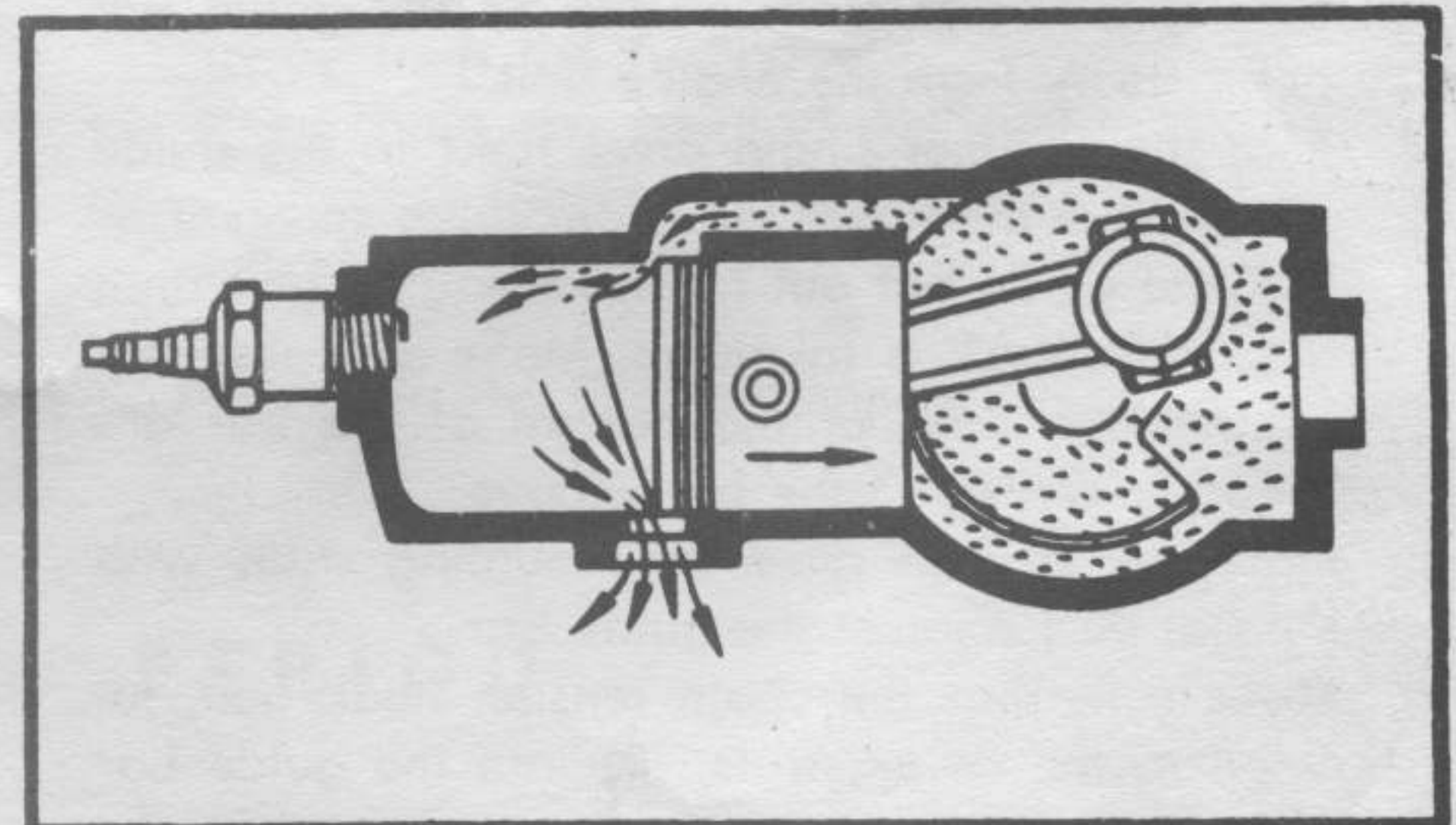

EXHAUST

Figure No. 1

ASSEMBLY OF GUIDE BAR AND CHIPPER CHAIN

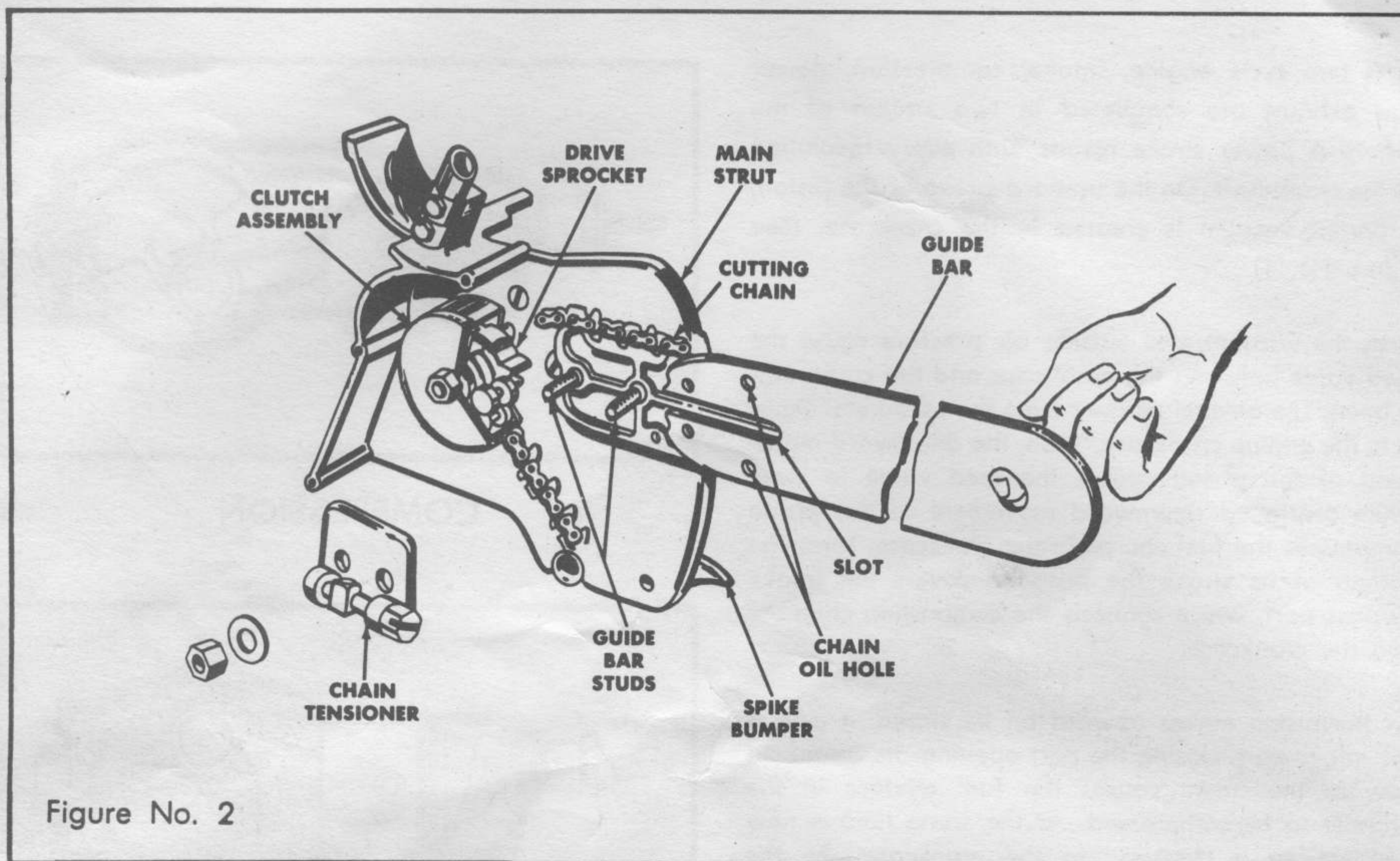

Figure No. 2

1. Slide the guide bar over the mounting studs on the reduction housing to the full length of the guide bar slot. (See Figure No. 2)
2. Place the chain around the guide bar so that cutting edges of teeth on top of the guide bar point away from the engine unit.
3. Seat the Chipper Chain drive links in the guide bar groove then over the chain drive sprocket.
4. Pull the guide bar out from the engine unit until the chain slack is taken up. Make sure that the chain drive links at the bottom of the bar are properly seated in the bar groove.
5. Place the tension plate on mounting studs with the flat pad against the guide bar.
6. Make sure that the chain tension hook bolt, located in the cover struts, fits into the guide bar slot.
7. Place the spike bumper over the studs on the reduction housing and secure with nuts.
8. Put washers and nuts on the guide bar mounting studs to make them snug, but not tight, against the guide bar mounting plate.
9. While holding with upward pressure of the finger

in the hole at end of guide bar, turn tension adjusting screw on the hook bolt clockwise until the chain has a free sag of not less than $\frac{1}{8}$ inch nor more than $\frac{1}{4}$ inch from the bottom of the guide bar. If the blade is not in the up position as high as it will go against the guide bar studs, it will cause excessive wear on the top of the guide bar closest to the sprocket.

10. Securely tighten the mounting stud nuts and then re-check for proper chain tension. If the tension has changed, then loosen the mounting stud nuts and repeat the procedure outlined in step 9.
11. Be sure the chain is properly tensioned at all times. Check it often. A chain that is too tight will interfere with proper cutting and will cause serious damage to the guide bar and the engine. CAUTION: Check and maintain chain tension for long life and best operation. Use extra care with a new chain until the stretch, which is most noticeable in the first hour of cutting, is eliminated.

CAUTION — Never Adjust Chain Tension While Engine Is Running.

FUEL PREPARATION AND LUBRICATION

Correct fuel mixture is one of the most important points in operating your engine. Follow these instructions carefully, and **DO NOT POUR UNMIXED GASOLINE OR OIL INTO THE FUEL TANK.**

Type of Oil

Use SAE #30 motor oil (non-detergent), such as Mobil-oil or a comparable straight mineral oil. A detergent oil or oil containing additives is not advised.

Type of Gasoline

A good grade of regular gasoline, available at your local filling station, is recommended for use in your chain saw engine. High octane or leaded fuels offer no advantages and **ARE NOT** advised.

Mixing Ratio of Oil to Gasoline

Thoroughly mix $\frac{3}{4}$ pint of oil with each gallon of gasoline. This rich oil mixture may cause difficulty

with idling, but it is necessary to properly wear in the various parts of the engine.

Chain and Guide Bar Lubrication

A positive action oil pump located in the lower portion of the fuel tank (See Figure No. 3) provides ample lubrication to the cutting chain and guide bar. Fill this oil reservoir with SAE #30 oil, being sure to keep the oil level in the reservoir above the intake tube of the oil pump. When the reservoir is filled and cap replaced, push the oil pump plunger a couple of times until pressure is felt, or until you see oil appearing on the guide bar opposite the convenient oil fitting in the reduction housing. In extremely cold weather, or when cutting wood which contains a lot of pitch, sap or resin, use a 50-50 mixture of kerosene and oil in the oil reservoir. This will provide good lubrication as well as keeping the guide bar groove and chain comparatively clean.

SAFETY AND FIRE PRECAUTIONS

Your Chainsaw is well-built for maximum safety and efficiency, but carelessness in operation can cause accidents. Read the following suggestions carefully, and remember them as you work with your saw.

1. Do not start the engine in a closed room. Have ample ventilation at all times.
2. Do not touch the chain when the engine is running even at a slow speed.
3. Keep engine adjusted to an idle speed which stops the chain completely.
4. Do not move the chain from one location to another without first stopping the engine.
5. Be sure that the spike bumper (abutment strut) is flush against the sawing log to keep the engine unit from being pulled against the log.
6. Do not operate your chain saw when it needs repair.
7. Do not allow the saw to run while on a cement floor.
8. Do not run saw when it is dull or improperly filed.
9. After refueling, move the engine a few feet away from the fueling site.
10. Keep chain saw clean of dust and inflammables, and check to see that spark plug and electrical connections are tight.

Never Carry the Chain Saw from Place to Place with the Engine Running

BREAK-IN PERIOD

In order to obtain maximum efficiency and service from your chain saw, it is necessary that the engine be operated during a break-in period of approximately five (5) hours. Never operate the engine without load or allow it to become overheated. Proper breaking in of key parts will have much to do with

the life of your engine. Be sure to check often for loose nuts and screws and make all necessary adjustments. Periodic inspection and service by your authorized Clinton Service Station dealer will result in long life and good performance of your Chainsaw.

CHAIN SAW CONTROLS

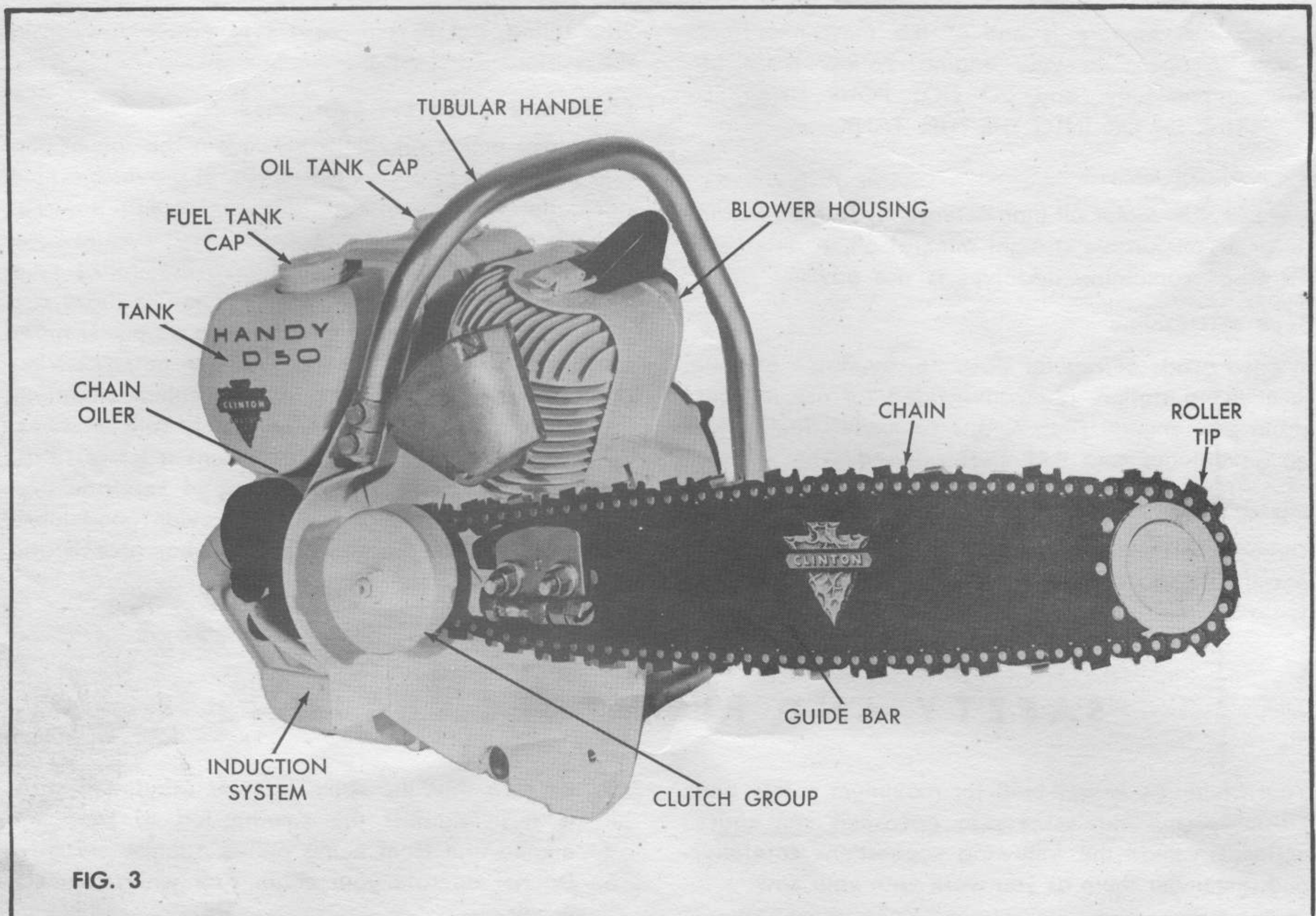

FIG. 3

Major controls on your chain saw are conveniently grouped around the hand grip assembly for finger tip action. You will find your saw easy to manage once you associate the following controls with their locations on the saw. (See Figure 3.)

THE RECOIL STARTER—Located on the left side of the unit. A slight pull will engage the starter with the engine and a spring disengages it when the tension is relieved. **CAUTION:** The starter cable when pulled out, should not be released abruptly and allowed to snap back into its socket. Release slowly to permit complete re-winding.

THE CHAIN OILER—Manually operated, plunger type oil pump, located in the lower portion of the fuel tank just above the hand grip. This system forces oil to the guide bar and chain for positive lubrication.

FUEL SHUT-OFF VALVE—On the bottom of the fuel tank at the lower right. To open, turn counter-clockwise until a slight tension is noticed.

THE THROTTLE CONTROL—Trigger-type, located on the handle grip. The engine speed, or throttle opening, is increased by squeezing the trigger upward into the handle.

THE HIGH SPEED MIXTURE ADJUSTMENT SCREW—Located on the left side of the carburetor. The adjustment is used to obtain proper fuel and air mixture, make the engine run smoothly and achieve maximum power.

THE IDLE FUEL MIXTURE ADJUSTMENT SCREW—This device is found on the left side of carburetor. It is used to obtain smooth and proper idling speed.

THE CHOKE LEVER—Located on the left side of the carburetor.

THE FUEL PUMP—Located on carburetor maintains proper fuel supply to the carburetor.

THE IGNITION SWITCH—Toggle-type, located directly under fuel tank.

STARTING PROCEDURE

ADJUSTMENT INSTRUCTIONS

To properly adjust carburetor for best performance the engine must be thoroughly warm.

INITIAL ADJUSTMENTS

To start a cold engine: First, carefully close by turning clockwise, both Idle and Main Adjustment Screws (Ref. 7 & 19)—located either below air intake opening or at left side of carburetor. Now open Main Adjustment Screw (Ref. 19) counterclockwise approximately one and one-quarter turns ($1\frac{1}{4}$). Open Idle Adjustment Screw (Ref. 7) three-quarters ($\frac{3}{4}$) turn. Back Idle Speed Regulator Screw off its contact with Throttle Stop Lever then turn it inward about one (1) full turn so as to slightly open Throttle Shutter (Ref. 11).

Open fuel shut off valve, choke carburetor, put ignition switch to "ON" position, squeeze throttle trigger and give firm quick pull on starting cord. When engine fires, decrease the choke slightly and ease off the

throttle trigger. Do not race engine, gradually decrease the choke to full open position as engine warms. Then make several test cuts and if necessary, to keep engine from stalling, slightly increase opening of the Main Adjustment Screw (Ref. 19).

FINAL ADJUSTMENTS

Now close throttle and readjust Idle Speed Regulating Screw so engine idle speed is at approximately 1800 to 2200 RPM and without chain turning or throttle trigger being depressed. Then, slowly readjust Idle Adjustment Screw (Ref. 7) to obtain smooth and even engine performance, after which enrichen the mixture slightly above this setting to provide sufficient fuel for quick acceleration. Finally, with saw functioning under a cutting load, slowly readjust Main Adjustment Screw (Ref. 19) to obtain even cutting speed. This setting will vary between one (1) to one and one-half ($1\frac{1}{2}$) turns open.

1. Fuel Inlet
2. Fuel Pump Body
3. Fuel Pump Diaphragm
- 3A Fuel Inlet Check Valve
- 3B Fuel Outlet Check Valve
4. Fuel Pump Gasket
5. Diaphragm Cover Gasket
6. Diaphragm Chamber
7. Idle Adjustment Screw
8. Impulse Channel
9. Idle Fuel Adjustment Orifice
- 10A Primary Idle Discharge Port
- 10B Secondary Idle Discharge Port
11. Throttle Shutter
12. Main Fuel Adjustment Orifice
13. Body
14. Venturi
15. Main Fuel Discharge Port
16. Choke Shutter
17. Fuel Inlet Supply Channel
18. Inlet Needle & Seat
19. Main Adjustment Screw
20. Inlet Tension Spring
21. Inlet Control Lever
22. Fulcrum Pin
23. Atmospheric Vent Hole
24. Diaphragm Cover
25. Diaphragm
26. Strainer Gasket
27. Fuel Inlet Screen
28. Strainer Cover Retaining Screw
29. Strainer Cover

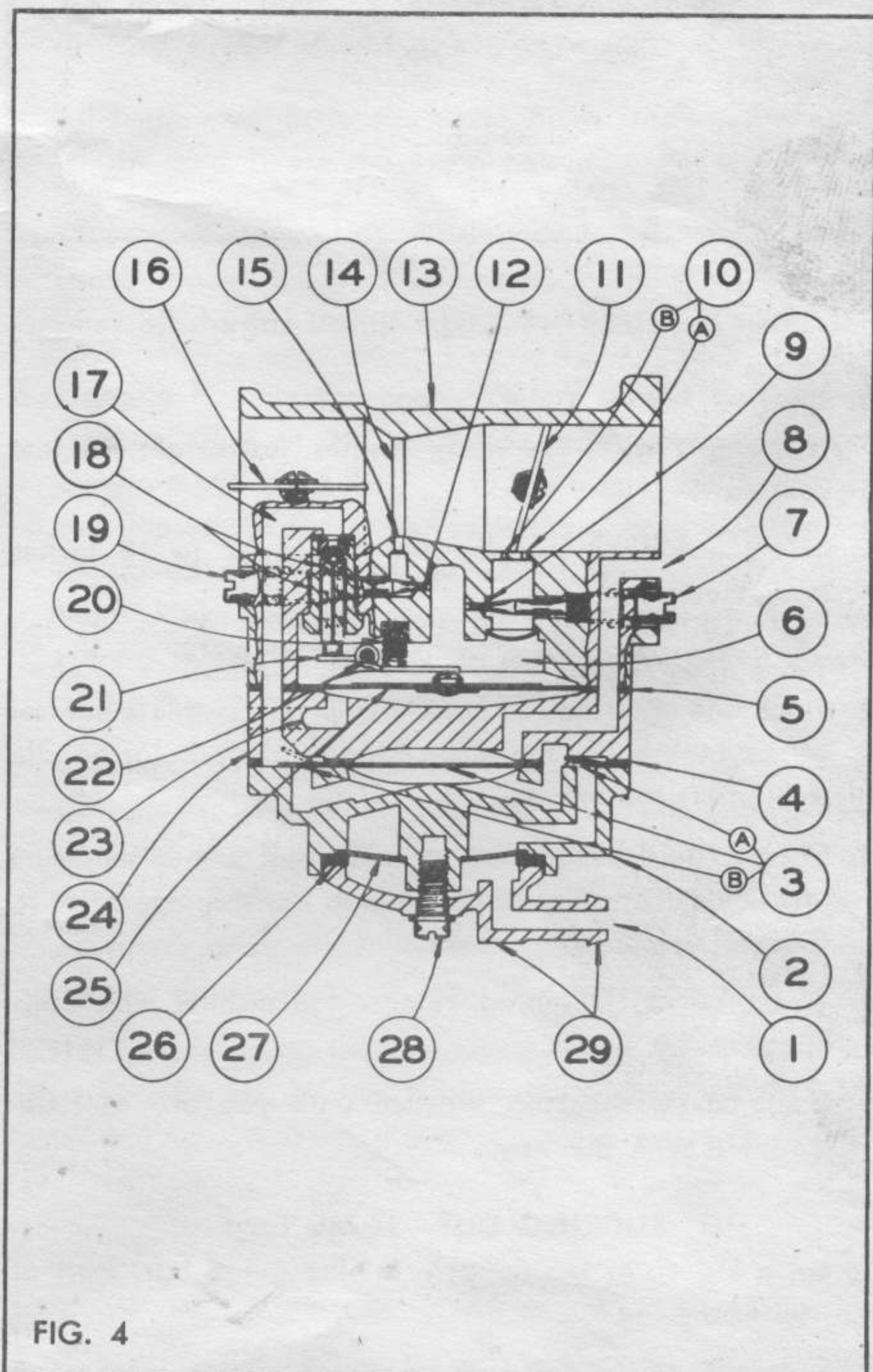



FIG. 5

BUCKING CUT — Small Logs

Try bucking a few stove wood lengths, just to get the feel of your saw.

1. Select a suitable log approximately 12 to 18 inches in diameter.
2. Start your saw according to instructions.
3. Place one hand on the handle grip for complete control of the engine. Use the other hand on the tubular handle to support the unit.
4. Chain should be allowed to feed itself with a minimum amount of pressure on the unit by the operator to achieve best cutting results.
5. As the cut is completed, release the throttle which disengages the clutch.
6. Continue this bucking practice until you are well acquainted with the saw.

BUCKING CUT — Large Logs

To cut a log up to the capacity of the guide bar, start at the top of the log.

1. Raise the power unit and lower the cutting mechanism to begin your cut on the side of the log that faces away from you.

2. Notice that sawing action holds the saw against the log. (See Figure No. 5).
3. After tilting the unit to the maximum angle (about 35°) for the initial cut, pull the chain saw toward you.
4. Repeat this rocking motion until the cut is completed.
5. CAUTION: As the cut nears completion you must be careful to keep the sawing unit from entering the ground. It is sometime possible to roll the log forward and complete the cut from the opposite side, but often this cannot be done, and extreme care is necessary.
6. Release the throttle as you complete the cut, and this action disengages the clutch.



FIG. 6

NOTCHING AND FELLING

For this type of operation rotate the guide bar in a horizontal position against the tree. DO NOT allow spectators within six feet of the chain when it is running.

1. Remember that the undercut notch guides the fall of the tree and should be made with care. By holding your saw at the desired angle any type of notch can be made, but plan carefully. (See Figure No. 6).
2. As you start your felling cut remember to LEAVE HOLDING WOOD (See Figure No. 6) or the tree might spin out of control.
3. Think before you cut!

CHAIN MAINTENANCE AND FILING INSTRUCTIONS

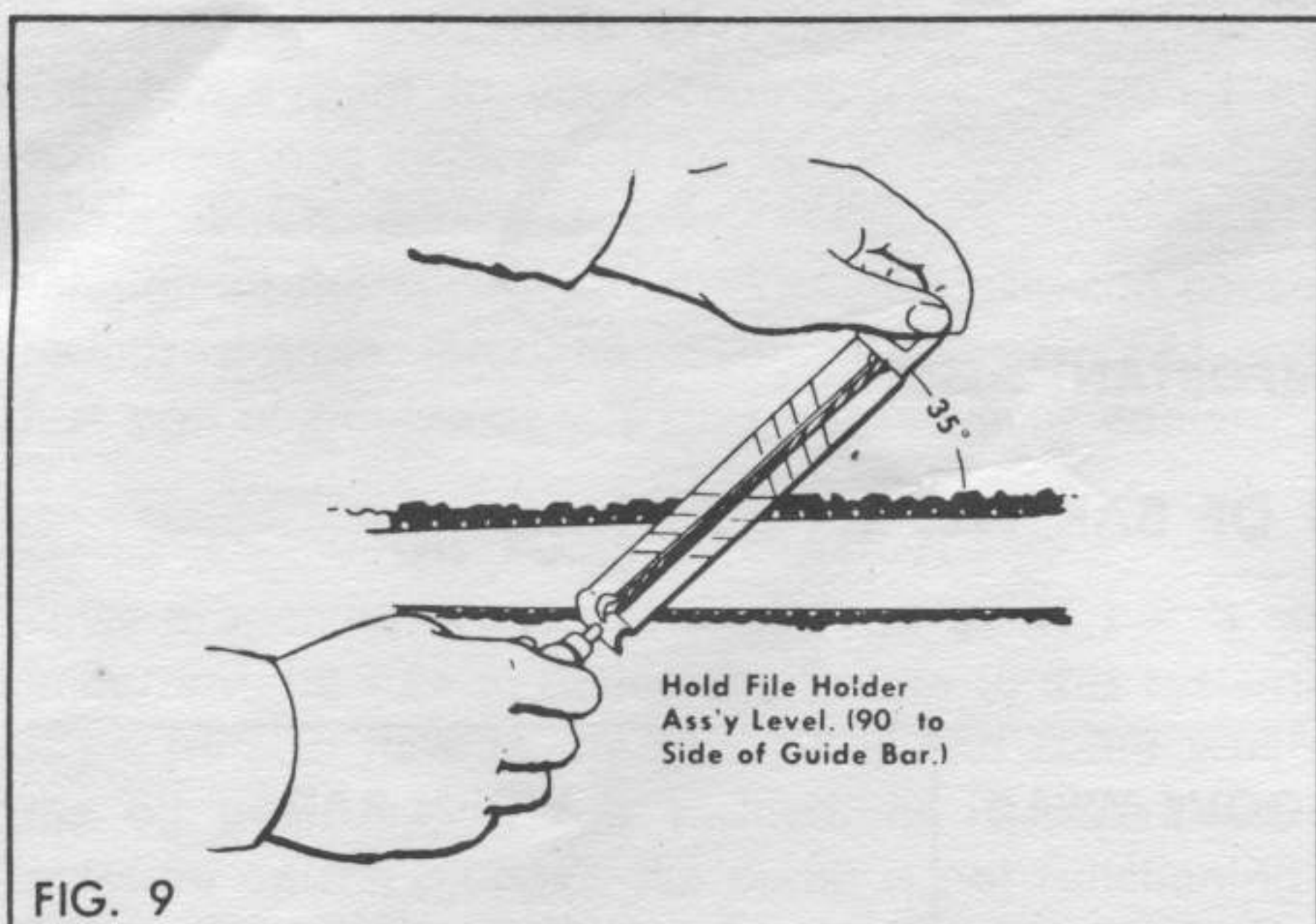

FIG. 9

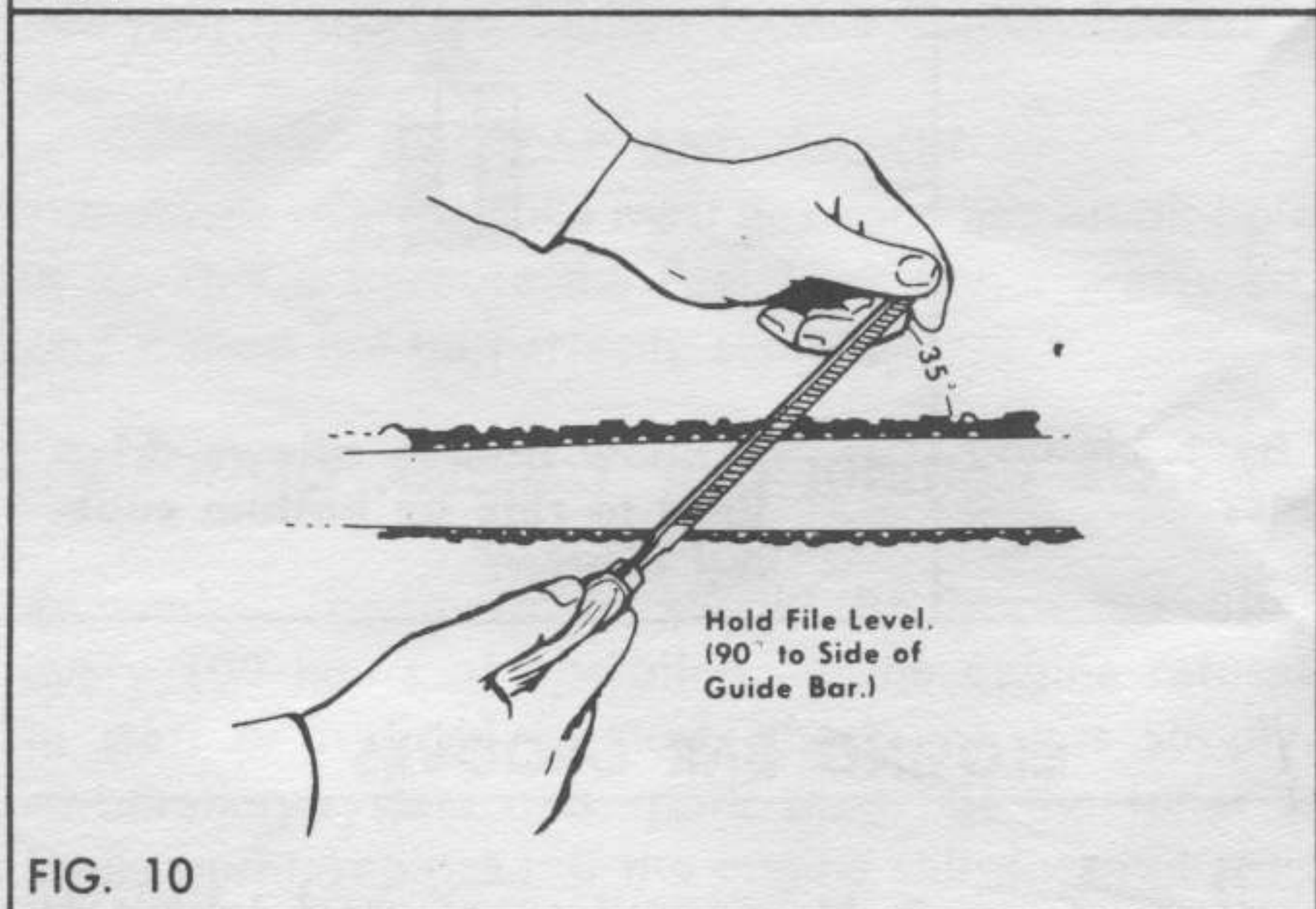

FIG. 10

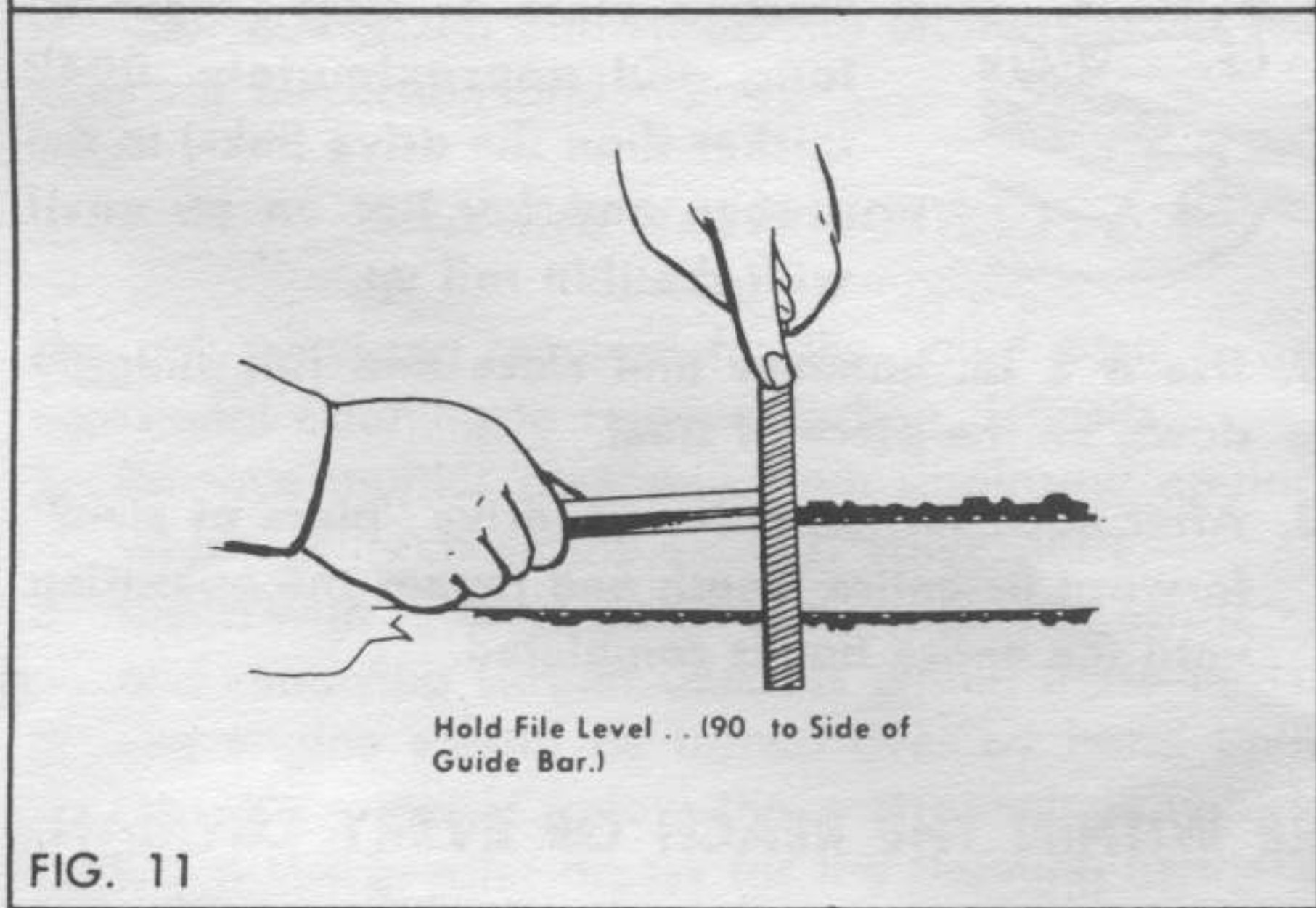

FIG. 11

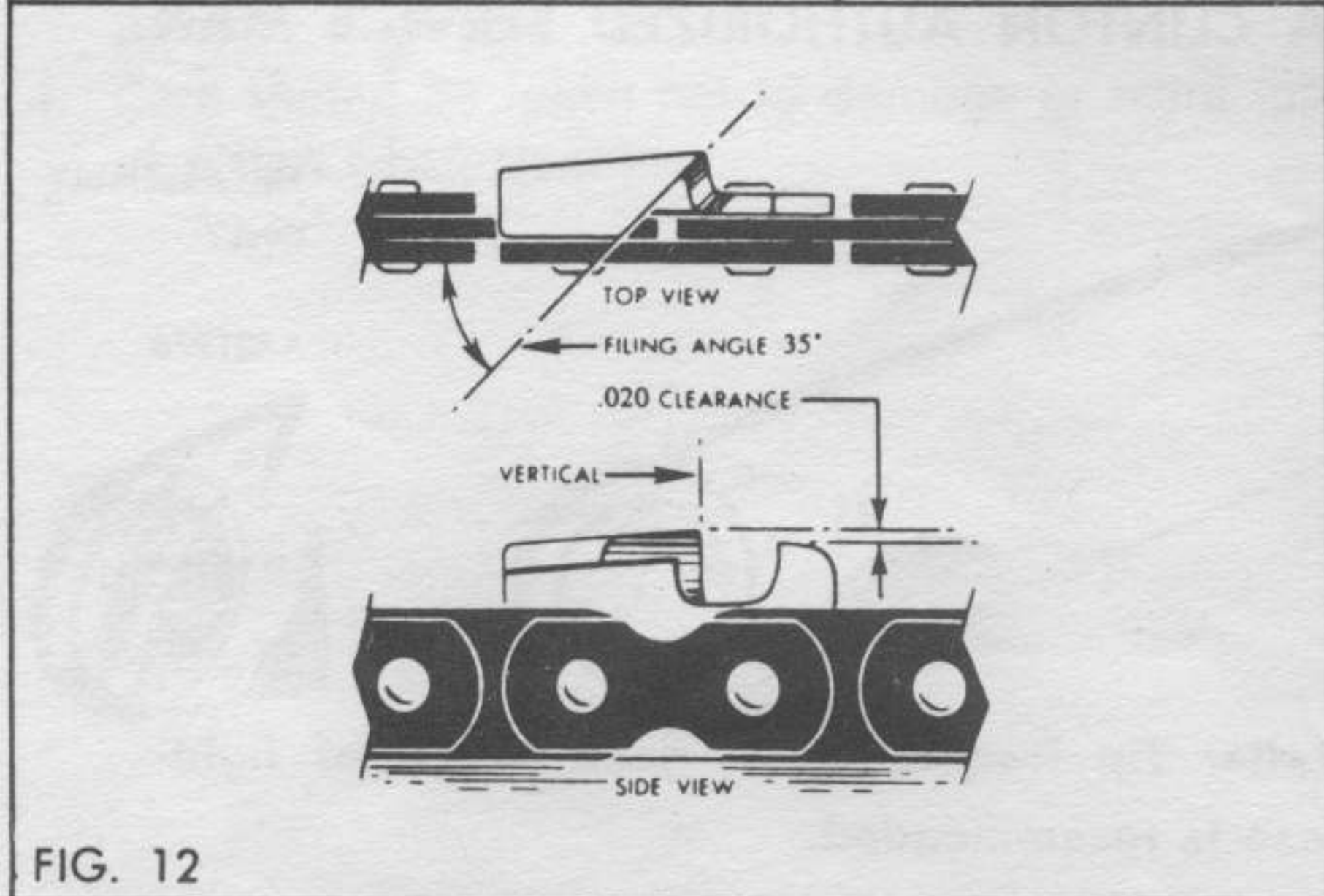

FIG. 12

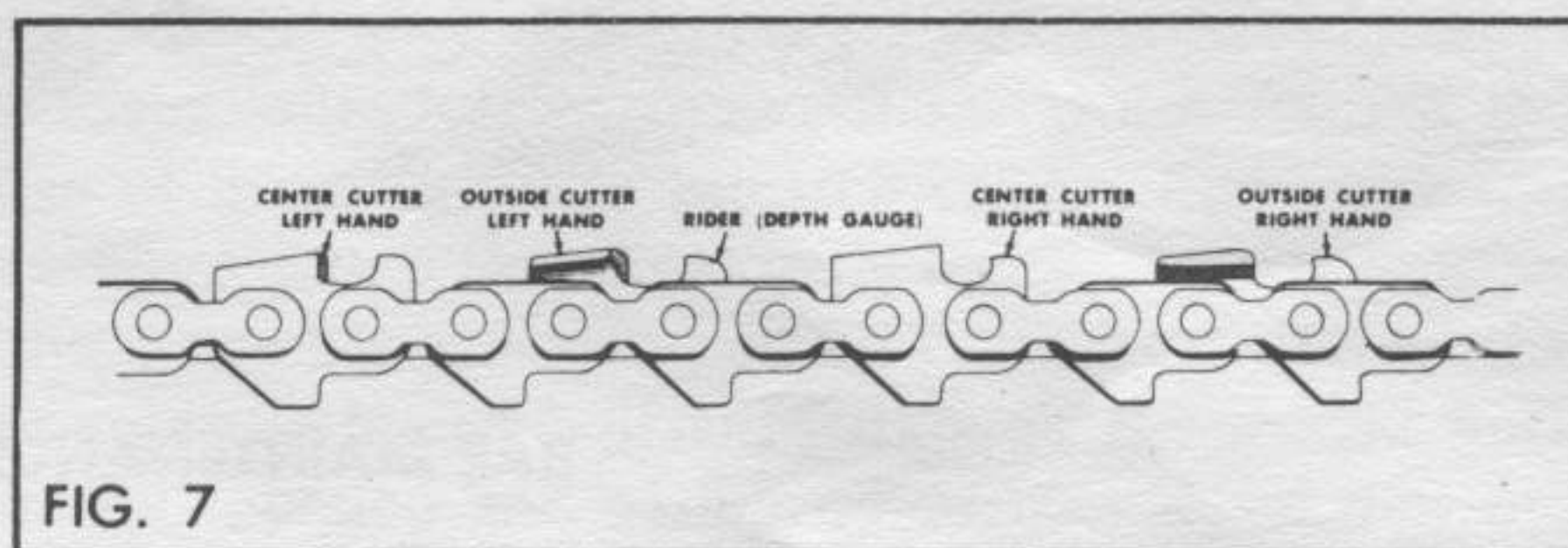

FIG. 7

1. Place chain in chain filing vise or straight edge vise if possible.
2. Place file holder assembly over rounded cutting tooth. (See Fig. 9) The left hand cutting tooth should be sharpened from the right side and the right hand tooth from the left hand side. Line up filing angle marks on holder with guide bar. Hold file level or 90° to the guide bar.
3. Two or three firm strokes (with pressure applied on the forward stroke) should give a keen edge to the tooth.
4. All teeth must have the same filing angles, the same length, and riders the same height.
5. The center cutters, located between the curved cutting teeth, should be filed with a flat file (See Fig. 10) after all the curved cutting teeth have been filed.
6. Using a flat file the center cutters should be filed on leading edge at 35° angle or at the same angle as cutting teeth. Hold file 90° to the guide bar. Take care that the top of the center cutters are even with the top of curved cutting teeth or .005 below curved cutting teeth. Make sure that they are never above the curved cutting teeth. When finished the center cutters should all be the same length and height.
7. The final step is to file the riders down. This is done with the use of a depth gauge (See Fig. 11). Care should be taken that all riders have the same height and that the leading edge is rounded off after filing. Set riders on direct drive chain saws at .025. Set riders on reduction drive models at .035. See picture.

NOTE: In soft wood, the saw chain depth riders on direct drive may be set at .035 on reduction drive at .045 for faster cutting.

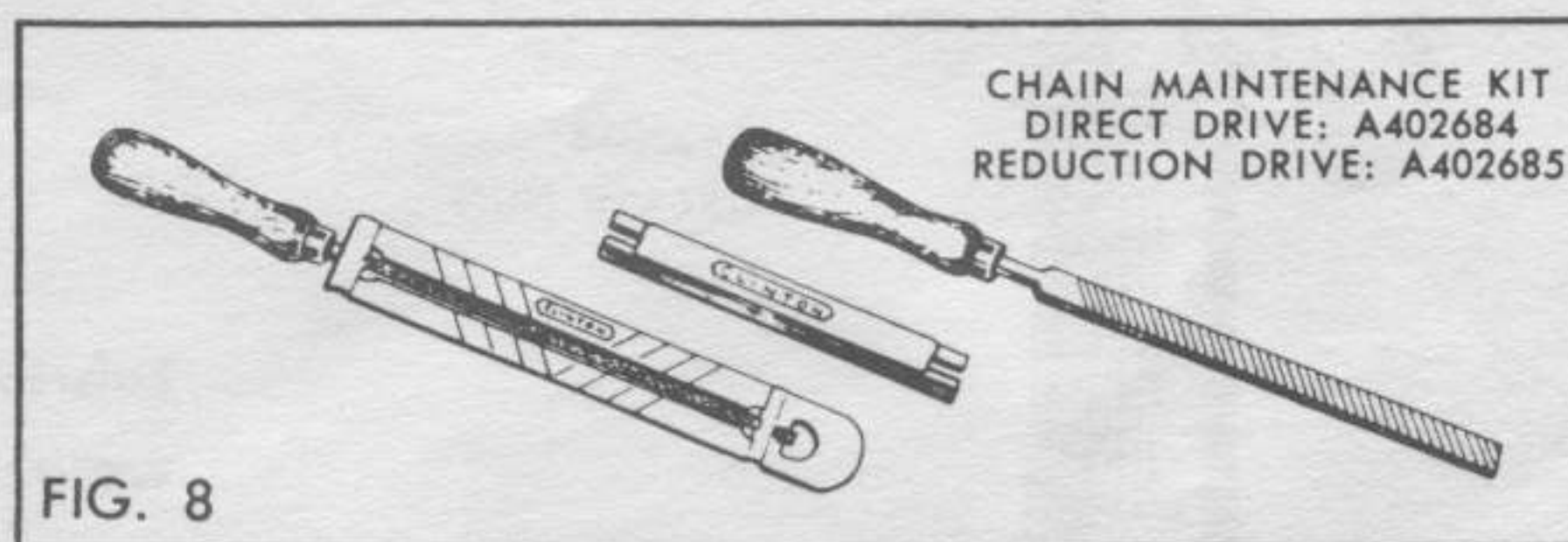



FIG. 8

BAR MAINTENANCE



BAR MAINTENANCE IS IMPORTANT ALSO.

THREE MAJOR FORMS OF BAR WEAR

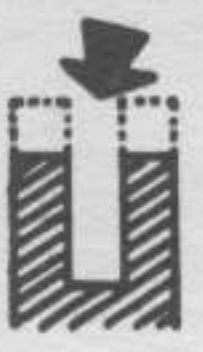
1	2	3
<p>UNEVEN RAIL WEAR</p>  <p>Causes cut to bend or "run" . . . chain to bind in cut.</p>	<p>UNEVEN INSIDE GROOVE WEAR</p>  <p>Causes friction and heat binding and general inefficiency.</p>	<p>WORN RAILS</p>  <p>Shallow groove allows drive links to ride on bottom causing chatter.</p>

JOINTING BAR RAILS



Jointing is the process of making the two rails level and square with each other so as to provide proper bearing surfaces for the bottoms of the tie straps and cutters.

Jointing should be done by your dealer whose shop is equipped to render this service. You can make temporary repair by using the flat file A401906 to even the rails.

CLOSING BAR GROOVES



1. Place a piece of steel (about 6" long and approximately .004" thicker than the drive links) in the groove and lay bar on an anvil with the thin rail up.

2. Use a 3 lb. hammer and close thin rail snugly down on the piece of steel.

3. After each section is closed, drive "piece of steel" forward its entire length and repeat the operation until the entire bar is completed.

BAR MAINTENANCE DUTIES DESCRIBED ABOVE ARE WITHIN THE REACH OF EVERY LAYMAN. ADDITIONAL DUTIES SHOULD BE HANDLED BY A CLINTON AUTHORIZED SERVICE MAN.

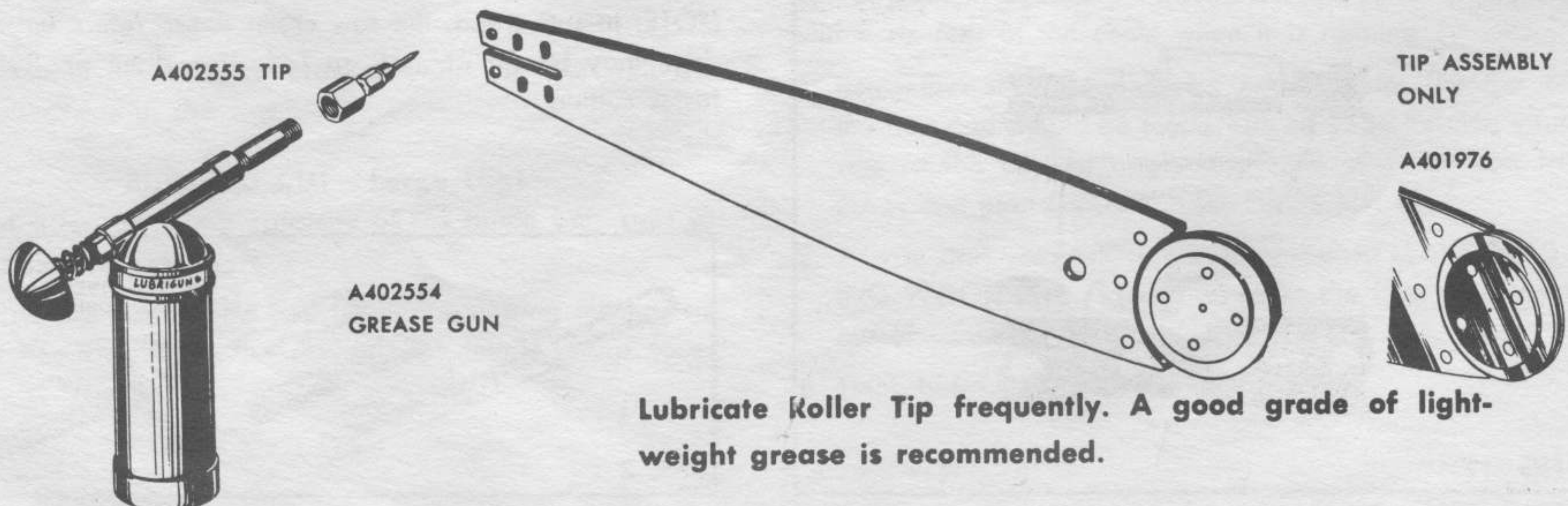

A402555 TIP

A402554
GREASE GUN

TIP ASSEMBLY
ONLY

A401976

Lubricate Roller Tip frequently. A good grade of light-weight grease is recommended.

SERVICE TIPS

FUEL SYSTEM

The fuel system in your Chainsaw is composed of fuel lines and orifices. It utilizes an automatic fuel pump which puts the proper mixture into action throughout the system. Fuel system defects can cause serious trouble throughout your Chainsaw. At the first sign of trouble of this kind, consult your dealer.

OIL PUMP OPERATION

Since proper lubrication of chain and guide bar is so important, be sure to notice any failure in this system. If oil fails to flow to the guide bar and chain when the oil pump plunger is pushed, or if there is no pressure on the plunger, the pump is not functioning. See your authorized Clinton Service Station Dealer.

GAS CAP AND GASKET

The plastic filler cap like most gas caps has an air-hole in it. This is because the Fuel Tank is not pressured, and it must not be perfectly sealed.

MAGNETO ASSEMBLY AND IGNITION SYSTEM (Flywheel Type)

Remember the magneto should be inspected after every 100 hours of operation. If the engine refuses to start or is hard to start, check the gas supply, carburetion system and spark plug. (If the latter is badly burnt, replace.) If the engine still does not start see your authorized Clinton Service Station Dealer for magneto inspection and repair.

CLEANING VALVE PORTS Exhaust

The only servicing required for the valve ports is an occasional cleaning to remove carbon deposits.

1. Remove muffler assembly from Chainsaw engine which will expose the exhaust valve ports.
2. Clean with suitable instrument capable of scraping and removing carbon deposits within these ports.
3. The engine should be turned over by hand until the piston moves below the port openings, which will allow greater access for the cleaning of these ports.
4. Care should be taken not to damage or score top of piston when cleaning.

HELPERS HANDLE

For specialized sawing operations which require the use of the long guide bar, the Clinton Chainsaw can be fitted with a Helpers Handle for two-man use.

This assembly is in two parts. A mounting stud on the handle-and-guard half slips through the slotted hole in the rounded end of the guide bar. Note that the lugs on either side of the mounting stud engage the slot to position the handle securely. The cover half is then placed over the stud and secured with a washer and wing nut.

MAINTENANCE

By making the following practices a habit you can help keep your saw in good running order and avoid repairs that neglect might make necessary.

1. Remove sawdust and dirt daily so that a thorough inspection can be made.
2. Tighten any loose nuts or screws.
3. Check fuel and oil lines for leaks, especially at connection points.
4. Check air filter and brush off dirt.
5. Do not use compressed air to remove dust or dirt from the OUTSIDE of the carburetor, since particles may be blown into the mechanism if you do.
6. Check muffler and exhaust ports periodically, when the loss of power is apparent. If ports are dirty, clean them.
7. As often as necessary remove the cutting chain from the guide bar and allow it to soak overnight in a pan of kerosene to remove the sap and resin deposits and to provide lubrication for all parts of the chain.
8. If you notice symptoms of trouble but cannot find the cause, check with your authorized Clinton Service Station, and be sure your saw is in good running order.

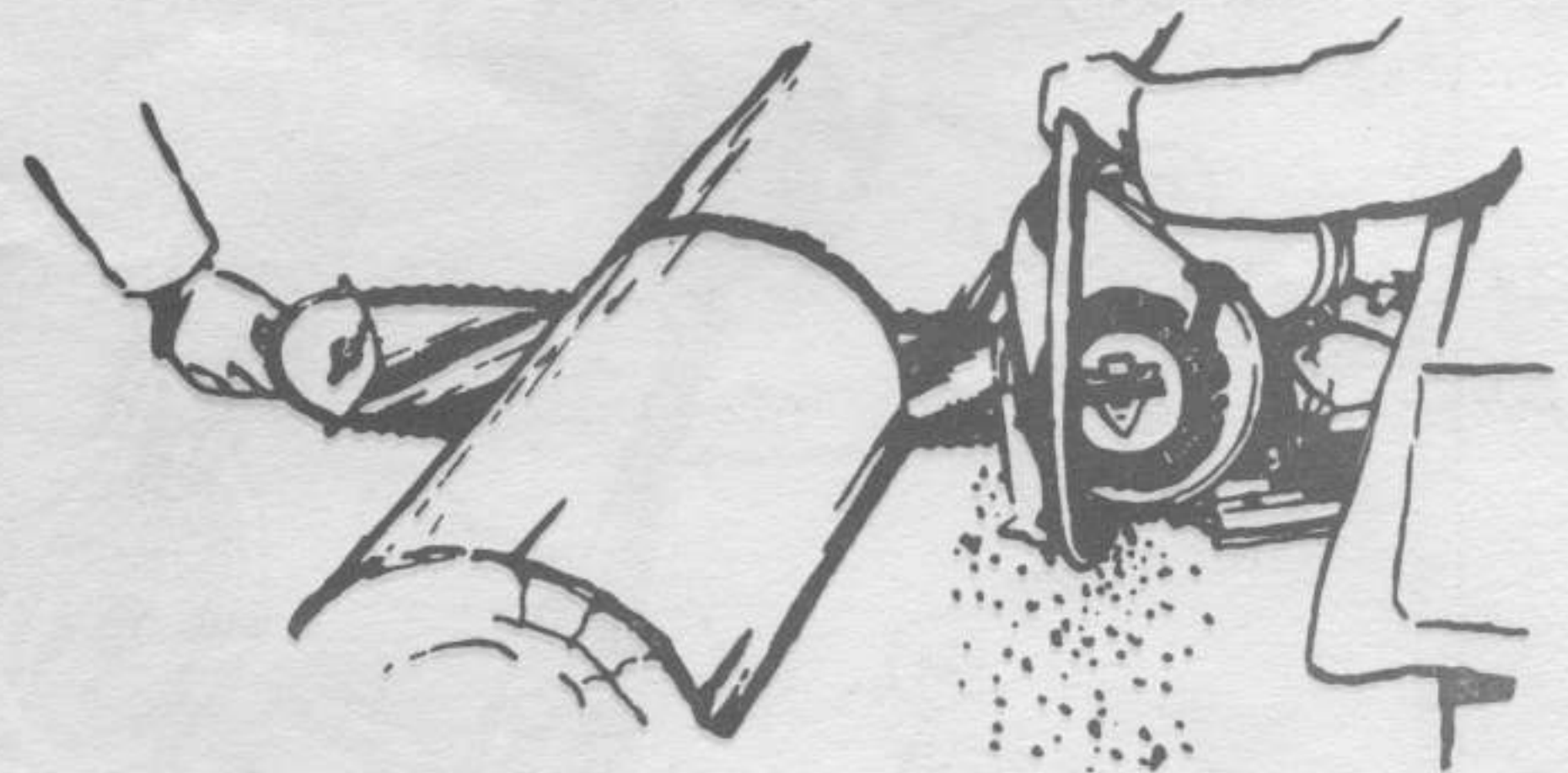

CHAINSAWS

HOW TO IDENTIFY

Each Digit in the Six Digit "TYPE" number stamped on the nameplate of your Chainsaw refers to a **Specific Type of Assembly** for each of the SIX Sub-Assemblies making up the complete Chainsaw. For example: **Type 57-15-50-0-40-21** is made up of a Type 57 Power Head, a Type 15 Tank Ass'y, a Type 50 Induction Ass'y etc. The illustrated Parts List for All Types of each Digit is found in the Parts Section. Identify the parts or assembly in which you are interested and find the part number in one of the Parts Lists making sure you have the right part number for the **TYPE** of Sub-Assembly used on your Chainsaw. **ALWAYS ORDER BY PART NUMBER.**

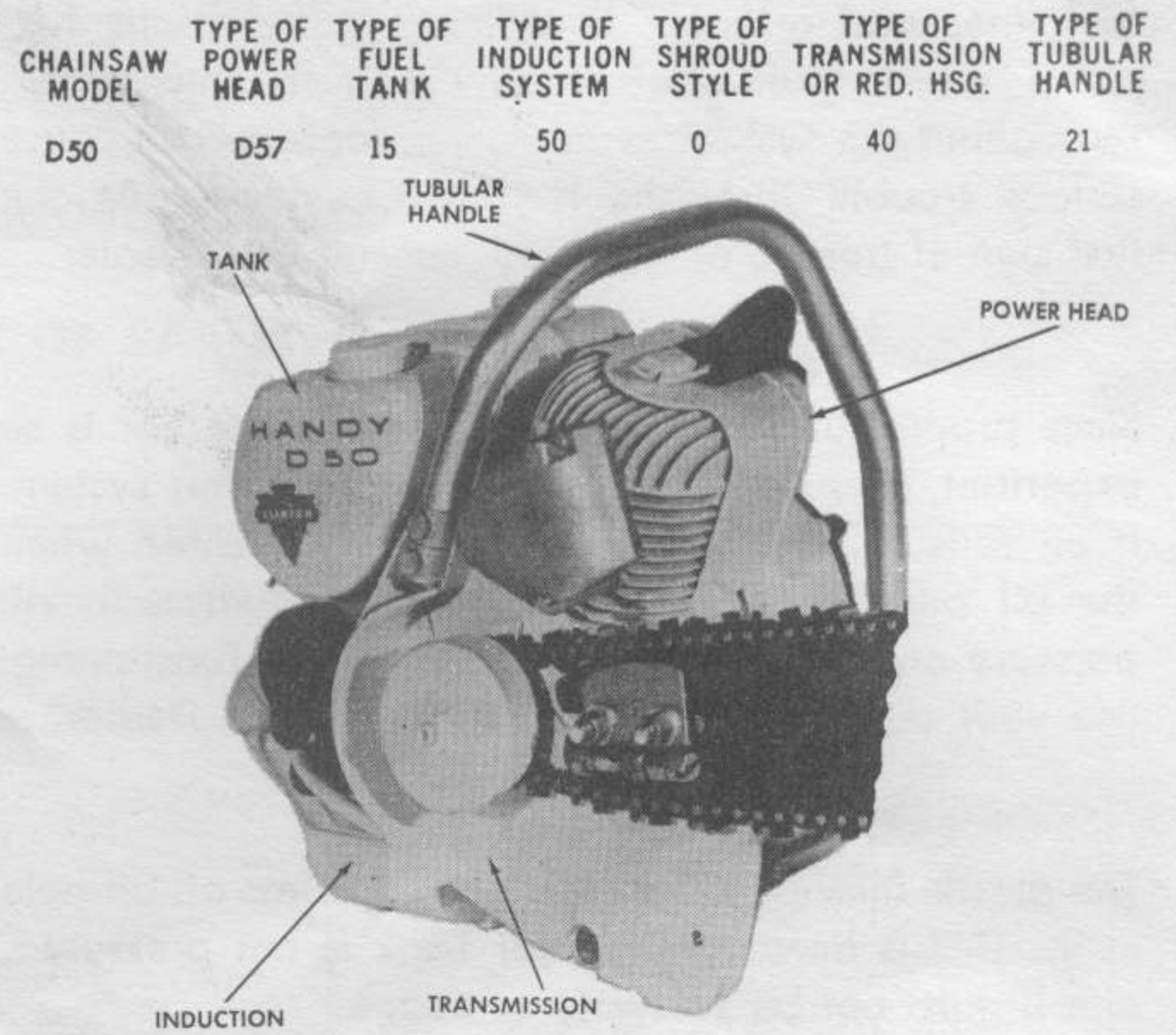

FIRST DIGIT — POWERHEADS

NOTE: The Powerhead is indicated by the first digit in the six digit Chainsaw Type Number found on the name plate.

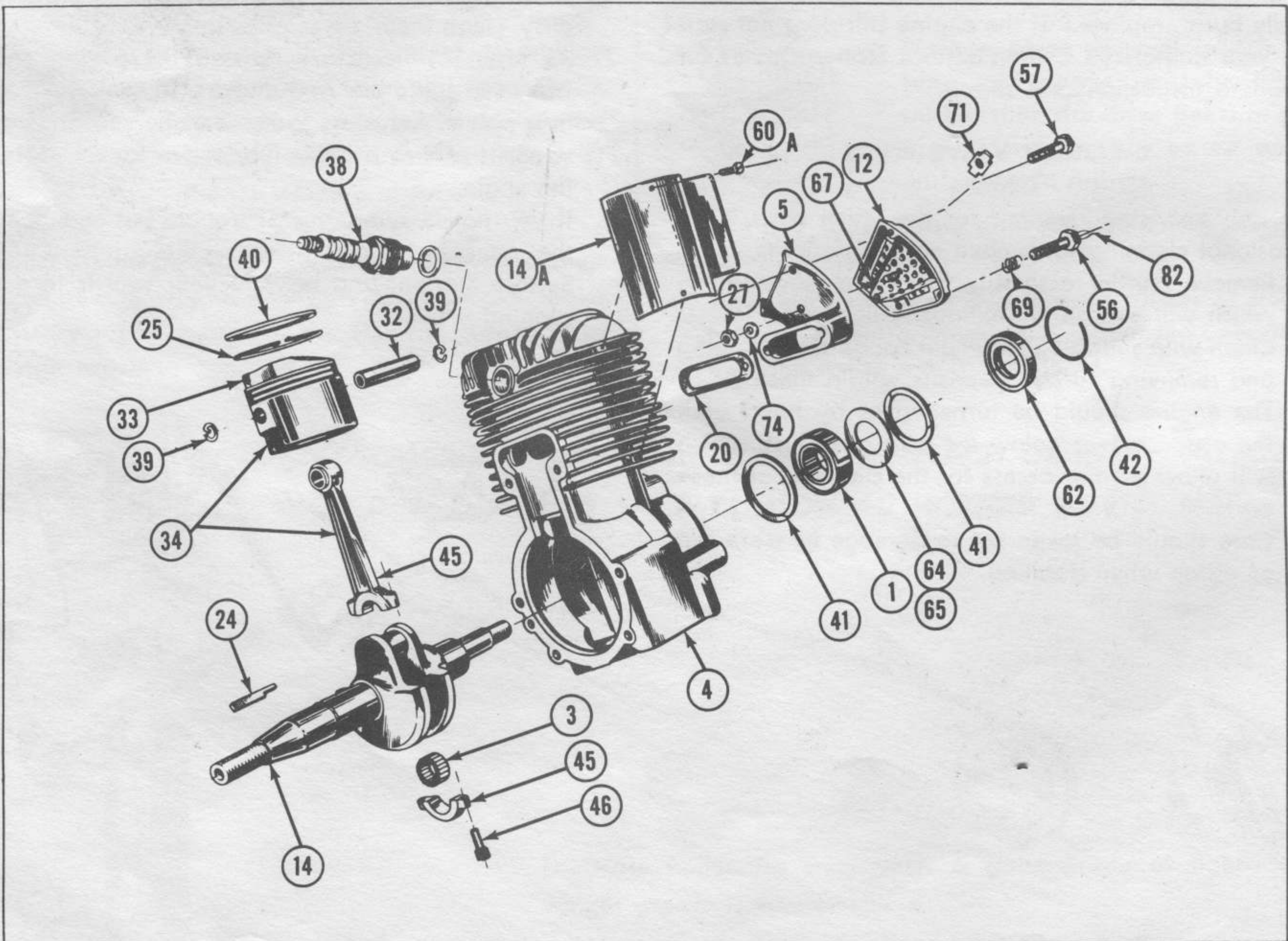

FIRST DIGIT — POWERHEADS

NOTE: The Powerhead is indicated by the first digit in the six digit Chainsaw Type Number found on the name plate.

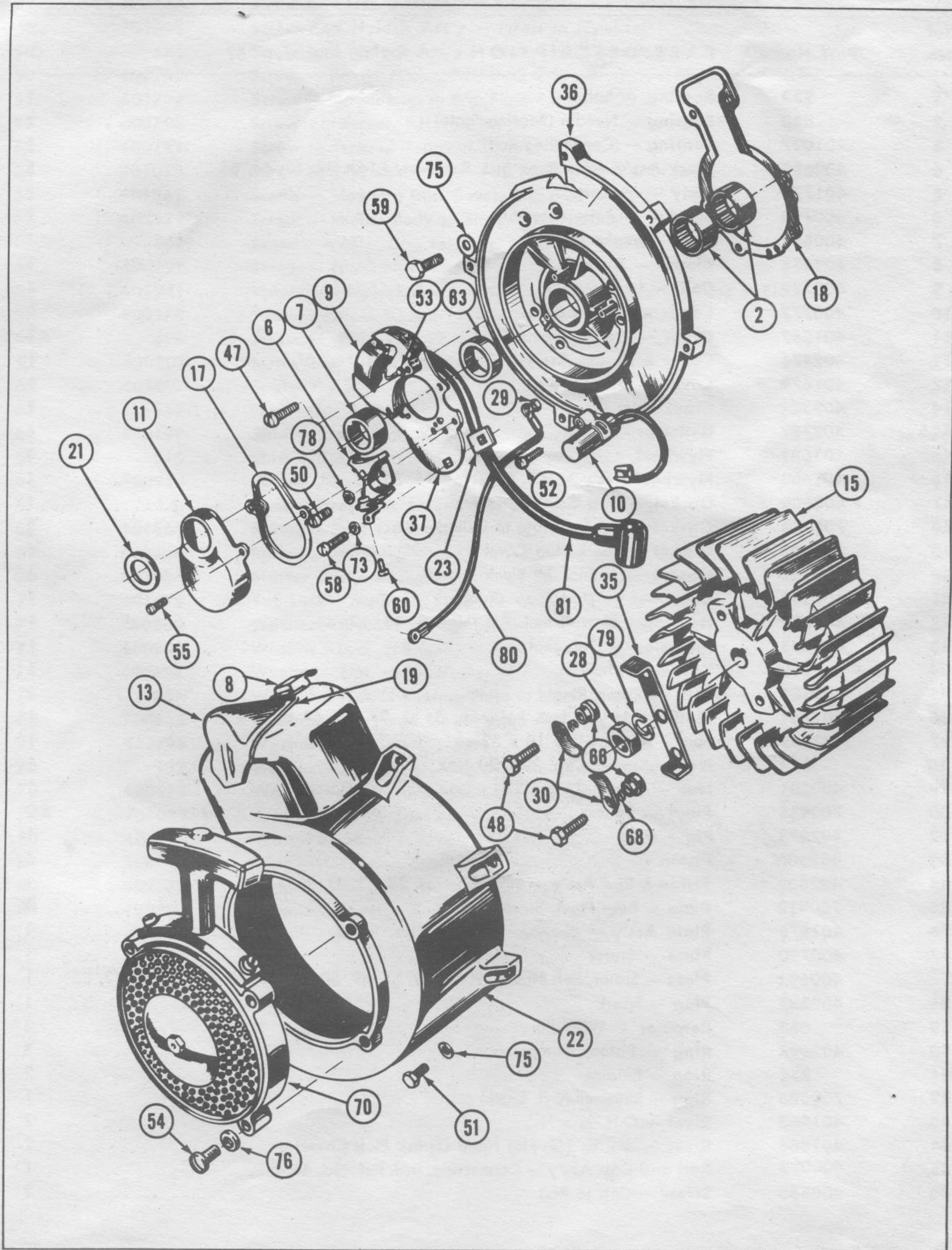

FIRST DIGIT — POWERHEADS

NOTE: The Powerhead is indicated by the first digit in the six digit Chainsaw Type Number found on the name plate.

Ref. No.	Part No.	PART DESCRIPTION	Type 57	Qty.
1	233	Bearing — Ball		1
2	820	Bearing — Needle (Bearing Plate)		2
3	401027	Bearing — (Connecting Rod)		1
4	402699	Block Ass'y — 1 $\frac{7}{8}$ Bore, Incl. Ref. Nos. 1, 41, 42, 62, 64, 65		1
5	401774	Body — Muffler		1
6	400792	Breaker — Point Assembly		1
7	400682	Cam — Breaker		1
8	402633	Clamp — Draw Pull		1
9	400789	Coil — Magneto		1
10	400777	Condenser — Magneto		1
11	401567	Cover — Breaker Point, Dust		1
12	402476	Cover & Screen Ass'y — Muffler incl. Ref. No. 67		1
13	401679	Cover — Spark Plug		1
14	402384	Crankshaft		1
14A	402727	Deflector		1
15	401681	Flywheel		1
16	401680	Flywheel Ass'y — Incl. Ref. Nos. 15, 30, 35, 48, 66, 68		1
17	400609	Gasket — Dust Cover		1
18	700743	Gasket — Bearing Plate to Cylinder Block		1
19	401987	Gasket — Spark Plug Cover		1
20	700038	Gasket — Muffler to Block		1
21	401568	Grommet — Dust Cap (Rubber)		1
22	401677	Housing — Blower, Incl. Ref. Nos. 8, 13, 19, 44		1
23	400795	Insulator — Terminal		1
24	958	Key — Flywheel		1
25	402701	Lock — Piston Ring		3
26	401761	Muffler Ass'y — Incl. Ref. Nos. 5, 12, 27, 56, 67, 71, 74		1
27	402235	Nut — Muffler, $\frac{1}{4}$ x 10 x 32		1
28	838	Nut — Starter Cup, $\frac{7}{16}$ x 20 Hex.		1
29	400801	Nut — Terminal, #6-32		1
30	700915	Pawl — Starter		2
32	402673	Pin — Wrist		1
33	402806	Piston		1
34	402808	Piston & Rod Ass'y — Incl. Ref. Nos. 25, 32, 33, 39, 40, 45		1
35	700913	Plate — Base Pawl, Starter		1
36	401675	Plate Ass'y — Bearing, Incl. Ref. Nos. 2, 63		1
37	400790	Plate — Stator		1
	400692	Plate — Stator, Ref. Nos. 6, 9, 10, 29, 37, 49, 50, 52, 53, 58, 61, 72, 73, 77, 83		1
38	402237	Plug — Spark		1
39	663	Retainer — Wrist Pin		2
40	402698	Ring — Piston, Compression		3
41	234	Ring — Retainer		2
42	700893	Ring — Retainer (Cyl. Block)		1
43	401952	Rivet — O.H. $\frac{1}{8}$ x $\frac{1}{4}$		2
44	401866	Rivet — $\frac{1}{8}$ x $\frac{3}{16}$, LG. Flat Head (Spark Plug Cover)		2
45	400093	Rod and Cap Ass'y — Connecting, Incl. Ref. No. 46		1
46	400585	Screw — Cap to Rod		2

FIRST DIGIT — POWERHEADS

Ref. No.	Part No.	PART DESCRIPTION	Type 57	Qty.
47	401566	Screw and L.W. Ass'y — P.H.S.T., #10-24 x 1 Mag. Ass'y to Brg. Plate		2
48	701028	Screw and Nylock Ass'y — Pawls to Flywheel		2
49	671	Screw and Nylock Ass'y — ¼-20-1½ Blower Hsg. to Brg. Plate		1
50	400799	Screw — Breaker Point, P.H. 8-32 x ⅝		1
51	401708	Screw — Blower Hsg. to Brg. Plate F.H.M. ¼-20 x ⅞ (Nylock)		4
52	400798	Screw Condenser, F.H., 8-32 x ⅝		1
53	400791	Screw — Ground Terminal, 4-40 x ¼		1
54	701013	Screw and Nylock Ass'y — F.H. 12-24 x ⅞—Starter to Blower Hsg.		4
55	401565	Screw — Magneto Dust Cover, S.T. 6-32 x ⅜		2
56	402529	Screw — Muffler Body to Block, S.H. ¼-20 x ¾ N.C.		2
57	363	Screw — Muffler Cap to Body, ¼-20 x 1 S.H.H.		1
58	400797	Screw — Terminal, F.H., 6-32 x ¾		1
59	401941	Screw and Nylock Ass'y — H.H.C. ¼-20 x ⅞ Bearing Plate to Block		2
60	400179	Screw — F.H. ¼-20-¾		4
60A	698	Screw — R.H.S.T. 8-32-¾		2
61	400802	Screw and Nylock Ass'y — Breaker Terminal		1
62	402407	Seal — Oil (Cyl. Block)		1
63	257-1	Seal — Oil (Bearing Plate)		1
64	400198	Shim — Crankshaft .002		as req'd
65	515	Shim — Crankshaft .005		as req'd
66	700914	Spacer — Starter		2
67	*N.S.S.	Spark Arrestor & Screen Ass'y — Muffler		1
68	401865	Spring — Starter Pawl		2
69	402309	Spring — Muffler		2
70	402454	Starter Ass'y — Recoil (See Page 26)		1
71	401479	Tab Lock — Muffler to Block		1
72	400800	Washer — Breaker Spring, Screw		1
73	400803	Washer — Lock #8		1
74	400624	Washer — Flat, #10, Muffler		1
75	657	Washer — Flat, ¼ Bearing Plate to Block, 4; Blower Hsg. to Brg. Plates, 5		9
76	700838	Washer — Starter to Blower Hsg.		4
77	400796	Washer — Insulator		1
78	192	Washer — Lock, #10, Mag. Ass'y to Blower Plate		2
79	400874	Washer — ⅞ I.D. (Crankshaft to Flywheel)		1
79A	701012	Washer — #12, Split		4
80	402719	Wire — Shorting		1
81	400794	Wire — Hi-Tension, Lead		1
82	402532	Wire — Lock		1
83	400793	Wire — Connector		1

*Not Serviced Separately

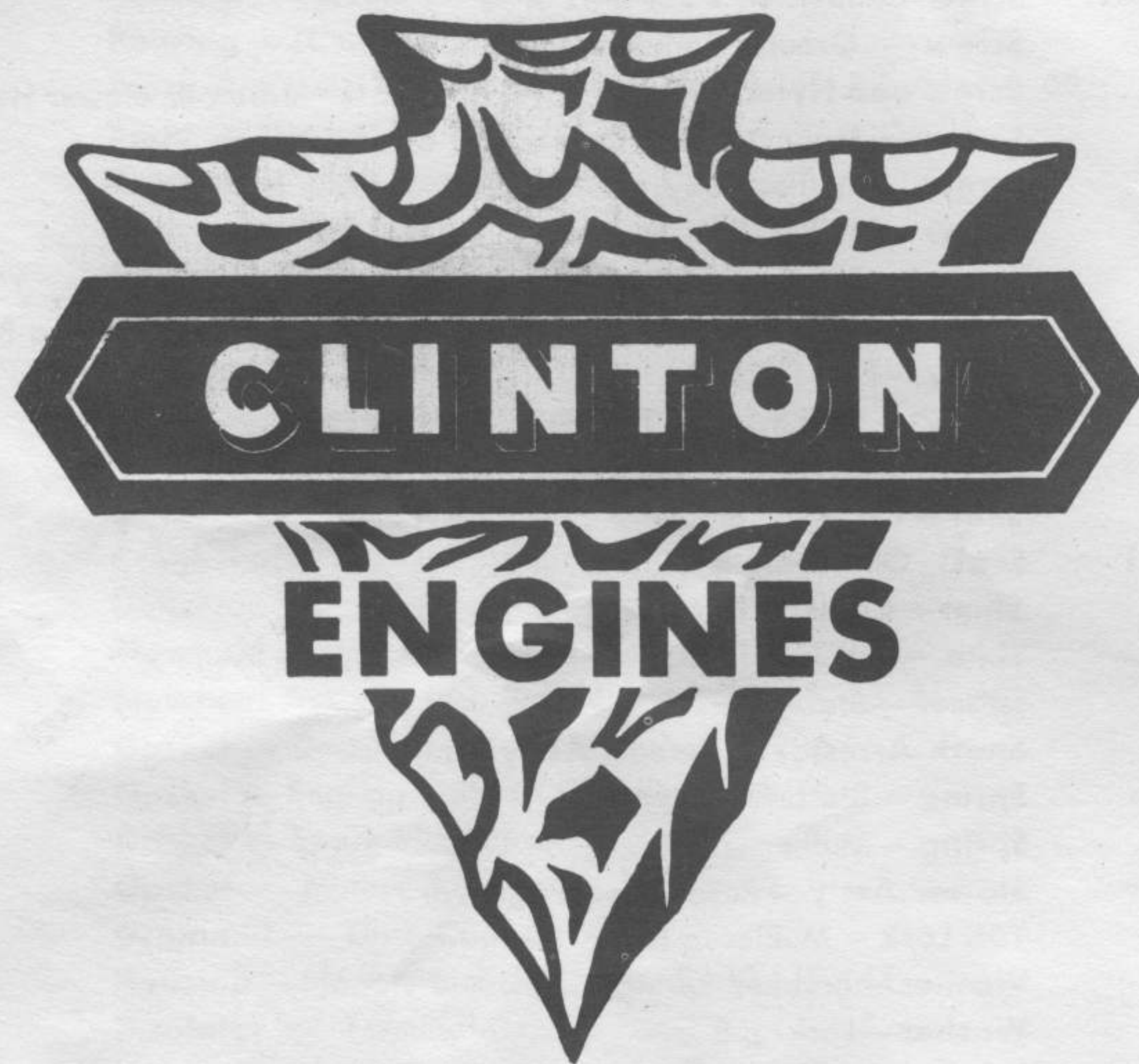

SECOND DIGIT — TANK ASSEMBLY

NOTE: The Tank Assembly is represented by the second digit in the six digit Chainsaw Type Number found on the name plate.

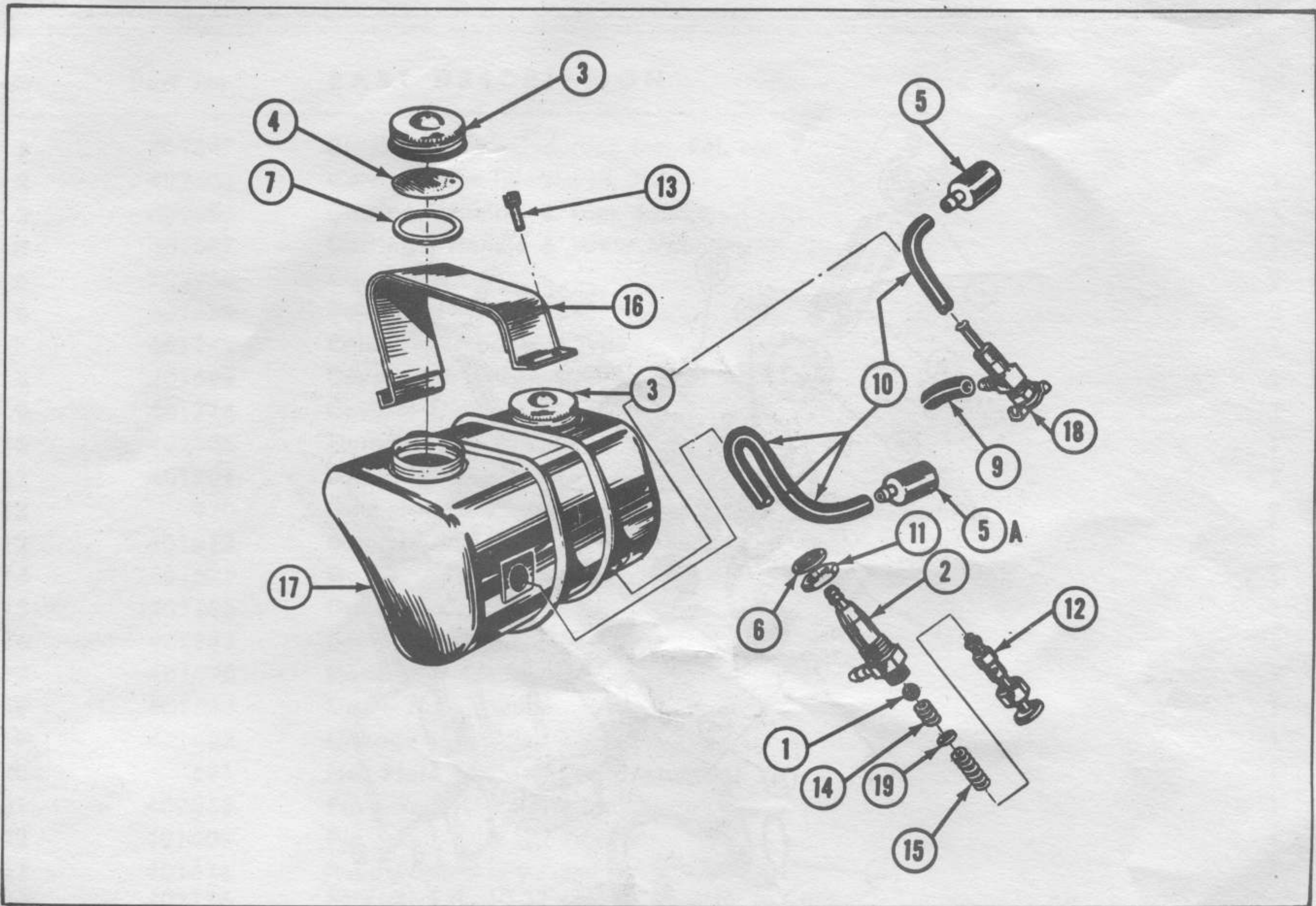

Ref. No.	Part No.	PART DESCRIPTION	Type 15	Qty.
1	400446	Ball — Oil Check		1
2	401793	Body — Oil Pump		1
3	400569	Cap Ass'y — Fuel & Oil Reservoir (Incl. Ref. Nos. 4 & 7)		2
4	400644	Diaphragm — Fuel Cap		1
5	401765	Filter — Fuel Pick-up		1
5A	402417	Filter — Oil Pick-up		1
6	400860	Gasket — Oil Pump to Tank		1
7	400645	Gasket — Fuel Cap		1
9	401544	Line — Fuel (Rubber)		1
10	401497	Line — Molded Snake		2
11	400544	Nut — Oil Pump, Adjustment		1
12	401327	Plunger — Oil Pump		1
	401792	Pump Ass'y — Oil		1
		NOTE: Ass'y Incl. Ref. Nos. 1, 2, 12, 14, 15, 19		
13	400189	Screw & L'washer Ass'y — F.H. #10-24 x 5/8" (Nylock)		4
14	400447	Spring — Check Ball		1
15	400453	Spring — Oil Pump, Plunger		1
16	401700	Strap — Tank Retaining		1
17	402107	Tank Ass'y — Fuel & Oil		1
18	401878	Valve — Fuel Shut-off		1
19	401332	Washer — Spring		1

Note: Specify Chainsaw Model, Type Number and Serial Number when ordering Repair Parts.

THIRD DIGIT — INDUCTION ASSEMBLY

Note: The Induction Assembly is indicated by the third digit in the six digit Chainsaw Type Number found on the name plate.

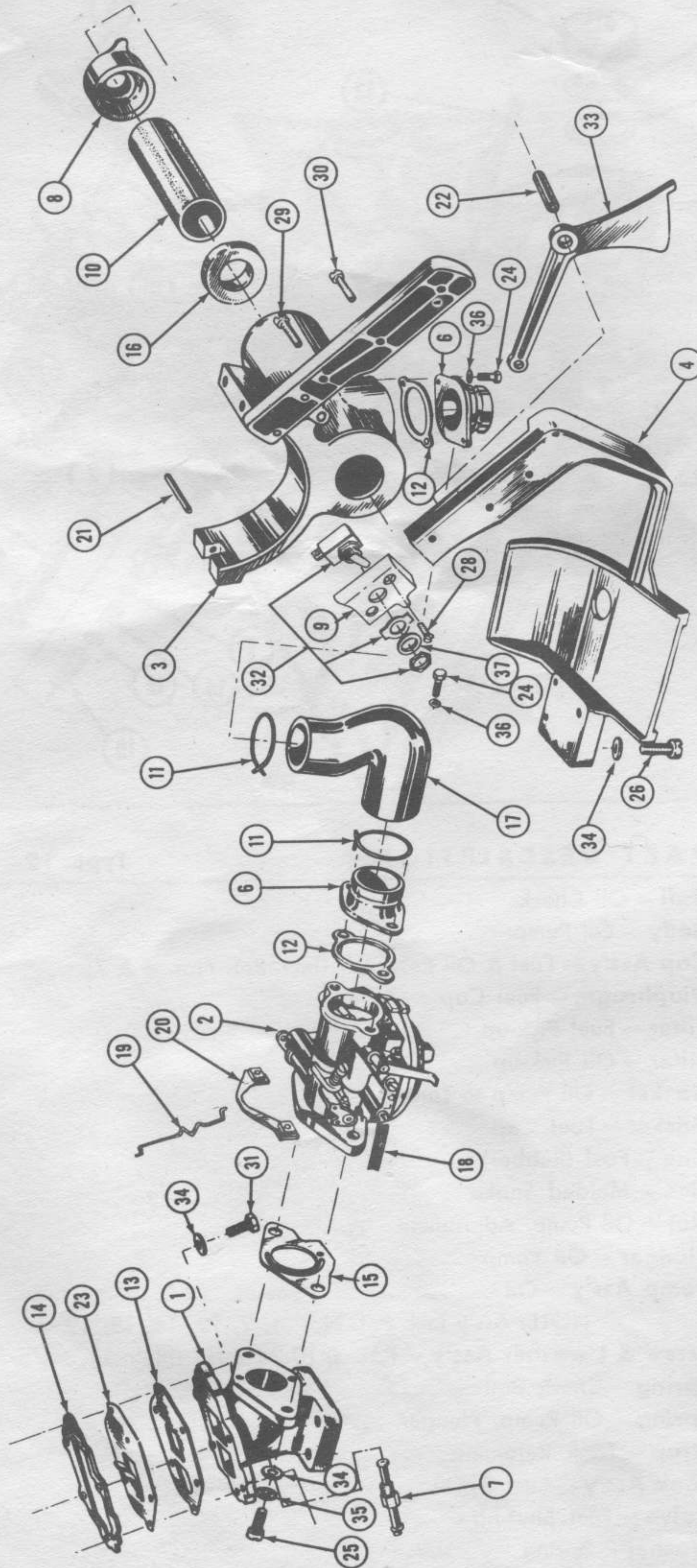

THIRD DIGIT — INDUCTION ASSEMBLY

NOTE: The Induction Assembly is indicated by the third digit in the six digit Chainsaw Type Number found on the name plate.

Ref. No.	Part No.	PART DESCRIPTION	Type 50	Qty.
1	401847	Bracket Ass'y — Induction Incl. Ref. No. 7		1
2	402203	Carburetor — Tillotson HL 20AX		1
3	401686	Casting — Handle & Tank Saddle		1
4	401687	Casting — Handle & Lower Mounting		1
5	700950	Clip — Fuel Line		2
6	401689	Connector — Air Cleaner Hose		2
7	401248	Connector — Bayonet Type		1
8	401699	Cover — Air Cleaner		1
9	401714	Cover — Shorting, Switch		1
10	402306	Element — Air Cleaner		1
11	401701	Fastener — Hose		2
12	920	Gasket — Air Cleaner Mounting Plate		2
13	401612	Gasket — Induction Bracket to Reed Plate		1
14	401629	Gasket — Reed Plate to Block		1
15	401688	Gasket — Carburetor		1
16	401382	Grommet — Rubber		1
17	401690	Hose — Air Cleaner		1
18	401528	Line — Hose Impulse		1
19	401692	Linkage — Throttle		1
20	681	Nut Plate Ass'y — (Carb. Mounting)		1
21	400863	Pin — Roll, 1/8" x 1 1/2", Tank Strap		1
22	401409	Pin — Roll, 3/8" x 7/8", Trigger		1
23	401616	Reed Plate Ass'y — Induction		1
24	402126	Screw — F.H., 10-32 x 1/2", (Connector to Carb.—2; Connector to Air Cleaner—2)		4
25	400648	Screw — F.H.M., 1/4"-20 x 1", Carburetor to Induction Bracket		2
26	656	Screw — F.H.M., 1/4"-20 x 1" (Nylock), Induction Bracket to Handle		4
27	400612	Screw — F.H.M., 3/8"-18 x 7/8" (Nylock), Handle & Tank Saddle to Main Casting		2
28	401732	Screw — S.T.O.H., #8-32 x 3/4", Switch Cover to Handle Casting		2
29	401704	Screw & Nylock Ass'y — F.H., #12-24 x 7/8", Handle & Tank Saddle to Handle & Lower Mounting Casting		2
30	401733	Screw & Nylock Ass'y — F.H., #12-24 x 3/4", Handle & Tank Saddle to Handle & Lower Mounting Casting		1
31	700898	Screw & Nylock Ass'y — S.H.H., 1/4"-20 x 7/8", Induction Bracket to Block		6
32	860	Switch Ass'y — Shorting, Incl. Lock Nut		1
32A	402307	Spring — Air Hose		1
33	401691	Trigger — Throttle		1
34	657	Washer — Flat, 1/4"		12
35	114	Washer — Lock, 1/4"		2
36	192	Washer — Lock, #10		4
37	400323	Washer — Lock (Special), Shorting Switch		1

NOTE: Specify Chainsaw Model, Type & Serial Number when ordering Repair Parts.

FIFTH DIGIT — TRANSMISSION ASSEMBLY

NOTE: The Transmission Assembly is represented by the fifth digit in the six digit Chainsaw Type Number found on the name plate.

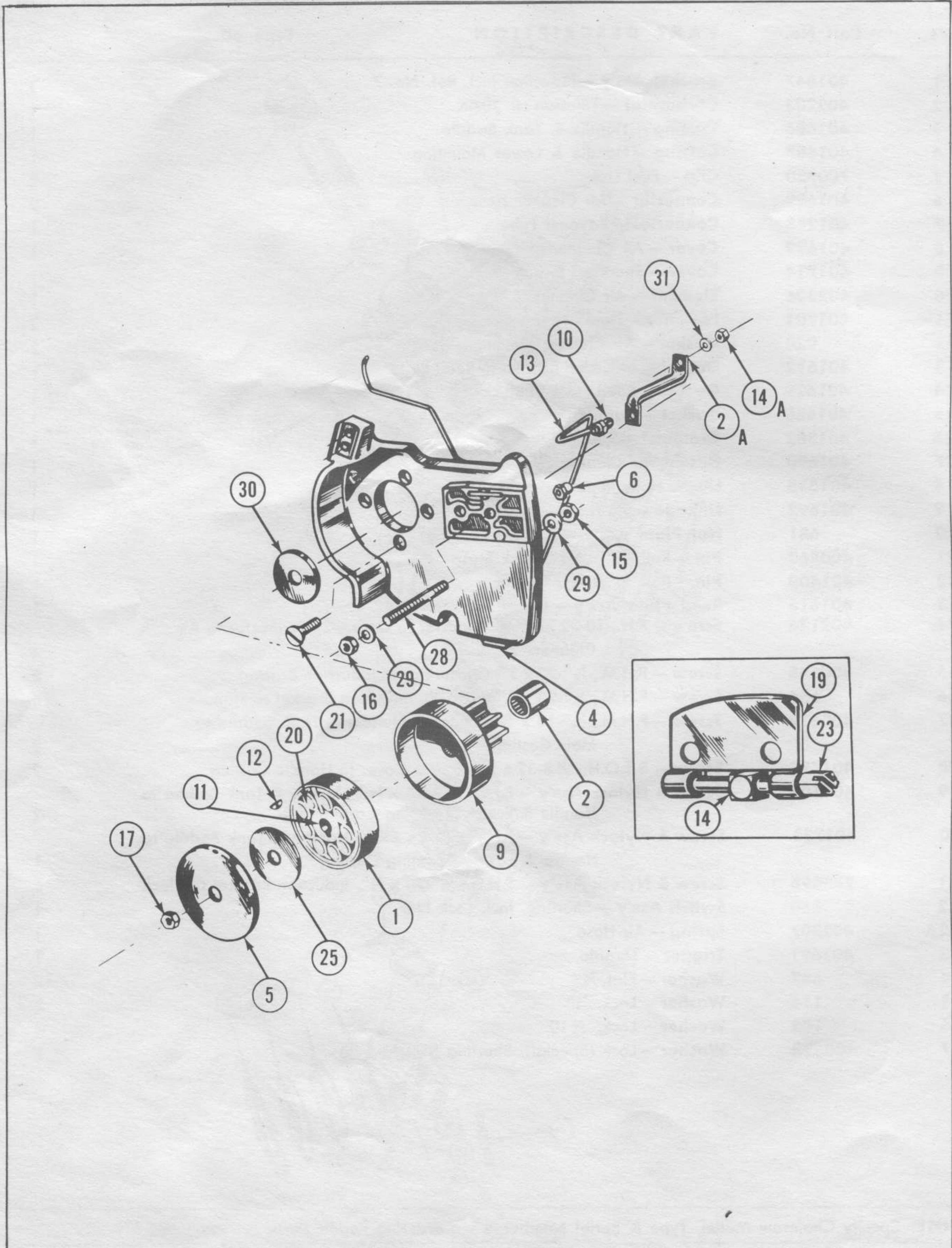

FIFTH DIGIT — TRANSMISSION ASSEMBLY

NOTE: The Transmission Assembly is represented by the fifth digit in the six digit Chainsaw Type Number found on the name plate.

Ref. No.	Part No.	PART DESCRIPTION	Type 40	Qty.
1	402639	Band Ass'y — Clutch, Incl. Friction and Steel Band		1
2	402408	Bearing — Needle		1
2A	402424	Brace — Strut		1
4	402423	Casting		1
5	402389	Cover — Clutch		1
7	402645	Clutch Ass'y — Incl. Ref. Nos. 1, 11, 20		1
9	402450	Cup and Sprocket Ass'y		1
11	401830	Hub — Clutch		1
12	184	Key — Woodruff, #6, $\frac{5}{32}$ " x $\frac{5}{8}$ "		1
13	401695	Line Ass'y — Oil		1
14	400985	Lug — Chain Tension		1
14A	132	Nut — Hex 44-20, Strut Brace to big Plate		1
15	402550	Nut — $\frac{3}{8}$ - $\frac{3}{4}$ —Opposite End of Stud		1
16	402521	Nut — Guide Bar Studs		2
17	400846	Nut — $\frac{7}{16}$ -20 L.H. Grip		1
19	400986	Plate Ass'y — Tension, Incl. Ref. Nos. 14, 23		1
20	401803	Roller		8
21	401697	Screw and Nylock Ass'y — F.H.M., $\frac{5}{16}$ "-18 x $\frac{7}{8}$ " (Main Casting to Block—4; Main Casting to Air Cleaner)		6
23	400987	Screw — Chain Tension		1
25	400540	Spacer — Clutch, Cover		1
25A	401800	Spring — Clutch		1
28	402535	Studs — Guide Bar		2
29	507	Washer — Flat, $\frac{13}{32}$ " x $\frac{13}{16}$ " x $\frac{1}{16}$ "		3
30	402388	Washer — Guide Bar		1
31	480	Washer — Lock— $\frac{1}{4}$, Strut brace to Bearing Plate		1

SIXTH DIGIT — TUBULAR HANDLE ASSEMBLY

NOTE: The Tubular Handle Assembly is indicated by the sixth digit in the six digit Chainsaw Type Number found on the name plate.

This handle, which offers the full-wrap-around features, can be purchased from your authorized Clinton dealer and installed on your unit.

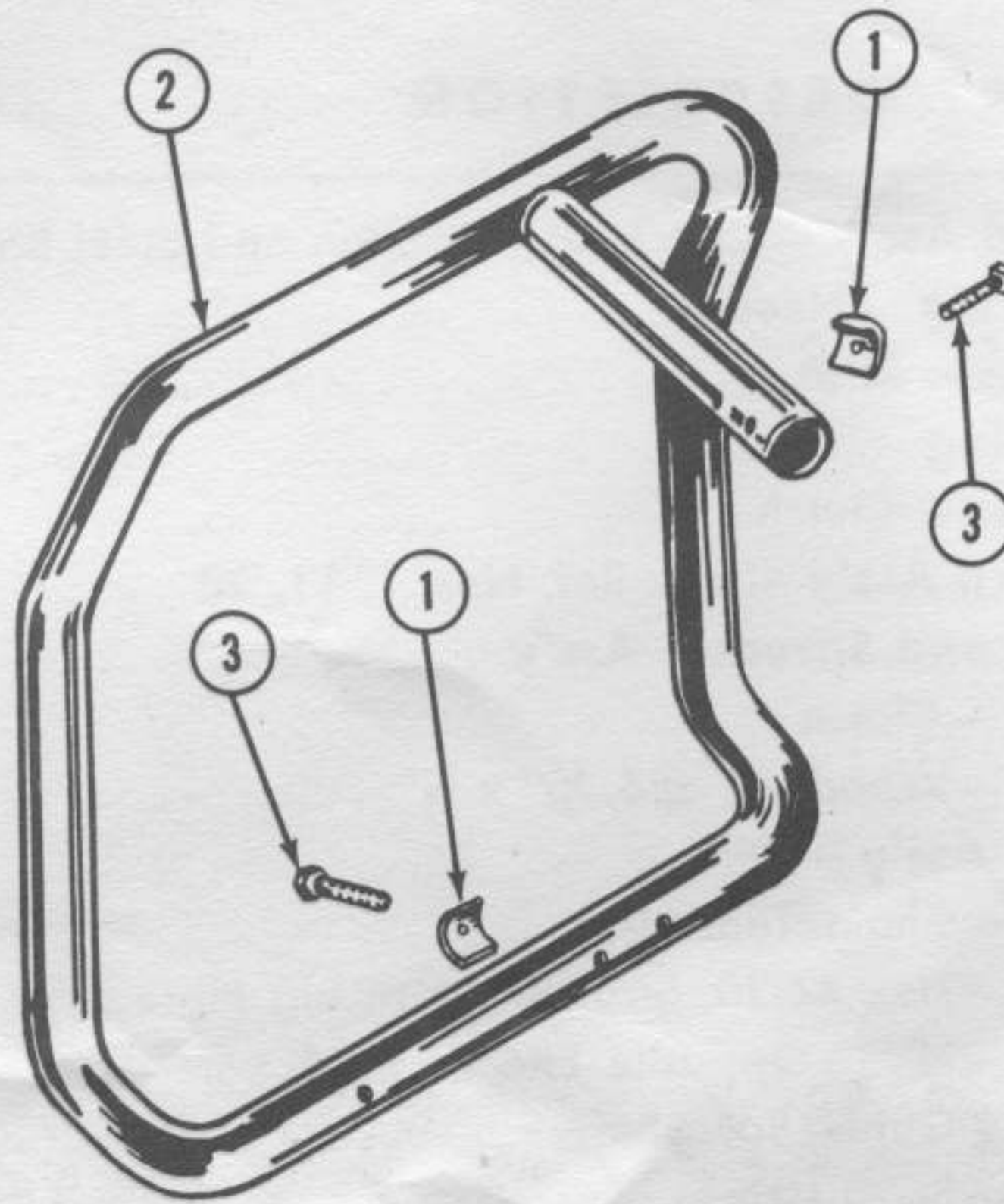

Ref. No.	Part No.	PART DESCRIPTION	TYPE 20	Qty.
1	201	Clamp — Tubular Handle	5
2	402505	Handle — Tubular	1
3	401815	Screw & L'washer Ass'y — H.H.C ¼-20 x 1½	5

STANDARD PART OF UNIT

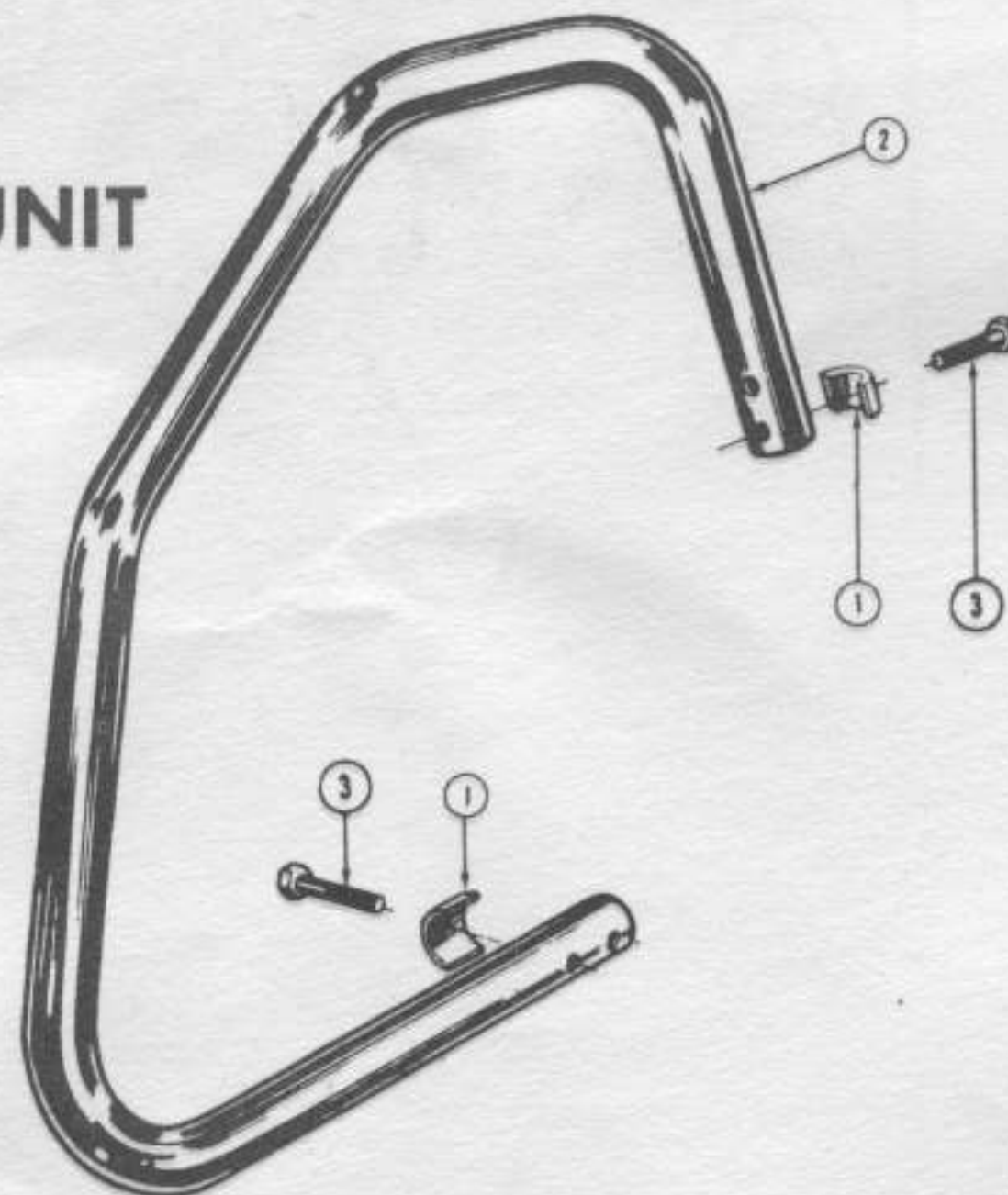

TYPE 21				
1	201	Clamp — Tubular Handle	5
2	402537	Handle — Tubular	1
3	401815	Screw & Nylock Ass'y — H.H.C. ¼-20 x 1½	5

**ALWAYS USE
GENUINE CLINTON
PARTS**

CARBURETOR

PART NUMBER: C402203
REPAIR PARTS C401185
KIT.

Ref. #	Part No.	PART DESCRIPTION	Qty.
1	C401135	Body — Fuel Pump	1
2	C761	Bushing — Throttle Shaft	2
3	C739	Clip — Throttle Shaft	1
4	C401158	Cover — Carburetor, Diaphragm	1
5	C401151	Cover — Fuel Pump, Strainer	1
6	*C401146	Diaphragm — Carburetor	1
7	*C401148	Diaphragm — Fuel Pump	1
9	C401176	Gasket — Fuel Pump	1
10	C401137	Gasket — Fuel Pump Diaphragm Cover	1
11	C401134	Gasket — Fuel Strainer, Cover	1
12	C401201	Gasket — Inlet Seat	1
13	*C401186	Gasket & Packing Set	1
14	*C401142	Inlet Needle Seat & Gasket	1
15	C401185	Kit — Repair Parts	1
16	*C401144	Lever — Inlet Control	1
17	C401200	Lever — Throttle	1
18	C402717	Lever — Throttle Shaft & Stop	1
20	C722	Pin — Choke Friction	1
21	*C401184	Plug — Body Channel, Cup	1
22	*C401183	Plug — Body Channel, Welch	1
23	*C401149	Screen — Fuel Inlet	1
24	C733	Screw — Choke Shutter	1
25	C715	Screw — Diaphragm Chamber, Drain	1
26	*C401150	Screw — Fuel Pump, Cover	1
27	C401138	Screw — Idle Adjustment	1
28	*C401203	Screw — Idle Speed Regulating	1
29	*C401199	Screw — Inlet Control Lever Pinion Screw	1
30	*C401143	Screw — Main Adjustment	1
31	*C401189	Screw — Throttle Lever Retaining	1
32	C401192	Screw — Throttle Shaft Retaining	1
33	*C733	Screw — Throttle Shutter	1
34	C401175	Screw & Lockwasher Ass'y — Fuel Pump Body	6
35	C401204	Seal — Main Adjustment Screw—1; Idle Adjustment—1	2
37	C402716	Shaft & Lever Ass'y — Choke	1
38	C401141	Shutter — Choke	1
39	C728	Shutter — Throttle	1
40	C401179	Spring — Choke Friction	1
41	*C710	Spring — Idle Speed Screw	1
42	C401198	Spring — Inlet Tension	1
43	*C401191	Spring — Throttle Shaft Return	1
44	*C401188	Washer — Throttle Lever Retaining, Lock	1
45	C711	Washer — Throttle Shaft Clip Lock	1

NOTE: Parts with (*) Comprise Repair Parts Kit

RECOIL STARTER

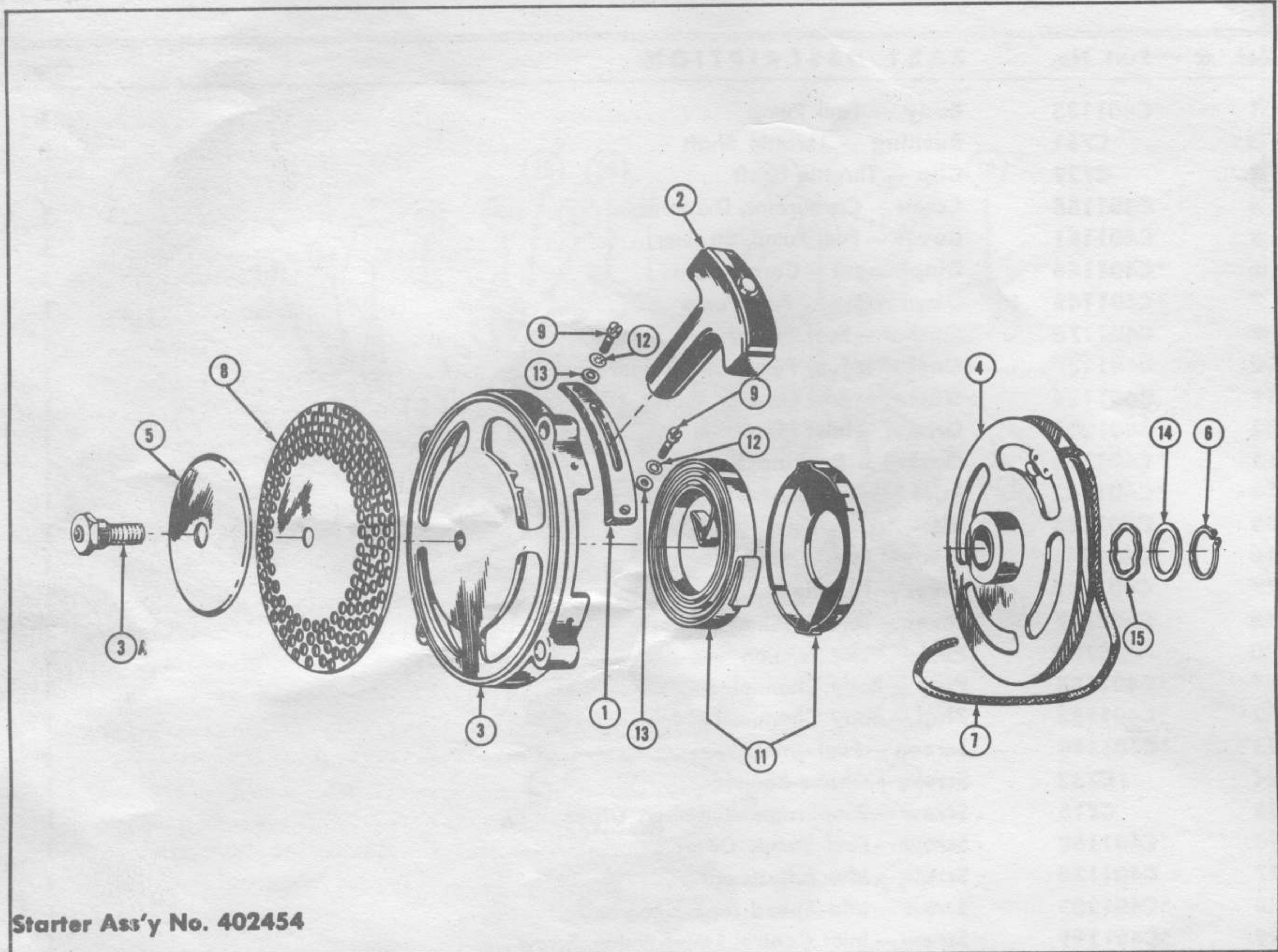

Starter Ass'y No. 402454

Ref. No.	Part No.	PART DESCRIPTION	Qty.
1	401834	Guide — Rope	1
2	700949	Handle — Starter	1
3	402459	Housing	1
3A	402493	Plug — Grease	1
4	401869	Pulley	1
5	402457	Retainer — Screen	1
6	401947	Ring — Retaining	1
7	700943	Rope	1
8	402458	Screen	1
9	701016	Screw — #10-24 x 1/2" (Pull Guide to Starter Hsg.)	2
11	401835	Spring & Cup Ass'y	1
12	192	Washer — #10, Lock	2
13	400624	Washer — #10, Plain	2
14	401946	Washer — Steel, Retaining	1
15	401945	Washer — Wave	1

NOTE: Specify Chainsaw Model, Type Number and Serial Number when ordering Repair Parts.

GUIDE BARS & CHAINS

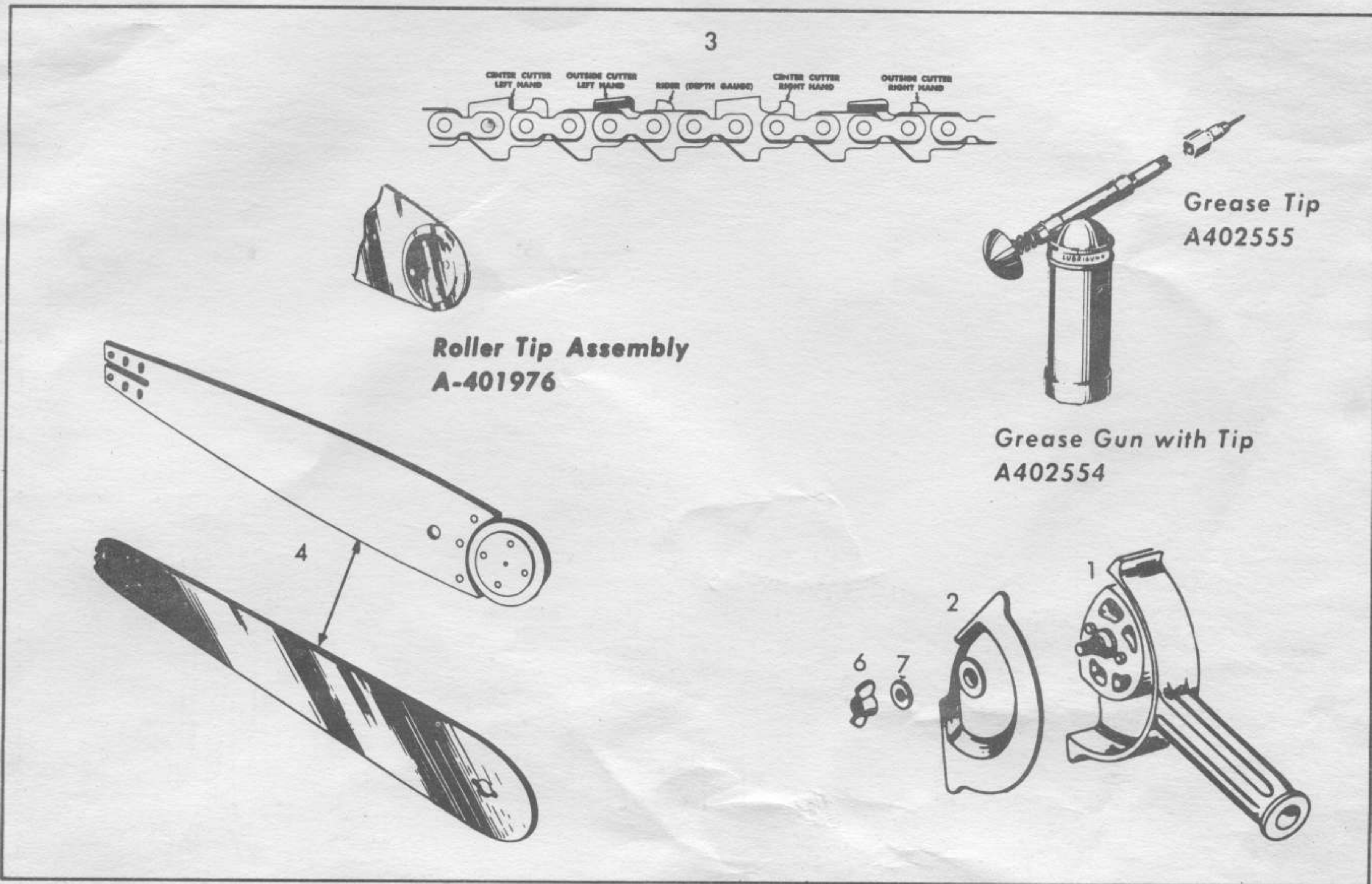

Ref. No.	Part No.	PART DESCRIPTION	Qty.
1	A564	Body Ass'y	1
2	A565	Cover - Helper's Handle	1
3	H402480	Chain - 16" (Roller Tip Bar)	1
	H402642	Chain - 16" (Stellite Tip Bar)	1
	H402481	Chain - 20" (Roller Tip Bar)	1
	H402643	Chain - 20" (Stellite Tip Bar)	1
	H402482	Chain - 26" (Roller Tip Bar)	1
	H402644	Chain - 26" (Stellite Tip Bar)	1
4	A402221	Guide Bar - 16" (Roller Tip)	1
	A400855	Guide Bar - 16" (Stellite Tip)	1
	A401990	Guide Bar - 20" (Roller Tip)	1
	A400854	Guide Bar - 20" (Stellite Tip)	1
	A401991	Guide Bar - 26" (Roller Tip)	1
	A400870	Guide Bar - 26" (Stellite Tip)	1
	A563	Helper's Handle Ass'y - Incl. Ref. Nos. 1, 2, 6, 7	1
5*	H402559	Kit - Master Link Repair	1
6	A567	Nut - Wing	1
7	A569	Washer - 1/2 S.A.E. Helper's Handle	1

* H402559 REPAIR KIT

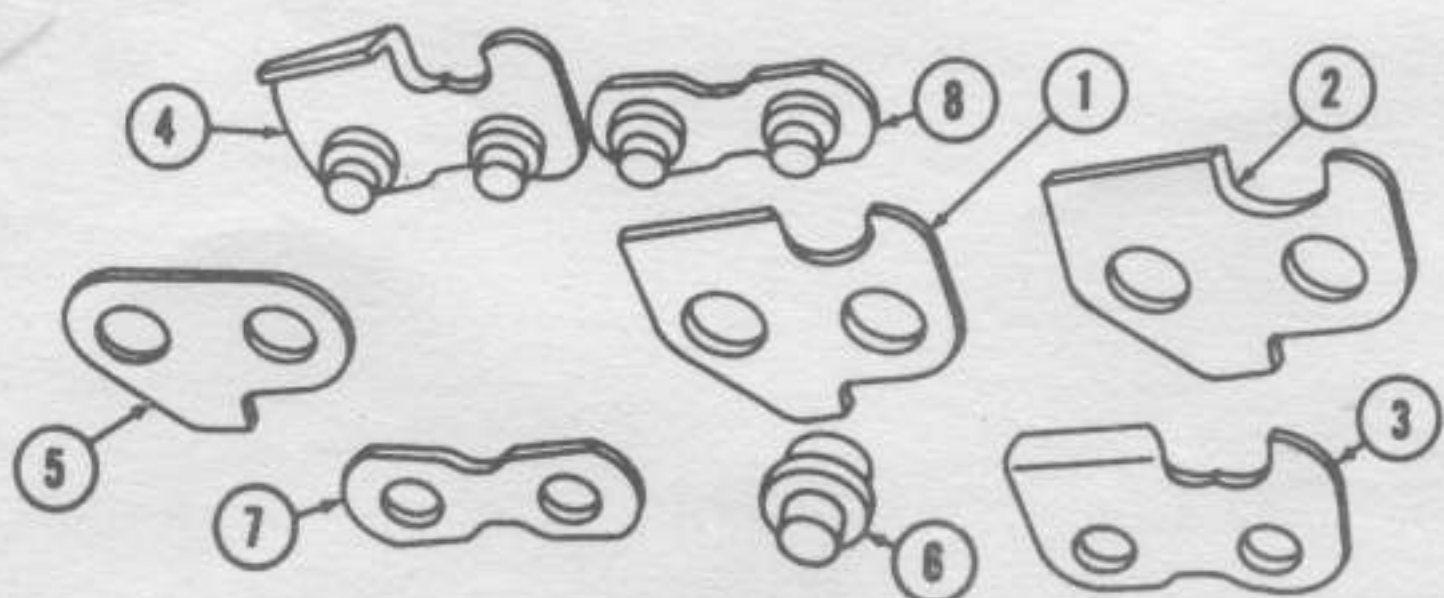

1	H402370	Cutter - Center, R.H.	1
2	H402371	Cutter - Center, L.H.	1
3	H401031	Cutter - Outside, R.H.	1
4	H401030	Cutter - Outside, L.H.	1
5	H400747	Drive Link	1
6	H400912	Rivet	8
7	H400748	Tie Strap - Plain	1
8	H401160	Tie Strap - Pre-Set	1

