

Workshop Manual  
GZ4350

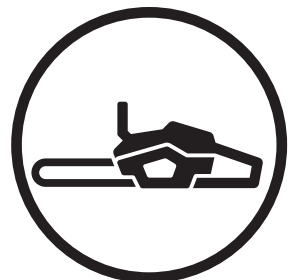

English



---

# Workshop Manual

## GZ4350

### Contents

Index .....	3
Introduction and safety instructions .....	6
Technical data.....	9
Service tools .....	11
Service data.....	13
Safety equipment .....	15
Repair instructions.....	23
Troubleshooting .....	57

Husqvarna AB has a policy of continuous product development and therefore reserves the right to modify the design and appearance of products without prior notice.

# Index

## C

- Carburettor 34
  - Adjustment 42
  - Assembly 38
  - Cleaning and inspection 38
  - Design 34
  - Dismantling 36
  - Function 35
  - Pressure testing 40
- Centrifugal clutch 30
  - Assembly of centrifugal clutch 31
  - Cleaning and inspection 30
  - Dismantling the centrifugal clutch 30
- Chain brake 17
  - Assembling the chain brake 18
  - Cleaning and inspection 17
  - Dismantling the chain brake 17
  - Functional inspection 19
- Chain catcher 20
  - Replacing the chain catcher 20
- Crankshaft and crankcase 53
  - Assembling a complete crankshaft 54
  - Bearings and oil seals 55
  - Cleaning and inspection 54
  - Dismantling the crankcase and crankshaft 53
- Cylinder cover 22
  - Removing cylinder cover 22
  - Replacing cylinder cover 22

## F

- Fuel system 46
  - Replacing the fuel filter 46
  - Replacing the fuel hose 46
  - Replcing the primer bulb 46

## H

- Handle heating system 47

## I

- Ignition module and flywheel 28
  - Assembling the ignition module and flywheel 29
  - Cleaning and inspection 28
  - Dismantling the ignition module and flywheel 28
- Intake system 32
  - Assembling the intake system 33
  - Cleaning and inspection 32
  - Dismantling the intake system 32
- Introduction and safety instructions 7
  - General 7
  - General Instructions 8
  - Modifications 7
  - Safety 7
  - Special Instructions 8
  - Structure 7
  - Target group 7
  - Tools 7

## M

- Muffler 19
  - Assembling the muffler 20
  - Cleaning and inspection 19
  - Dismantling the muffler 19

## O

- Oil pump and screen 31
  - Assembling the oil pump and screen 32
  - Cleaning and inspection 31
  - Dismantling the oil pump and screen 31

## P

- Piston and cylinder 49
  - Assembling the piston and cylinder 51
  - Dismantling the piston and cylinder 49
  - Faults and causes 50
  - Leakage testing the the cylinder 50

## S

- Service data 14
- Service tools 12
- Starter 25
  - Cleaning and inspection 25
  - Dismantling the starter 25
  - Replacing a broken or worn starter cord 26
  - Tensioning the return spring 26
  - Replacing a broken return spring 27
  - Starter assembly 27
- Stop switch 20
  - Dismantling the stop switch 20
  - Resistance test - stop switch 21
- Symbols
  - Symbols in the Workshop Manual 9
  - Symbols on the chain saw 9

## T

- Tank unit 44
  - Assembly 44
  - Dismantling 44
- Technical Data 10
- Throttle trigger lockout, throttle trigger and spring 22
  - Assembling the throttle trigger lockout, throttle trigger and spring 23
  - Cleaning and inspection 22
  - Dismantling the throttle trigger lockout, throttle trigger and spring 22
- Troubleshooting 58
- Troubleshooting methods 59

## V

- Vibration damping system 45
  - Assembly 45
  - Cleaning and inspection 45
  - Dismantling 45



## 2 Introduction and safety regulations

### Contents

2.1	General .....	6
2.2	Safety .....	6
2.3	Target group .....	6
2.4	Modifications .....	6
2.5	Tools .....	6
2.6	Structure .....	6
2.7	Numbering .....	6
2.8	General instructions .....	7
2.9	Special instructions .....	7
2.10	Symbols on the saw .....	8
2.11	Symbols in the Workshop Manual .....	8

## 2 Introduction and safety instructions

### 2.1 General

This Workshop Manual describes in detail how to be troubleshoot, repair and test the chain saw. A description of different safety steps that must be taken during repair work is also given.

### 2.2 Safety

Note: The section dealing with safety must be read and understood by all those carrying out repair work or service on the chain saw.

Warning symbols can be found in this Workshop Manual and on the chain saw. See "Symbols on the saw" and "Symbols in the Workshop Manual". A new warning symbol decal must be applied as soon as possible if a warning symbol on the chain saw has been damaged or is missing so that the greatest level of safety can be maintained when using the chain saw.

### 2.3 Target group

This Workshop Manual is written for personnel who are assumed to have general knowledge of repairing and servicing chain saws.

The Workshop Manual must be read and understood by personnel who will carry out repair work and service on the chain saw. The Manual is also suitable for use when training new employees.

### 2.4 Modifications

Any modifications to the chain saw will be gradually introduced into ongoing production. As these modifications affect service and/or spare parts, specific service information will be sent out on each occasion. This means that in time this Workshop Manual will become out of date. In order to prevent this, the Manual should be read together with all service information concerning the chain saw in question.

### 2.5 Tools

Special tools are required for some stages. All service tools are listed in the Workshop Manual. Usage is made apparent in each section.

Always use Husqvarna's original:

- Spare parts
- Service tools
- Accessories

### 2.6 Structure

This Workshop Manual can be used in two different ways:

- Repair of a specific system on the chain saw.
- Dismantling and assembly of the entire chain saw.

#### Repair of a specific system

When a particular system on the chain saw is to be repaired, proceed as follows:

1. Look up the page for the system in question.
2. Carry out the following steps:
  - Dismantling
  - Cleaning and inspection
  - Assembly

#### Dismantling and assembling the chain saw.

Proceed as follows when the chain saw is to be dismantled and assembled:

1. Open the "Repair instructions" chapter which deals with the Starter and carry out the instructions outlined under the Dismantling heading.
2. Work forward in the Manual and carry out Dismantling in the order set out in the sections.
3. Go back to the Starter and carry out the instructions under Cleaning and Inspection.
4. Work forward in the Manual and carry out Cleaning and Inspection in the order set out in the sections.
5. Order or collect all requisite spare parts from the stores.
6. Look up the "Repair instructions" chapter which deals with the Crankcase and carry out the instructions outlined in Assembling.
7. Work back in the Manual and carry out Assembling in the order set out in the sections.

Some sections include an introductory Description of the actual unit in order to increase the basic understanding.

### 2.7 Numbering

Position references to components inside the figures are designated A, B, etc.

The figures are numbered 1, 2 etc.

The position references and figure numbers restart in each new section.

## 2.8 General Instructions

The workshop where the chain saw is to be repaired must be equipped with safety equipment in accordance with local regulations.

No one may repair the chain saw unless they have read and understood the content of this Workshop Manual.

This workshop manual contains the following warning boxes in relevant places.

	<p><b>WARNING!</b> The warning box warns of the risk of personal injury if the instructions are not followed.</p>
---	---

<p><b>NOTE!</b> This box warns of material damage if the instructions are not followed.</p>
---

## 2.9 Special Instructions

The fuel used in the chain saw has the following hazardous properties:

- The fluid and its vapour are poisonous.
- Can cause eye and skin irritation.
- Can cause breathing problems.
- Is highly inflammable.

When using compressed air, do not direct the jet towards your body. Air can penetrate into the blood stream, which can endanger life.

Wear protective earplugs or earmuffs when test running.

After test running, do not touch the muffler until it has cooled down. Risk of burns. Use protective gloves when working with the muffler.

Do not start the chain saw unless the guide bar, saw chain and clutch cover (chain brake) are fitted, otherwise the clutch may loosen and cause personal injury.

Insufficient saw chain lubrication can result in saw chain breakage, which can cause serious or even life-threatening injury.

Exercise care to ensure the starter spring does not fly out and cause personal injury. Wear protective glasses. If the spring tension is activated on the starter pulley when it is to be taken up, the spring can fly out and cause personal injury.

Check that the brake is applied when removing the pressure spring on the chain brake. Otherwise the pressure spring can fly out and cause personal injury.

After repairing, check the chain brake, see "Assembling chain brake \ Function check".

Keep in mind the fire risk. The chain saw may emit sparks, which cause ignition.

Check the chain catcher and replace it if it is damaged.



## 2.10 Symbols on the chain saw

The symbols below are embedded on the chain saw.

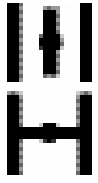

Choke Lever

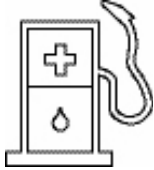

Refuelling



Stop switch



Chain oil fill

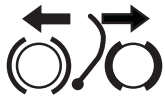

Chain brake

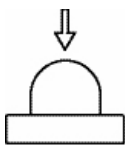

Primer bulb



Adjusting the oil pump



Heated handles

## 2.11 Symbols in the Workshop Manual



This symbol warns of personal injury when the instructions are not followed.



Wear protective gloves.



Wear protective goggle.

### 3 Technical data



Displacement  
cm<sup>3</sup>/cubic inch

GZ4350

43,1 / 2.63

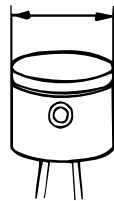

Cylinder diameter  
Ø mm/Ø inch

42 / 1.65

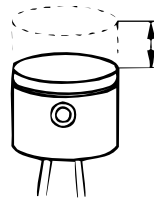

Stroke length  
mm/inch

31,1 / 1.22

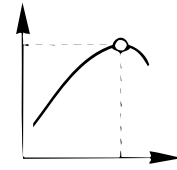

Max. output/speed  
kW/hp/rpm

2,2 / 2.95 / 9 600

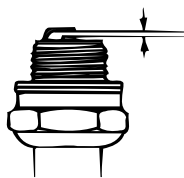

Electrode gap  
mm/inch

GZ4350

0,65 / 0.025

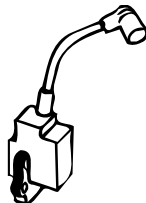

Ignition system

IKEDA UK-09701



Air gap  
mm/inch

0,4 / 0.016



Carburettor type

Walbro HD-54B

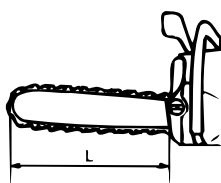

Usable cutting length  
cm/inch

GZ4350

31-43 / 12-17



Chain speed at 133% of  
maximum engine power speed  
ft/s / m/s

80.7 / 24,6

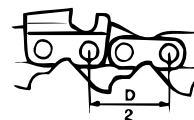

Chain pitch  
mm/inch

8,25 / 0.325

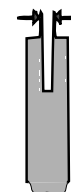

Drive link  
mm/inch

1,3 / 0.050 - 1,5 / 0.058

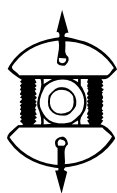

Engage speed  
rpm

GZ4350

4100 (+/- 250)



Spark plug

NGK CMR7H

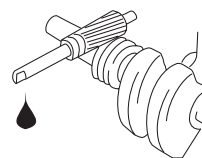

Type of oil pump

Adjustable



Volume fuel tank  
Litre/US. pint

GZ4350

0,42 / 0.87

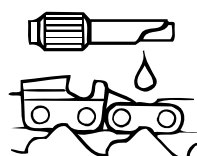

Capacity oil pump at  
9,000 rpm,  
ml/min

3-13



Volume oil tank  
Litre/US. pint

0,27 / 0.57



Weight without bar and chain  
kg / lbs

GZ4350

4,5 / 9.92



Heated handles

-

# 4 Service tools

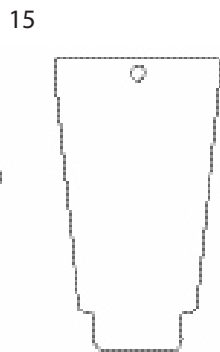
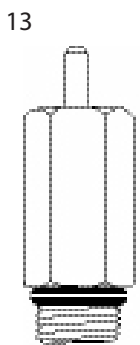
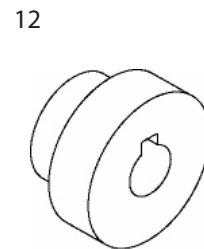
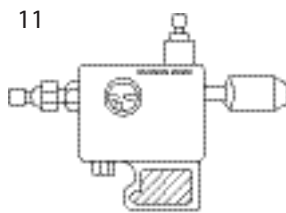
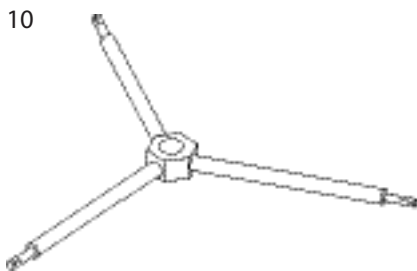
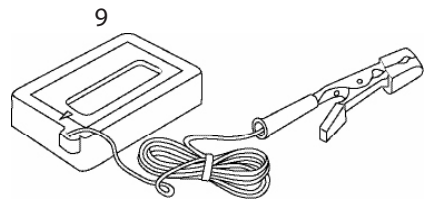
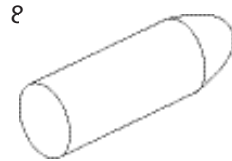
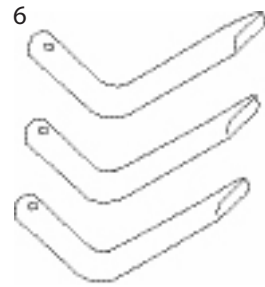
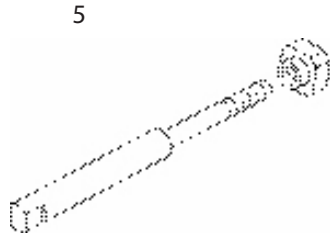
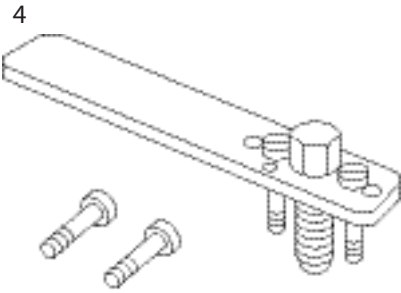
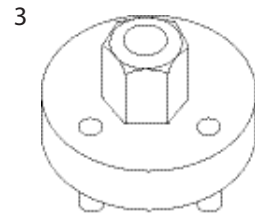

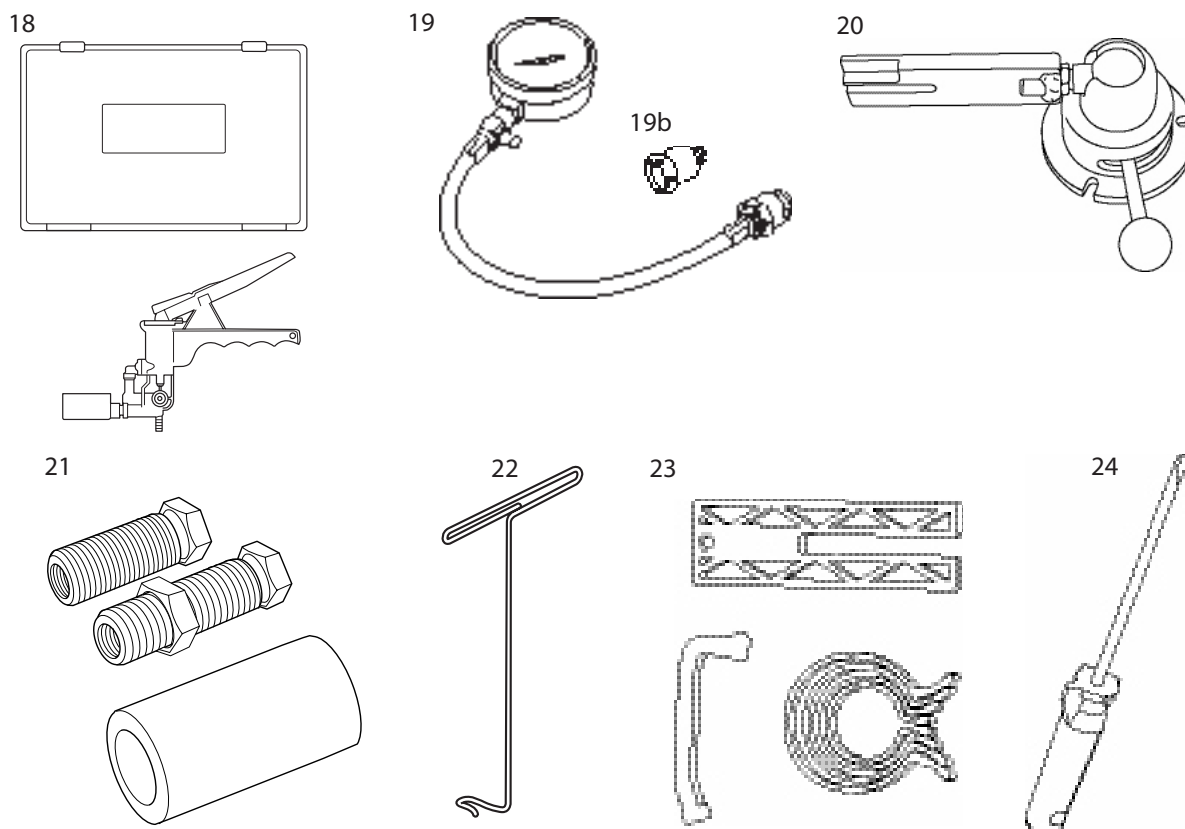

The tools listed here are the service tools required for this model of chain saw. In addition to these tools, a normal kit of hand tools is required.

Pos.	Description	Used for	Order No.
1	Air gap tool, ignition	Setting ignition module	514 24 41-01
2	Piston stopper	Locking the crank shaft	581 40 85-01
3	Wrench	Clutch out or in	513 63 60-01
4	Puller assy	Rotor out	510 13 89-01
5	Rod assy	Piston pin out or in	521 53 35-01
6	Wrench	Clutch spring in	513 63 65-01
7	Guide	Brake spring out or in	513 63 70-01
8	Guide	Crankshaft in	513 70 59-01
9	Tachometer	Engine speed meter	502 71 14-01
10	Torx wrench	T20/T25/T27	578 28 90-01
11	Ignition checker	Spark strength check	501 97 64-01
12	Guide	Setting heating coil (543XPG)	512 41 31-01
13	Spark plug adapter	Pressure testing	503 84 40-03
14	Cover plate, inlet	Pressure testing	574 71 14-01
15	Rubber wedge, outlet	Pressure testing	502 54 11-02
16	Bearing/oil seal, kit	MAG side	584 14 05-01
17	Bearing/oil seal, kit	PTO side	584 14 05-02
18	Pressure/vacuum gauge	Pressure testing	531 03 06-23
19	Compression tester	Compression testing	531 03 16-86
19b	Adapter	Size: 10mm	583 84 98-01
20	Assembly fixture	Securing the chain saw	502 51 02-01
21	Crankshaft assembly kit	Assembling crankshaft (MAG side only)	502 50 30-22
22	Hook for fuel filter	Withdrawing the fuel filter	502 50 83-01
23	Assembly kit, piston	Assembling the piston	502 50 70-01
24	Adjustment screwdriver	Adjustment of the carburettor	513 63 56-01
25	Adjustment screwdriver	Adjustment of the carburettor	530 03 55-60

## 5 Service data

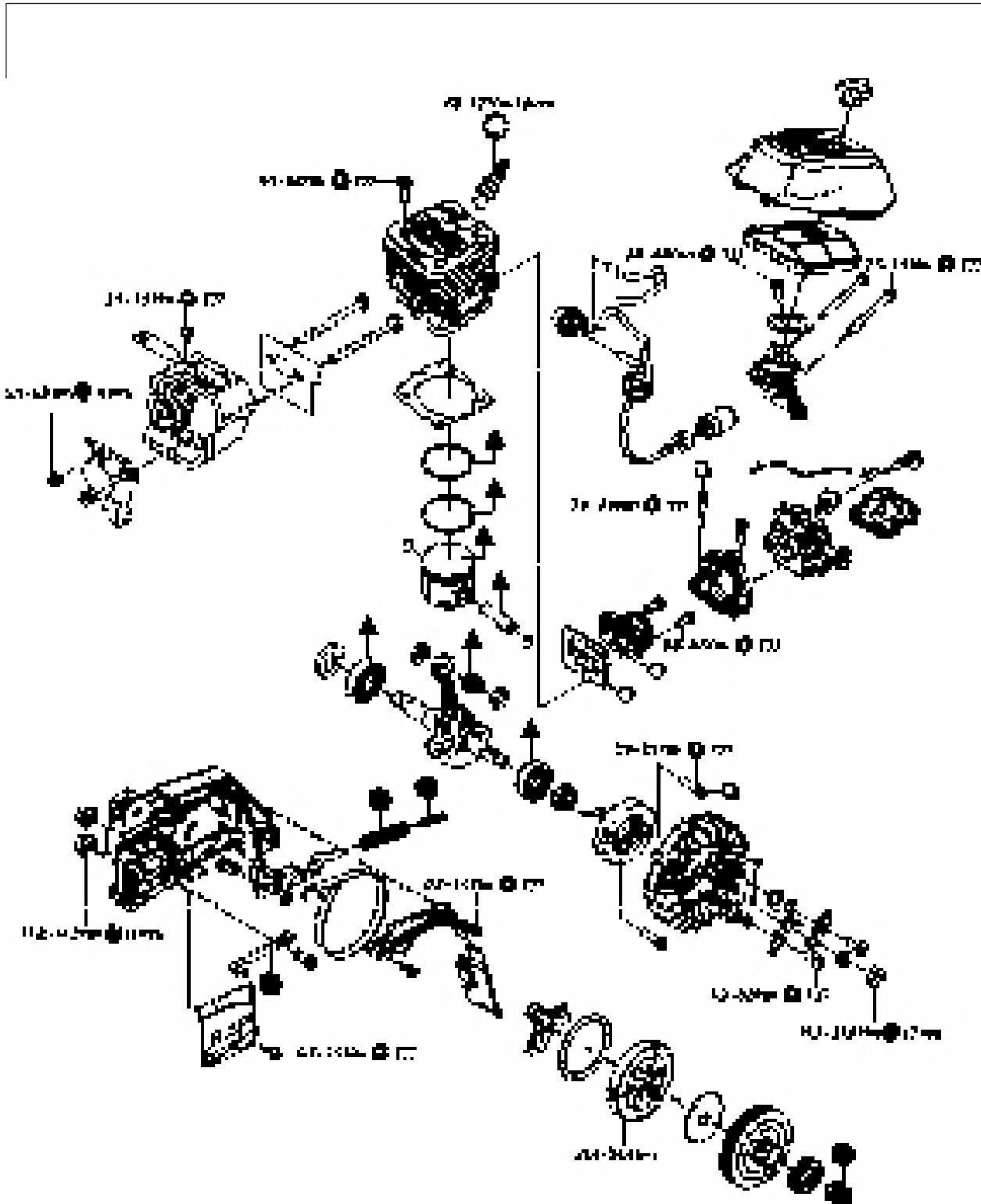

### Key

The numbers by bolted components represent the tightening torque in Nm.

▲ Lubricate with two-stroke oil.

● Lubricate with grease.

n Apply thread lock: Three bond #1342 or Loctite #242.

o Apply thread lock: Three bond #1322 or Loctite #262.

m Apply liquid gasket: #1217F.

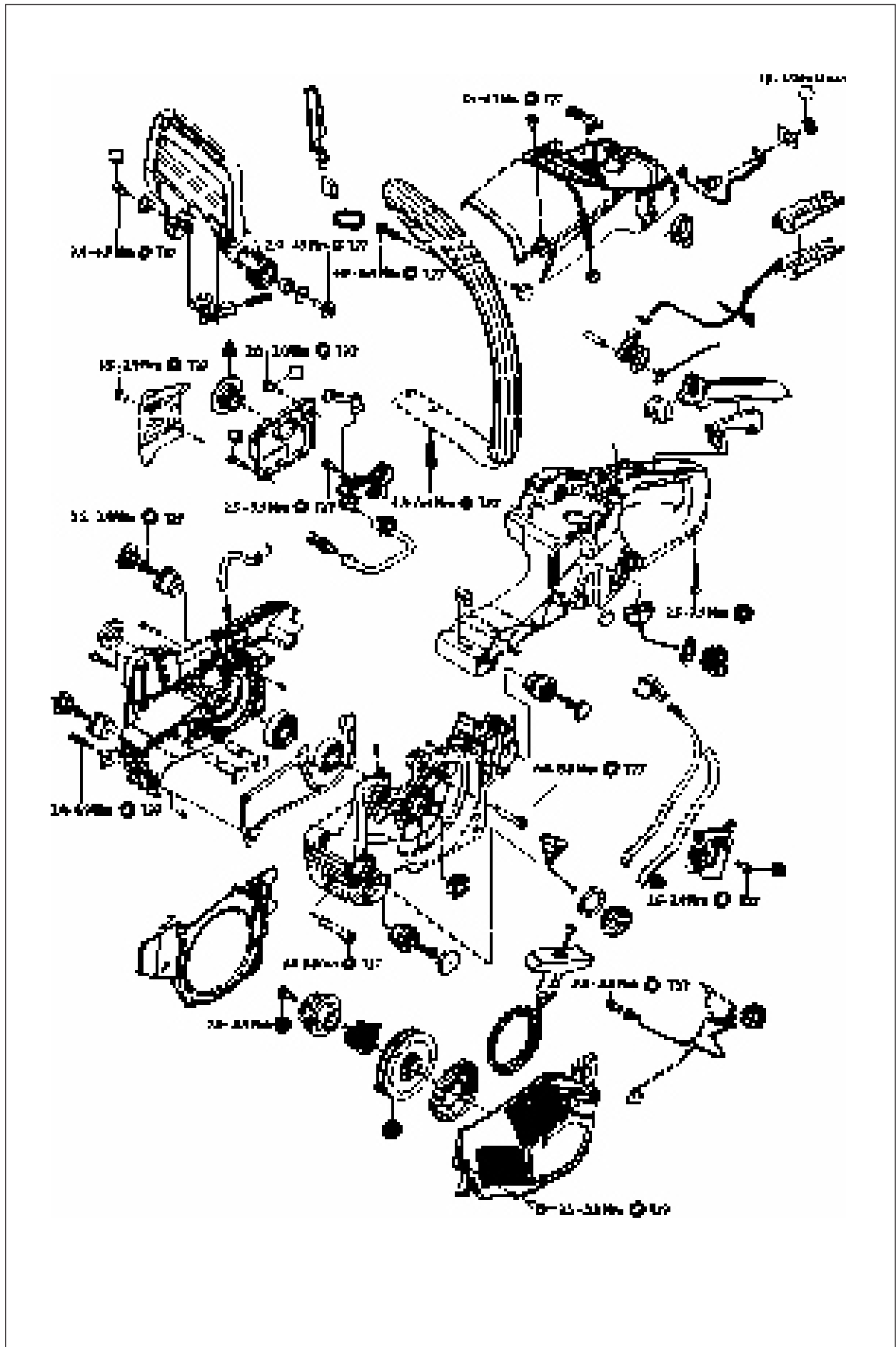

## 6 Safety equipment

### Contents

6.1	Dismantling the chain brake .....	16
6.2	Assembling the chain brake .....	17
6.3	Dismantling the muffler .....	18
6.4	Assembling the muffler .....	19
6.5	Replacing the chain catcher .....	19
6.6	Dismantling the stop switch .....	19
6.7	Assembling the stop switch .....	19
6.8	Resistance test - stop function .....	20
6.9	Dismantling the throttle trigger lockout, throttle trigger and spring .....	21
6.10	Assembling the throttle trigger lockout, throttle trigger and spring .....	22



## 6 Safety equipment

### 6.1 Dismantling the chain brake



**WARNING!**  
Exercise care to ensure the spring does not fly out and cause personal injury. Wear protective goggles.



1

Release the brake by moving the front hand guard backward. Loosen the bar nuts and remove the clutch cover, guide bar and saw chain. See figure 1.

2

Release the tension in the brake spring by pressing down on the lever. See figure 2.

Loosen the screws and carefully remove the covers over the brake spring. See figure 2b.

3

Hold one hand on top of the brake spring and press in a small screwdriver (or special tool 513 63 70-01) into the spring. Carefully bend upwards until the spring is released and it slides onto the screwdriver, see figure 3.

#### Cleaning and inspection

- Clean and check all components carefully. Parts must be replaced if cracked or show signs of other defects. Always use original spare parts.
- Measure the thickness of the chain brake band. It must not be less than 0,6 mm in any place. See figure 4.
- Lubricate the knee joint with grease.

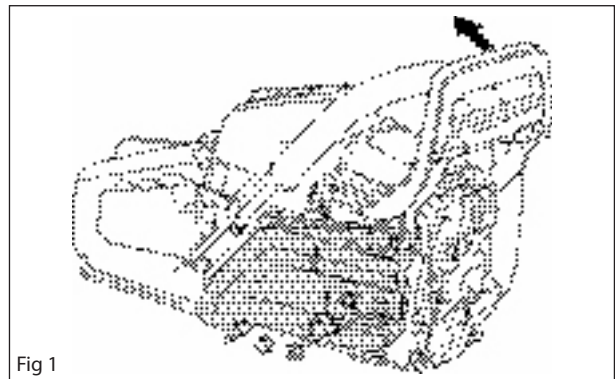

Fig 1

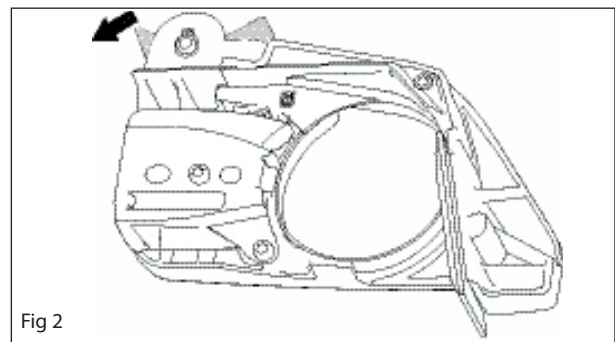

Fig 2

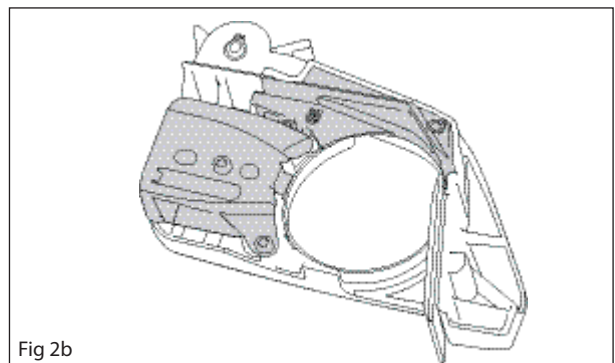

Fig 2b

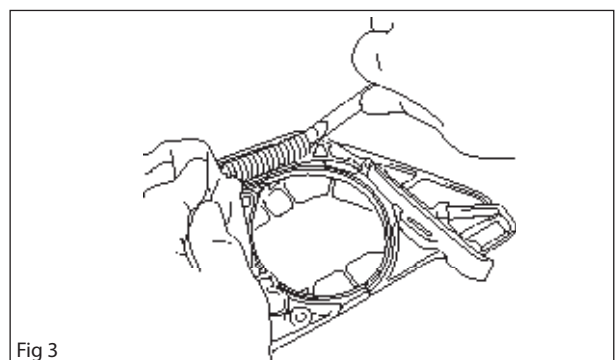

Fig 3

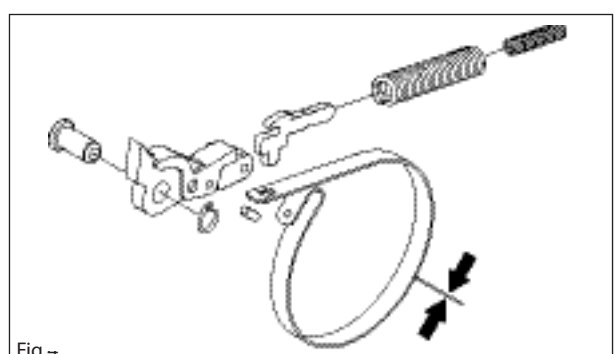

Fig 4

## 6.2 Assembling the chain brake

1

Fit the knee joint and the brake band together (see figure 5). Place the knee joint with the fitted chain brake band in the opening in the clutch cover. The space for the spring in the cover must be lubricated with grease, see figure 5.

2

Compress the spring with a wide screwdriver (or special tool 513 63 70-01) and press it down with your thumb, see figure 6.

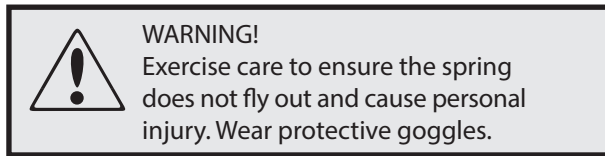

3

Fit the two covers using 0,7-1,5 Nm tightening torque, see figure 7.

4

Tension the spring by pressing down on the lever. See figure 8.

5

Fit the guide bar, saw chain and clutch cover. See figure 9.

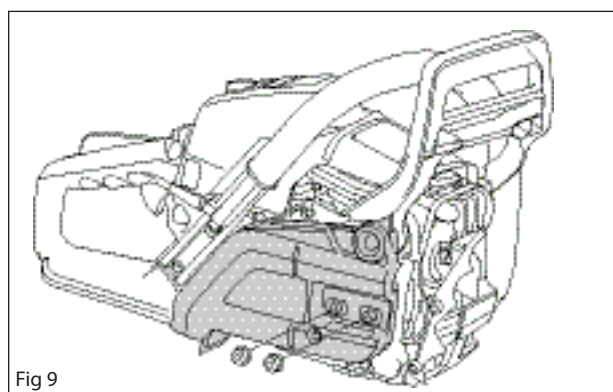
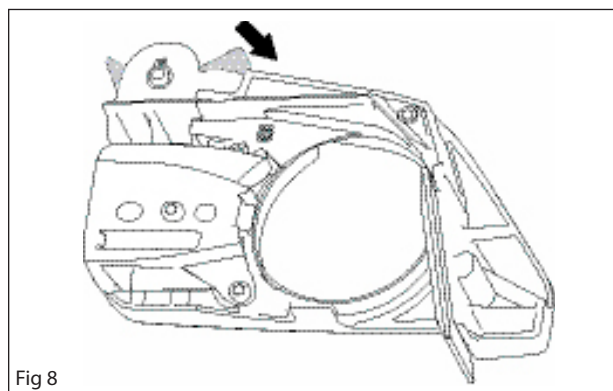
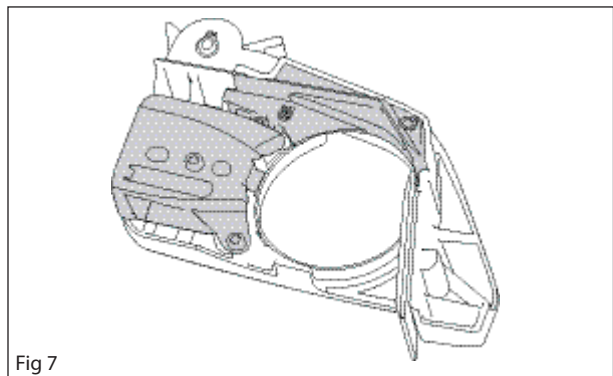
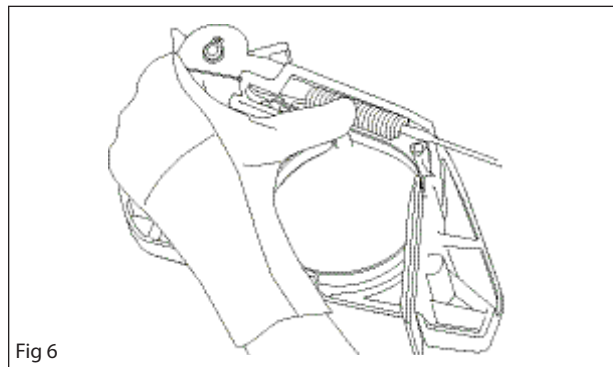
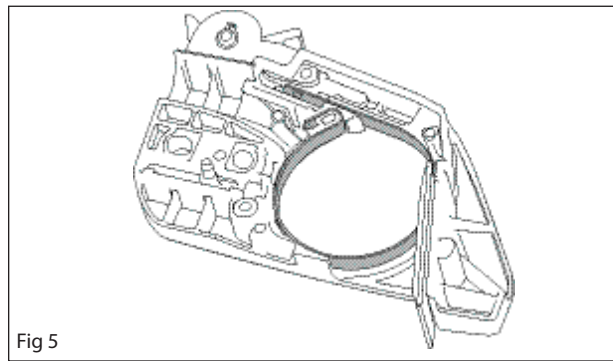

**NOTE!**

After repairing, the chain brake must be inspected in line with the instruction below.

Functional inspection:

Do not turn on the engine when carrying out this inspection.

Guide bar length	Height
13"-18"	45 cm/18"

- Hold the chain saw over a stable surface. The distance between the guide bar and the surface is shown in the table above.
- Let go of the front handle and let the chain saw drop toward the surface underneath.
- When the guide bar hits the surface the chain brake must trigger.



Fig 10

### 6.3 Dismantling the muffler

**WARNING!**

Do not touch the muffler until it has cooled. Risk of burns.

1

Remove the cylinder cover, muffler and gasket. See figure 11.

2

If the muffler is fitted with a spark arrestor mesh, this is removed. If necessary, use the combination spanner to push down the plate edge and remove the spark arrestor mesh, See figure 11.

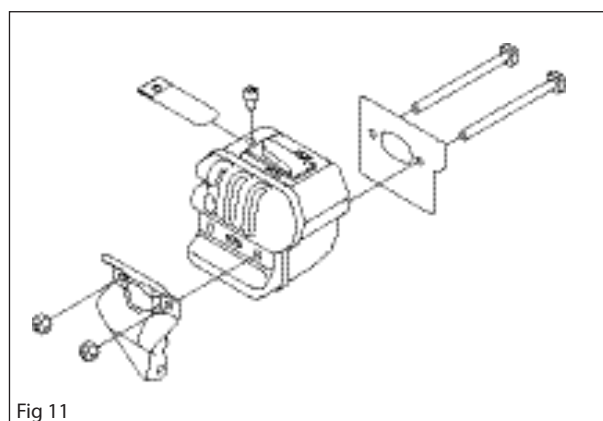

Fig 11

Cleaning and inspection

- Clean and check all components carefully. Parts must be replaced if cracked or show signs of other defects. Always use original spare parts.
- The spark arrestor mesh is best cleaned with a wire brush.
- The mesh must be replaced, if damaged. The chain saw will overheat if the mesh is clogged resulting in damage to the cylinder and piston.
- Never use a chain saw with a clogged or defective muffler.

## 6.4 Assembling the muffler

1

If the muffler is fitted with a spark arrestor mesh, put it in place first. When fitting the mesh, make sure that the mesh is inserted in the right position. If necessary, use the combination spanner to insert the mesh.

2

Fit the:

- gasket
- muffler, tightening torque of 5,9- 6,9 Nm.
- cylinder cover

3

Warm up the chain saw for at least one minute and retighten the screws on the muffler to 5,9 - 6,9 Nm.

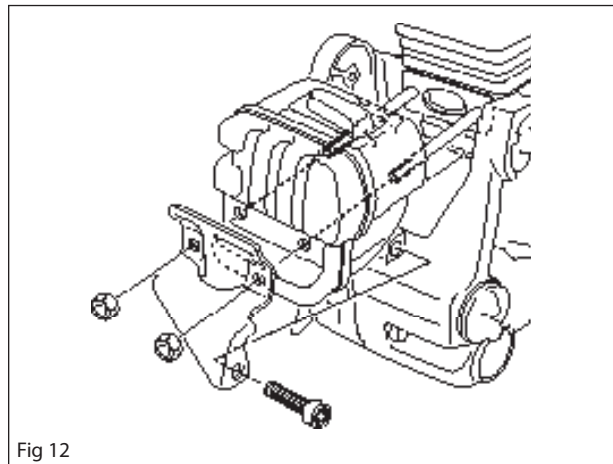

## 6.5 Replacing the chain catcher

A worn chain catcher must always be replaced with a new one. Always use original spare parts.

1

Release the chain brake by moving the front hand guard backward.

Loosen the bar nuts and remove the clutch cover, saw chain and guide bar.

2

Remove the chain catcher and replace it with a new one. Tightening torque 3,4-4,9 Nm.

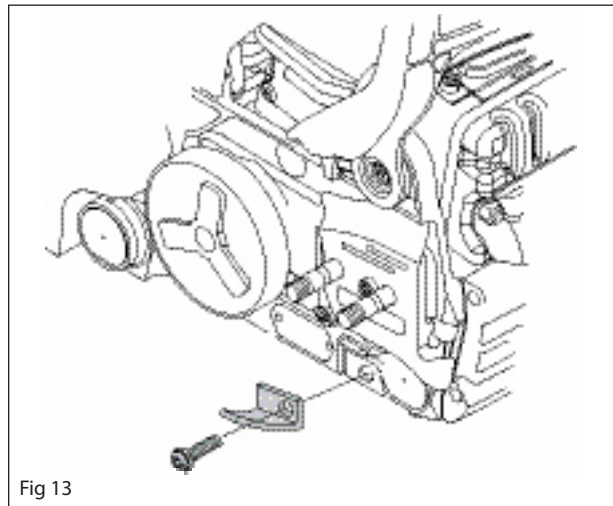

## 6.6 Dismantling the stop switch

1

Carefully remove the stop switch using a flat screwdriver or similar tool. See figure 14.

2

Disconnect the cables.

Cleaning and inspection

- Clean and check the power switch carefully. Parts must be replaced if cracked or show signs of other defects. Always use original spare parts.

## 6.7 Assembling the stop switch

1

Connect the cables. See fig 14.

2

Fit the stop switch.

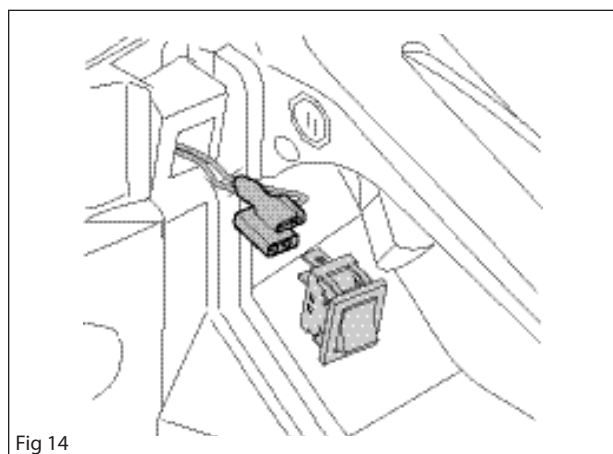

## 6.8 Resistance test - stop switch

1

Dismantle the stop switch as outlined in "6.6 Dismantling the stop switch".

2

Clean the contact areas.

3

Test the resistance by connecting a multimeter to the stop switch. See figure 15. The resistance should be as follows:

"0" pressed in - less than 0.1  $\Omega$ .

"1" pressed in - more than 1000  $\Omega$ .

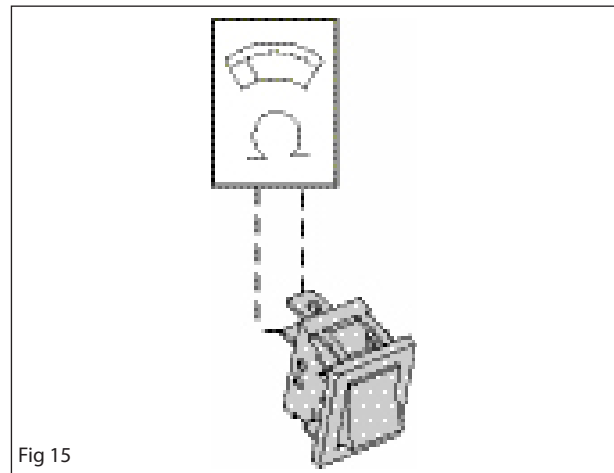

Fig 15

## 6.9 Dismantling the throttle trigger lockout, throttle trigger and spring

1

Loosen the screw on the rear handle. Remove the handle cover. See figure 16.

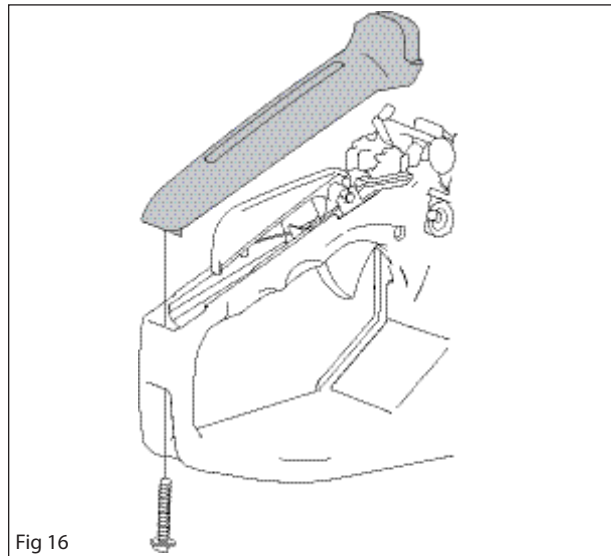

Fig 16

2

Detach the spring and remove the throttle trigger lockout by pulling it upward. See figure 17.

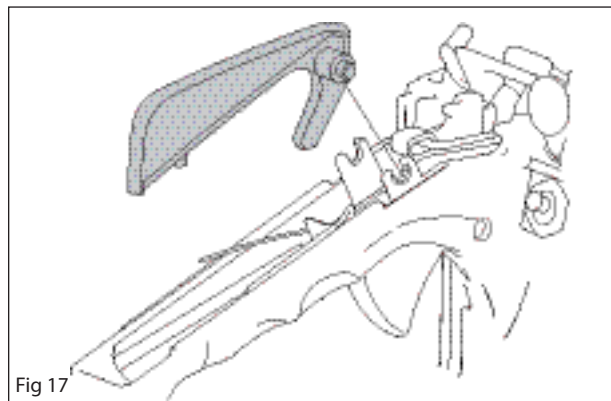

Fig 17

3

Remove the throttle rod from the throttle trigger, see arrow in figure 22. Press out the throttle trigger pin with the help of a punch. Remove the throttle trigger and the spring. See figure 18.

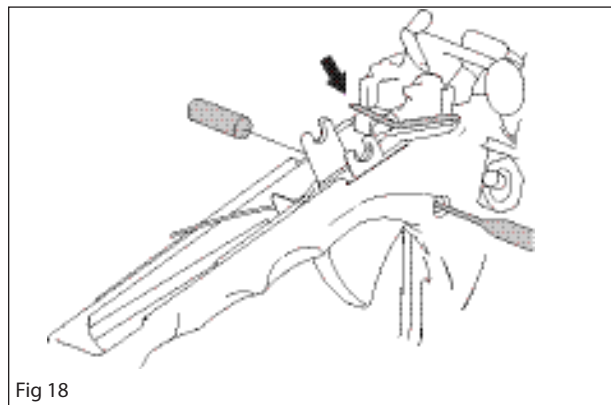

Fig 18

4

Cleaning and inspection

- Carefully clean and check all parts. See figure 19. Parts must be replaced if cracked or show signs of other defects. Always use original spare parts.
- Check that the spring is intact and retains all its tension.

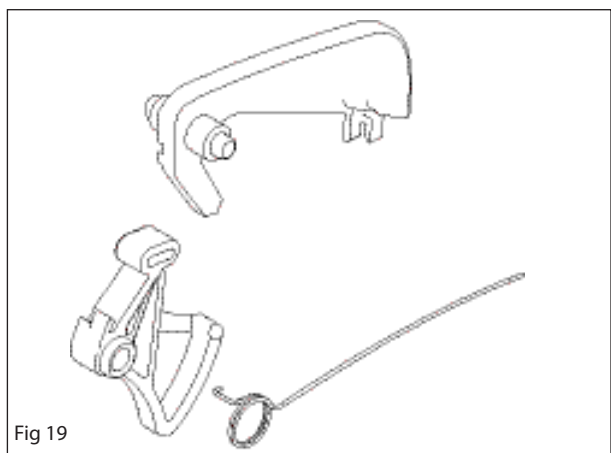

Fig 19

## 6.10 Assembling the throttle trigger lockout, throttle trigger and spring

1

Lubricate the pin and joined surfaces with a light oil. Slide in the throttle control and make sure the spring is fitted as outlined in figure 20.

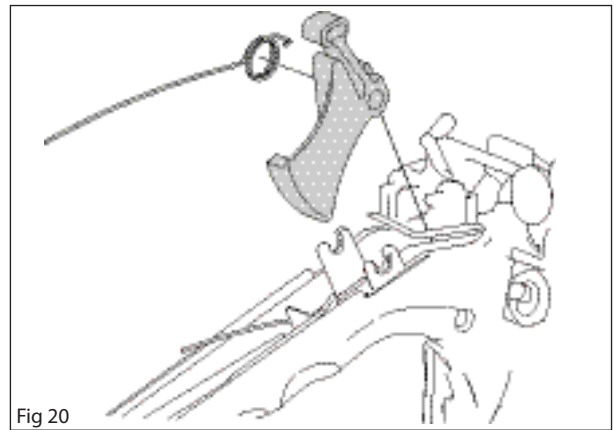

Fig 20

2

Fit the throttle rod on the throttle trigger. Fit the throttle trigger's pin using a punch. See figure 21.

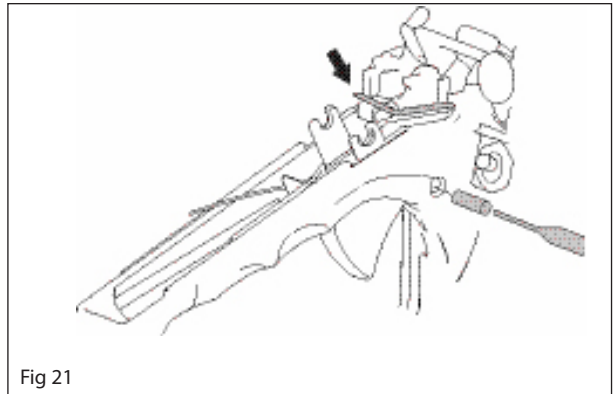

Fig 21

3

Fit the throttle trigger lockout by sliding it on the shaft in the rear handle. See figure 22.

Place the spring according to figure 23.

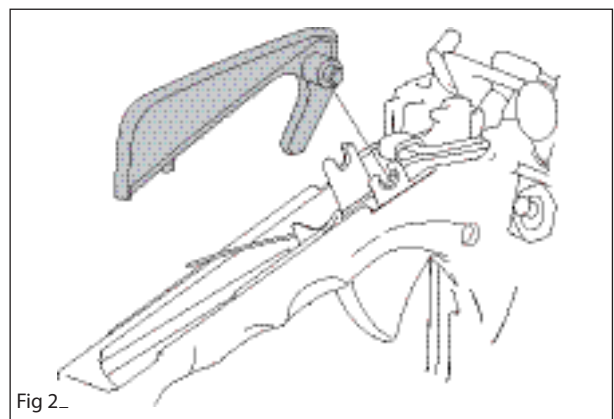

Fig 22

4

Fit the handle cover and fasten the screw. Tightening torque 2,5- 3,9 Nm. See figure 16.

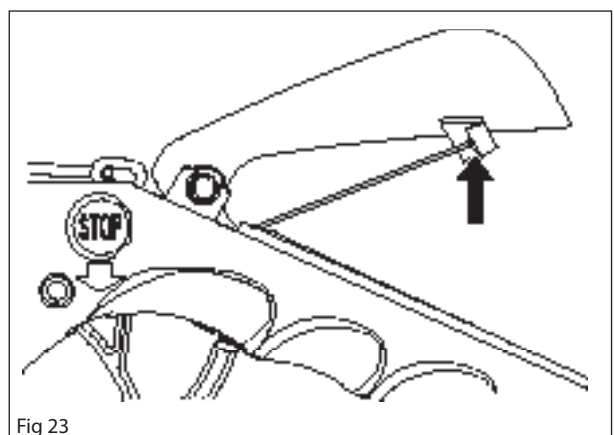

Fig 23

## 7 Repair instructions

### Contents

7.1	Dismantling the starter .....	24
7.2	Replacing a broken or worn starter cord .....	25
7.3	Tensioning the return spring .....	25
7.4	Replacing a broken return spring .....	26
7.5	Starter assembly .....	26
7.6	Removing the cylinder cover .....	27
7.7	Replacing the cylinder cover.....	27
7.8	Dismantling the ignition module and flywheel .....	27
7.9	Assembling the ignition module and flywheel .....	29
7.10	Dismantling the centrifugal clutch .....	30
7.11	Assembling the centrifugal clutch .....	31
7.12	Dismantling the oil pump and screen .....	31
7.13	Assembling the oil pump and screen .....	31
7.14	Dismantling the intake system .....	32
7.15	Assembling the intake system .....	33
7.16	Carburettor .....	34
7.17	Tank unit .....	44
7.18	Vibration damping system .....	45
7.19	Replacing the fuel filter .....	46
7.20	Replacing the fuel hose/return hose .....	46
7.21	Replacing the primer bulb.....	46
7.22	Handle heating system .....	47
7.23	Dismantling the piston and cylinder .....	49
7.24	Assembling the piston and cylinder .....	51
7.25	Leakage/compression testing the cylinder .....	52
7.26	Dismantling the crankshaft and crankcase .....	53



## 7 Repair instructions

### 7.1 Dismantling the starter



**WARNING!**  
If the spring tension is activated on the starter pulley, the spring can fly out and cause personal injury. Wear protective glasses.



1  
Loosen the three screws, which hold the starter against the crankcase and remove the starter. See figure 1.

2  
Pull the cord out about 30 cm and lift it into the notch on the outside of the starter pulley. Release the tension in the return spring by letting the starter pulley rotate anticlockwise. See figures 2 and 3.

3  
Make sure the starter pulley is not tensioned. Loosen the screw in the centre of the pulley and remove the sprocket. See figure 4.

#### Cleaning and inspection

Clean the parts and check:

- The starter cord.
- That the starter pawls on the flywheel are intact, i.e. that they spring back to the centre and move easily.
- To lubricate the return spring using light oil.

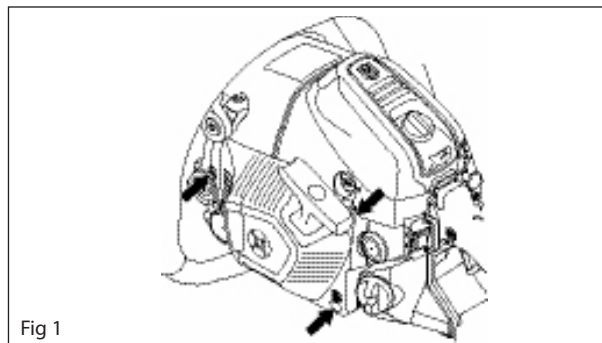

Fig 1

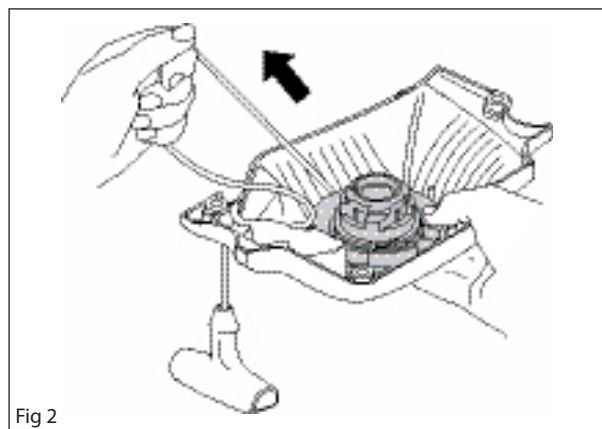

Fig 2

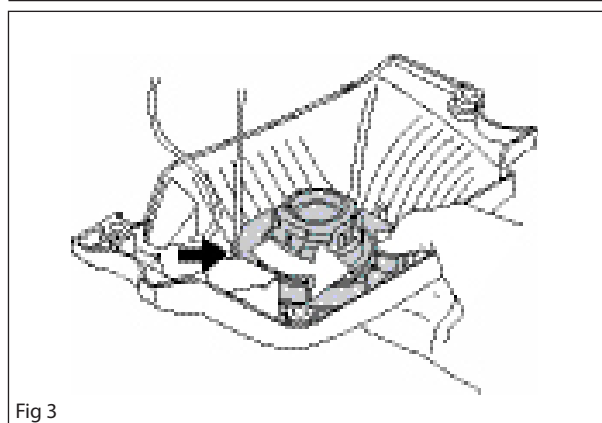

Fig 3

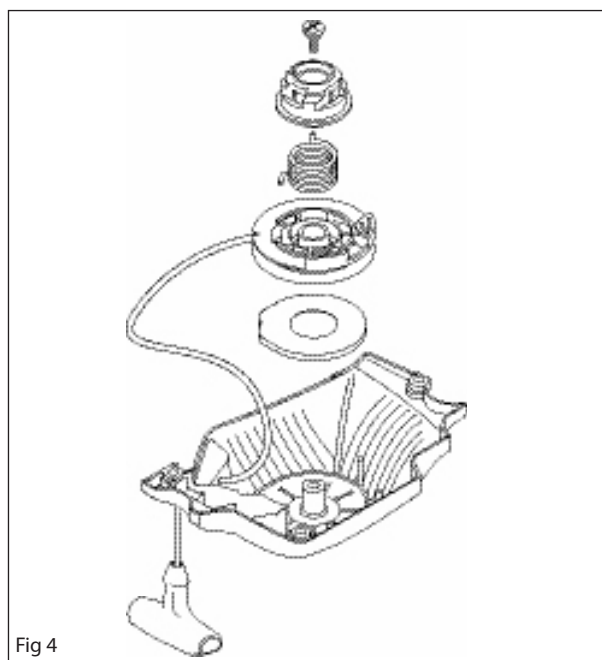

Fig 4

## 7.2 Replacing a broken or worn starter cord

When the starter cord is worn and must be replaced, the tension in the return spring must be released.



**WARNING!**

If the spring tension is activated on the starter pulley, the spring can fly out and cause personal injury. Wear protective glasses.



1

Pull the cord out about 30 cm and lift it into the notch on the outside of the starter pulley. Release the tension on the return spring by allowing the starter pulley to rotate slowly backwards. See figure 5.

2

Loosen the screw in the centre of the pulley and remove the sprocket. See figure 4.

3

When the starter pulley is removed, insert a new starter cord and attach it to the starter pulley. Thread the other end of the starter cord through the hole in the starter housing and starter handle and tie a double knot on the cord. Wind approx. 3 turns of the starter cord on the starter pulley. Turn the starter pulley until it latches into the correct position. Tighten the screw at the centre of the starter pulley. Tightening torque 2,9-3,4 Nm.

Cleaning and inspection:

- Clean and check carefully all components.  
Worn or damaged parts must be replaced.  
Lubricate the return spring with a light oil.

## 7.3 Tensioning the return spring

1

Pull the starter cord up into the notch in the starter pulley and turn the pulley about 3 turns clockwise. Check that the pulley can be turned at least a further 1/2 turn when the starter cord is pulled all the way out. See figure 6.

2

Stretch the line with the handle. Remove your thumb and let the cord spin back. See figure 7.

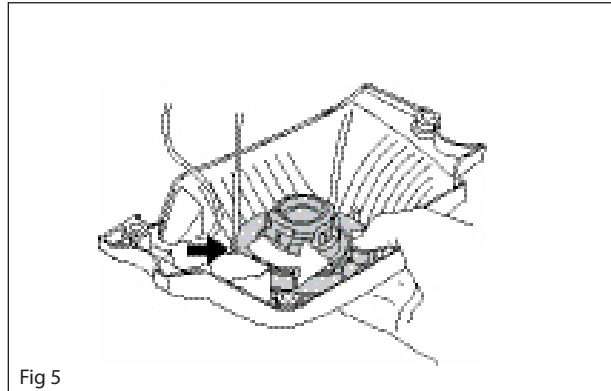

Fig 5

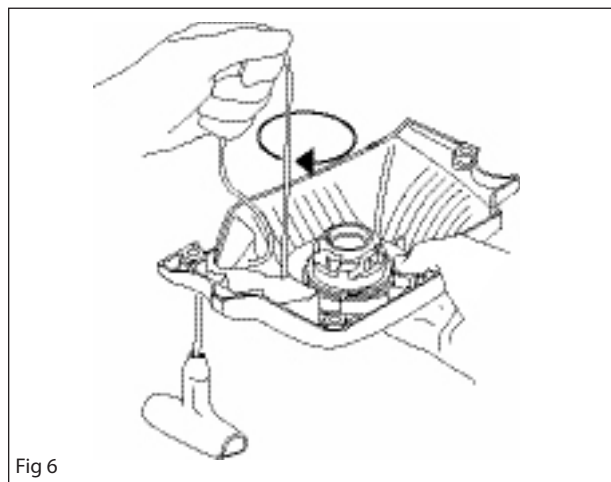

Fig 6

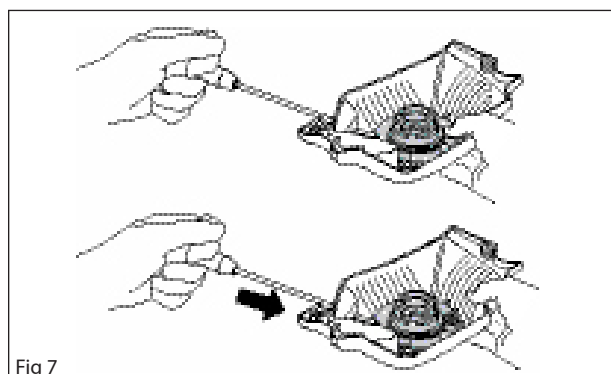

Fig 7

## 7.4 Replacing a broken return spring



**WARNING!**  
Exercise care to ensure the spring does not fly out and cause personal injury. Wear protective goggles.



- 1  
Loosen the screw in the centre of the pulley and remove the sprocket. See figure 4.
- 2  
Remove the broken spring cassette and replace it with a new one.
- 3  
Replace the screw in the centre of the starter pulley. Load the return spring, see "Tensioning the return spring". See also the "Dismantling the starter" chapter.

## 7.5 Starter assembly

- 1  
Position the starter against the crankcase and tighten the screws at a tightening torque of 2,5-3,9 Nm, see figure 8.

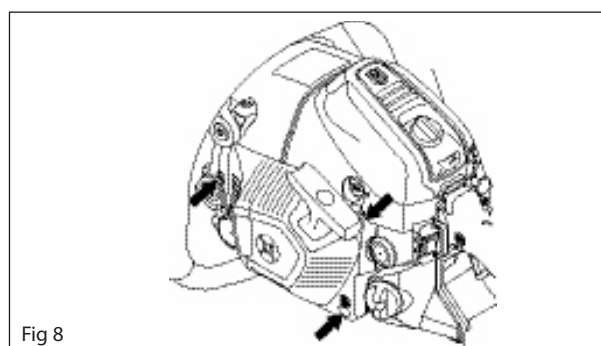

Fig 8

## 7.6 Removing the cylinder cover

- 1  
Remove the air filter cover and air filter.
- 2  
Remove the T-screw (B). Detach the choke rod (A) from the cylinder cover. See figure 8A.
- 3  
Remove the screws (C). Remove the cylinder cover.

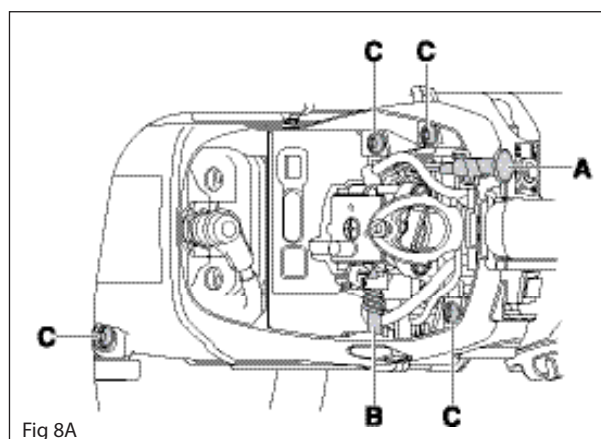

Fig 8A

## 7.7 Replacing the cylinder cover

- 1  
Fit the cylinder cover. Note! be careful not to damage the fuel hose and ignition cable when fitting the cylinder cover. See figure 8A. Screws tightening torque 3.9 - 4.9 Nm.
- 2  
Replace the T-screw and the choke rod. See figure 8B.

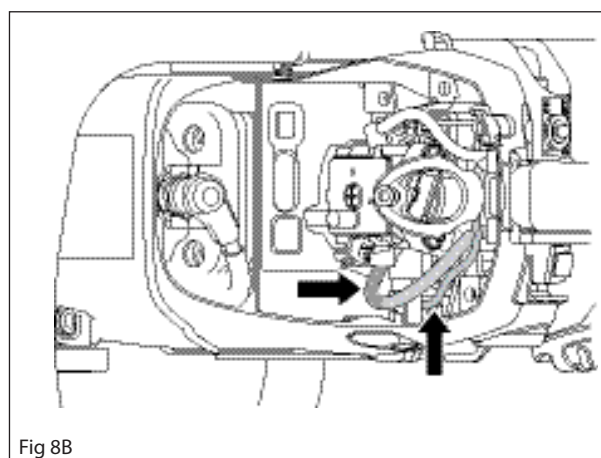

Fig 8B

## 7.8 Dismantling the ignition module and flywheel

1

Remove the cylinder cover. Remove the starter. Snap off the ignition cable from the air guide plate and remove the air guide plate. See figure 9.

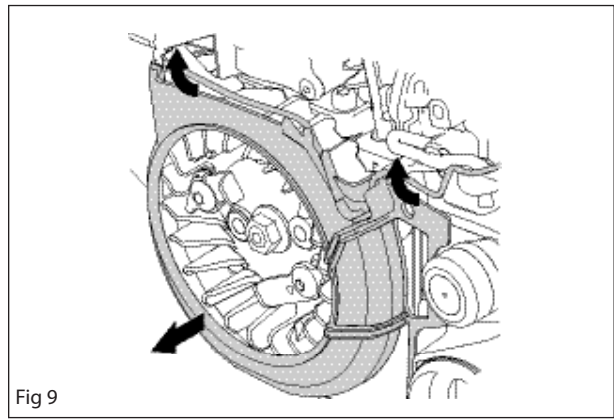

Fig 9

2

Knock out a few of the pins in the tool if it does not match up with the flywheel. Use the tool to hold the flywheel in place while the flywheel nut is loosened using a suitable socket wrench. See figure 10.

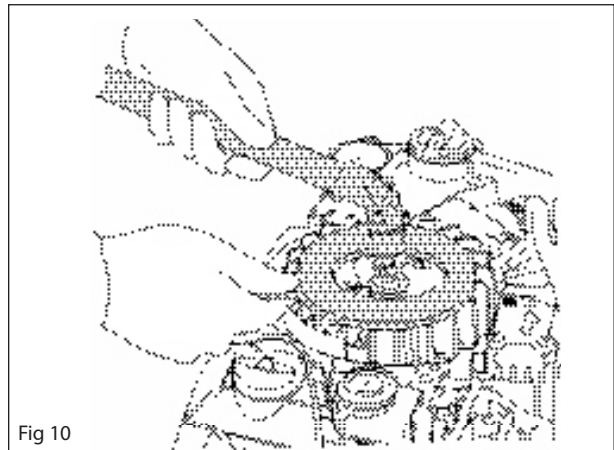

Fig 10

3

use special tool 510 13 89-01 to remove the flywheel. See figure 11.

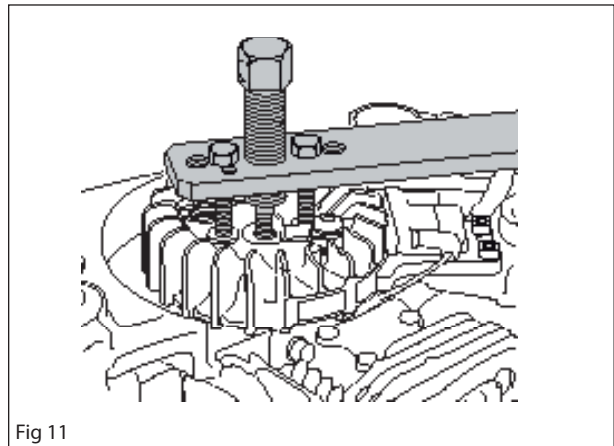

Fig 11

4

Detach the ignition cable and loosen the screws. See figure 12.

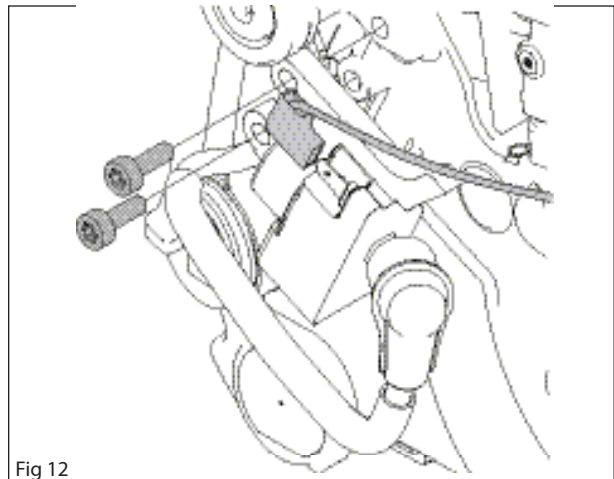

Fig 12

### Cleaning and inspection

- Clean all parts, especially the tapers on the flywheel and shafts.
- Check the flywheel for cracks or any other signs of damage.

## 7.9 Assembling the ignition module and flywheel

1

Place the ignition module in position and fit the screws. See figure 13. Do not tighten the screws.

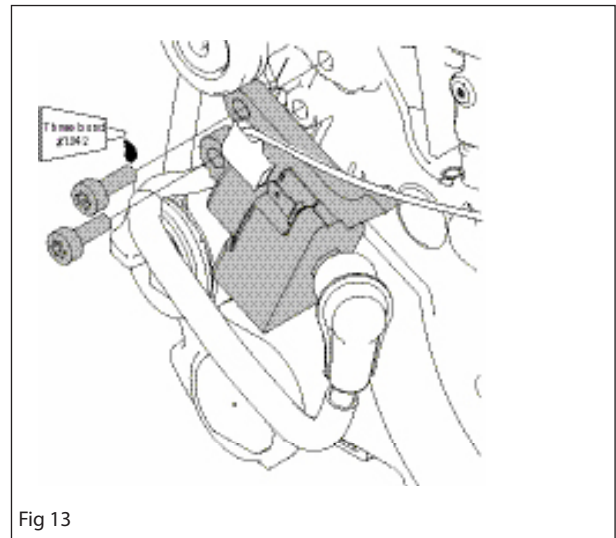

Fig 13

2

Fit the flywheel onto the crankshaft pin. Turn the flywheel until the key fits into the key slot on the shaft. See figure 14.

Tighten the nut for the flywheel.

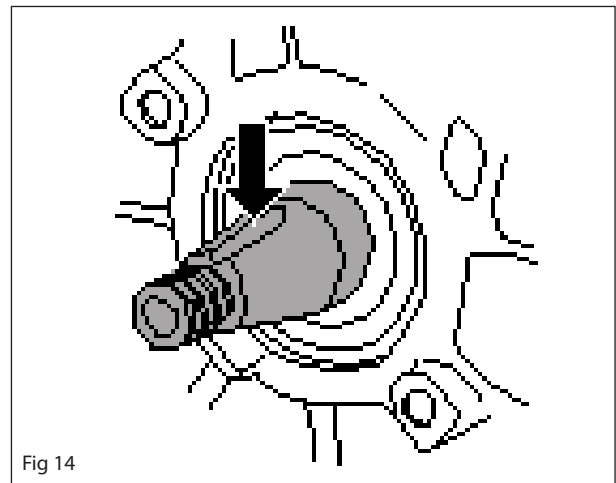

Fig 14

3

Insert the plastic air gap tool, at a thickness of  $0,4 \pm 0,1$  mm, between the lugs on the ignition module and flywheel. See figure 15.

Turn the flywheel so that the magnets are positioned opposite the ignition module. Tighten the screws, at a tightening torque of 2,5-3,9 Nm. Remove the plastic air gap tool.

4

Attach the ignition cable to the ignition module.

5

Then fit the:

- air guide plate and press the cable in place.
- starter, at a tightening torque of 2,5-3,9 Nm.
- cylinder cover and air filter cover.

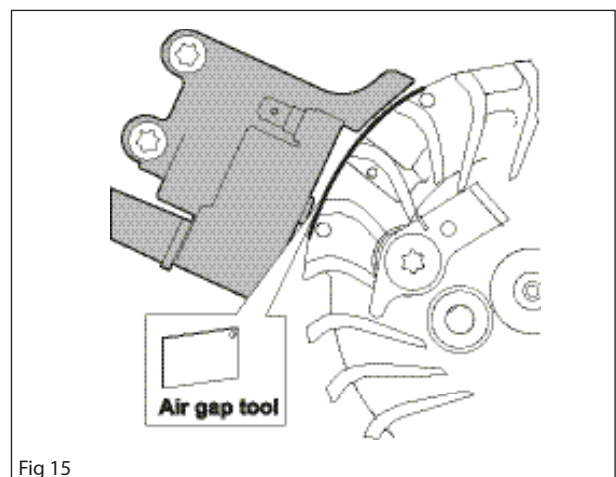

Fig 15

## 7.10 Dismantling the centrifugal clutch

1

Remove the cylinder cover. Release the brake by moving the front hand guard backwards. Loosen the bar nuts and remove the clutch cover, saw chain and guide bar. See figure 16.

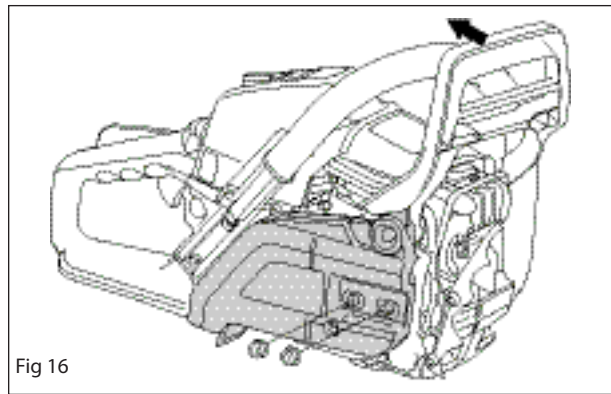

Fig 16

2

Remove the spark plug hat and the spark plug. Insert the piston stop (581 40 85-01). See figure 17.

3

Loosen the clutch using tool 513 63 60-01 and a suitable socket wrench. Turn the clutch clockwise to loosen it. See figure 17.

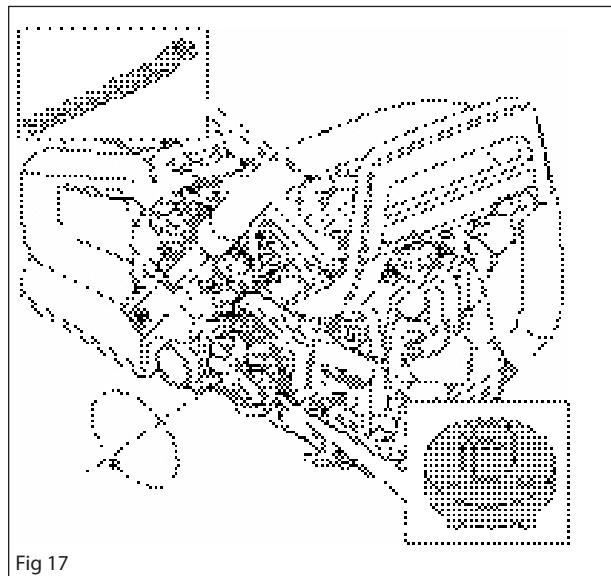

Fig 17

4

Dismantle the clutch according to figure 18. Carefully remove the clutch spring.

### NOTE!

Be careful with the clutch spring, as opening them too much can result in material damage.

### Cleaning and inspection

- Clean and check all parts carefully. Parts must be replaced if cracked or showing signs of other defects. Always use original spare parts.
- Check the thickness of the clutch shoes by measuring them with slide callipers across the whole clutch hub. If the thickness is below 60 mm, the clutch must be replaced. See figure 19.

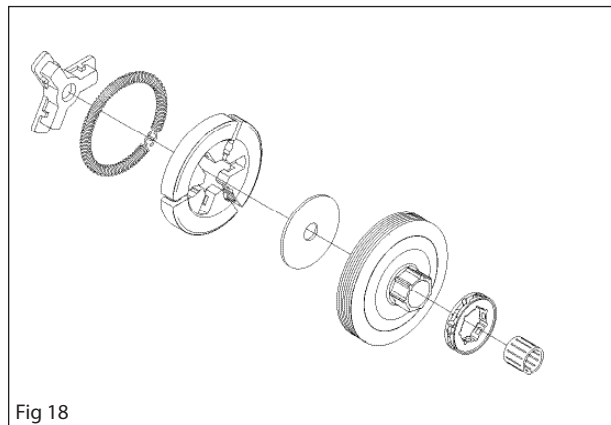

Fig 18

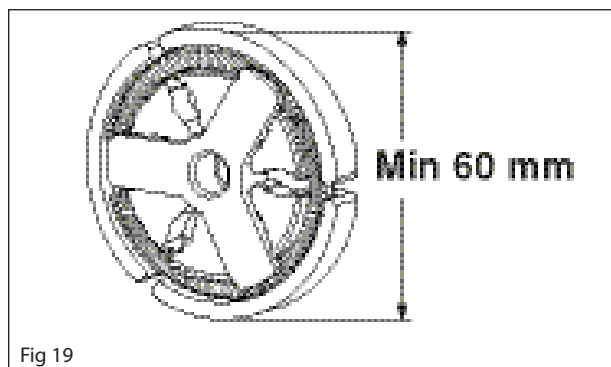

Fig 19

### 7.11 Assembling the centrifugal clutch

1

Use special tool 513 63 65-01 and assemble the clutch according to figure 20.

2

Screw in the clutch (anti-clockwise) until it stops. Then tighten the clutch using tool 513 63 60-01 and a suitable socket wrench or combination spanner. Tightening torque of 29,4-34,4 Nm.

3

Remove the piston stop and fit the spark plug using a tightening torque of 8,8-12,7 Nm. Attach the spark plug hat.

Then fit the:

- cylinder cover
- guide bar
- saw chain
- clutch cover

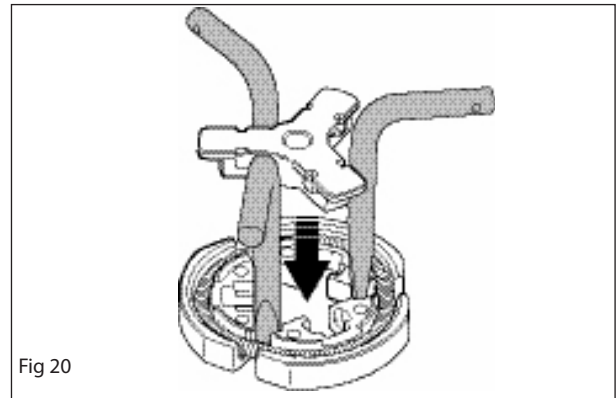

Fig 20

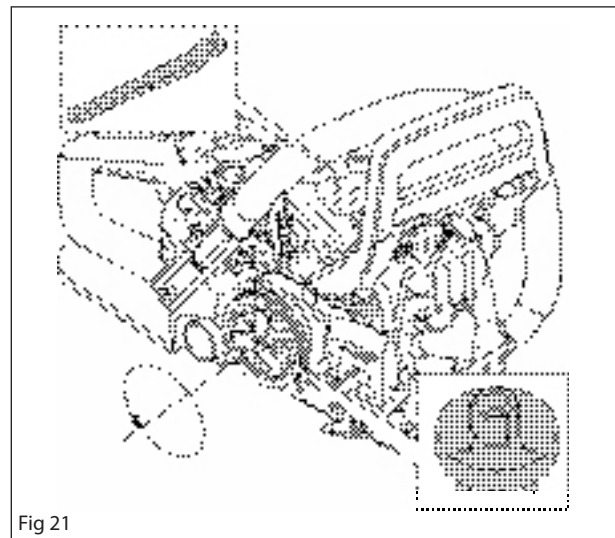

Fig 21

### 7.12 Dismantling the oil pump and screen

1

Empty and clean the saw chain oil tank. Dismantle the centrifugal clutch as outlined in "Dismantling the centrifugal clutch".

2

Remove the clutch.

3

Remove the chain guide plate and the oil pump cover. See figure 22.

4

Remove the oil pump from the crankcase together with the oil pressure hose. See figure 22.

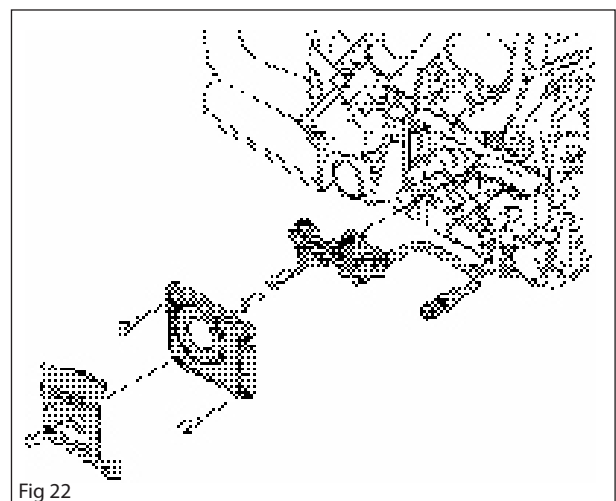

Fig 22

Cleaning and inspection

- Clean and check all parts carefully. Parts must be replaced if cracked or showing signs of other defects. Always use original spare parts.
- Lubricate all moving parts with saw chain oil.



### 7.13 Assembling the oil pump and screen

- 1  
Lower the oil filter in place and replace the oil pump as outlined in figure 22 and tighten the screws.
- 2  
Fit the pump drive wheel and apply three bond #1322 (thread lock) to the screws. Fit the chain guide plate. Tightening torque 1,5-2,9 Nm. See figure 22B.
- 3  
Fit the clutch. See the "Assembling the centrifugal clutch" chapter.
- 4  
Fit the saw chain, guide bar and clutch cover.
- 5  
Adjust the oil pump. See Figure 23.

	<p><b>WARNING!</b> Insufficient saw chain lubrication can result in chain breakage, which can cause serious personal injury.</p>
---	--

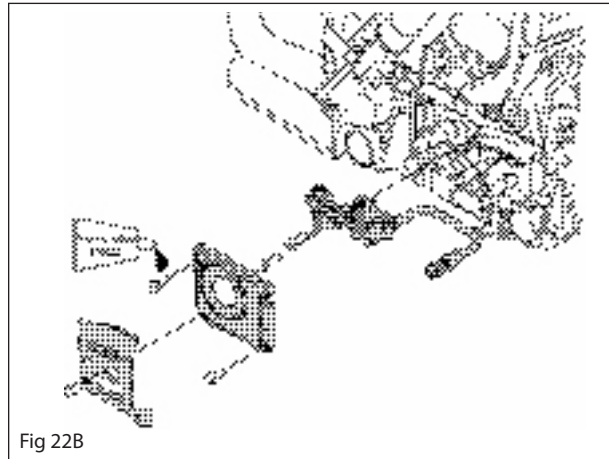

Fig 22B

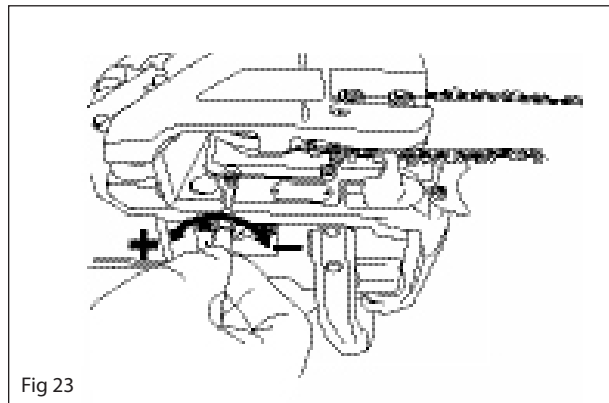

Fig 23

### 7.14 Dismantling the intake system

The intake system consists of:

- The inlet pipe assy, B
- The intake flange, C

See Figure 24.

- 1  
Dismantle the cylinder cover.
- 2  
Dismantle the air filter, the filter holder, the cable from the intake flange holder.
- 3  
Dismantle the carburettor as outlined in "Dismantling the carburettor".
- 4  
Dismantle the intake flange, C.
- 5  
Dismantle the inlet pipe assy, B.

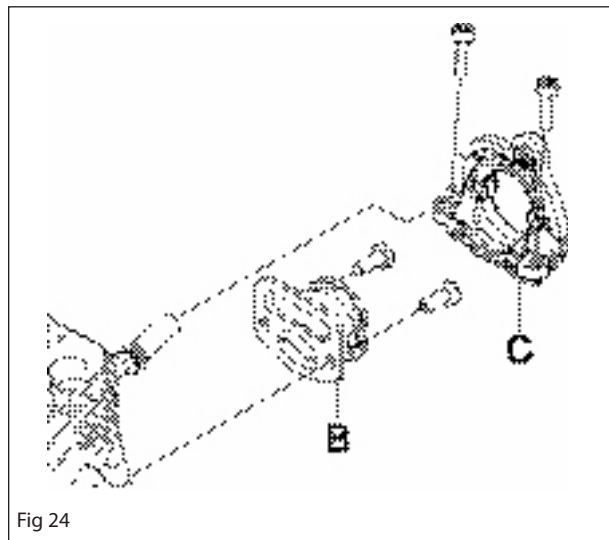

Fig 24

#### Cleaning and inspection

- Clean and check all parts carefully. Parts must be replaced if cracked or showing signs of other defects. Always use original spare parts.



## 7.15 Assembling the intake system

- 1  
Fit the inlet pipe assy, B. See figure 25.
- 2  
Fit the intake flange, C. See figure 25.
- 3  
Fit the carburettor and the throttle rod as outlined in "Assembling the carburettor".
- 4  
Fit the air filter, the filter holder, the cable from the intake flange holder.
- 5  
Fit the cylinder cover.

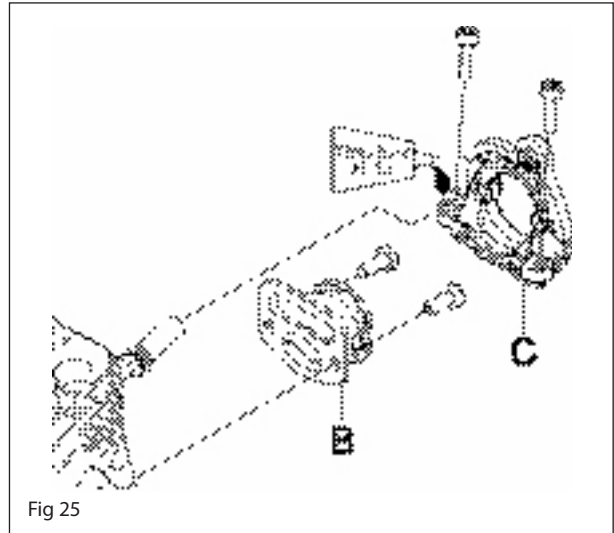
**NOTE!**

It is very important that the intake system is sealed. Otherwise the engine may seize up.

## 7.16 Carburettor



**WARNING!**

The fuel used in the chain saw has the following hazardous properties:

1. The fluid and its vapour are poisonous.
2. Can cause skin irritation.
3. Is highly inflammable.

### Description

The images for this description do not correspond to the carburettor on the chain saw. They purely show the principle for the design and function. The carburettor is based on three sub-systems:

### Metering unit

The needles and the fuel's control functions are located in the metering unit A. Here the correct fuel amount is adjusted for the current speed and power output. See figure 26.

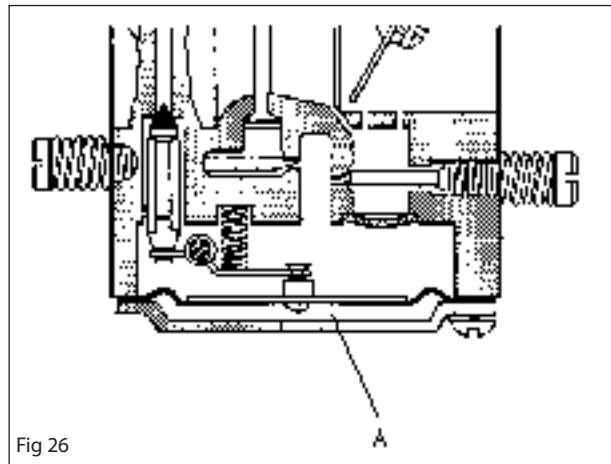

Fig 26

### Mixing venturi

The mixing venturi B houses the choke, throttle valve and diffuser jets. Here, air and fuel are mixed to create a fuel-air mix that can be ignited by the ignition spark. See figure 27.

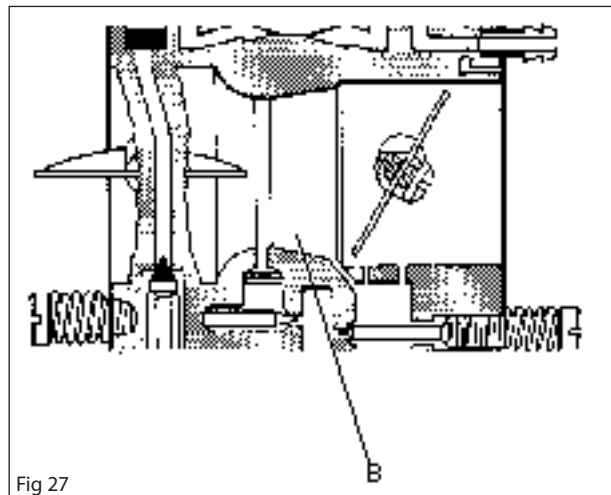

Fig 27

### Pump unit

In the pump unit C fuel is pumped from the fuel tank to the carburettor's metering unit. One side of the pump diaphragm is connected to the crankcase and pulses in time with the pressure changes in the crankcase. The other side of the diaphragm pumps the fuel. See figure 28.

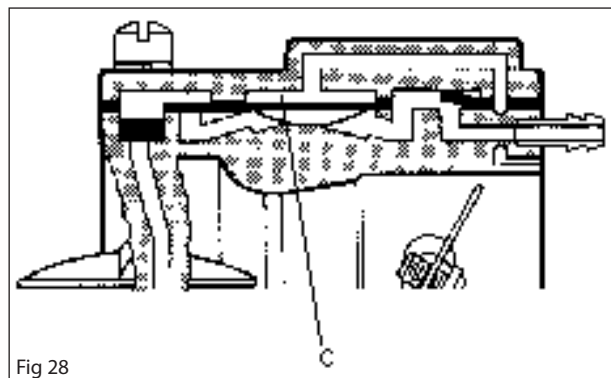

Fig 28

### Function

The carburettor functions differently in the following modes:

#### Cold start mode

In cold start mode the choke valve D is completely shut. This increases the vacuum in the carburettor and fuel is easier to suck from all the diffuser jets E, F and G. Throttle valve H is partly open. See figure 29.

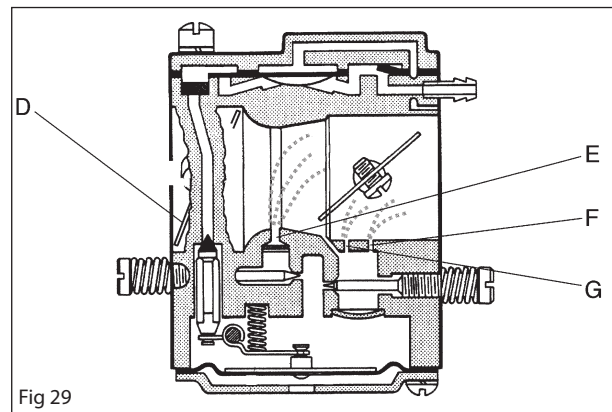

#### Idle mode

In idle mode throttle valve H is shut. Air is sucked in through an aperture in the throttle valve and a small amount of fuel is supplied through the diffuser jet F. See figure 30.

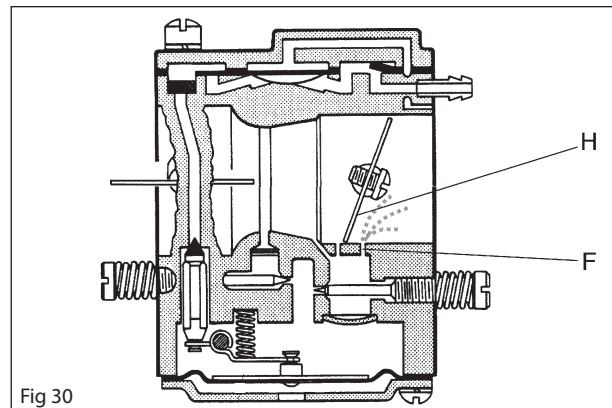

#### Part throttle mode

In part throttle mode the throttle valve H is partly open. Fuel is supplied through the diffuser jets F and G. See figure 31.

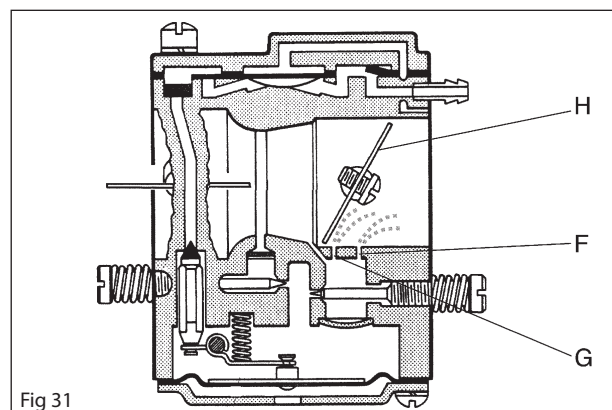

#### Full throttle mode

In full throttle mode both valves are open and fuel is supplied through all three diffuser jets E, F and G. See figure 32.

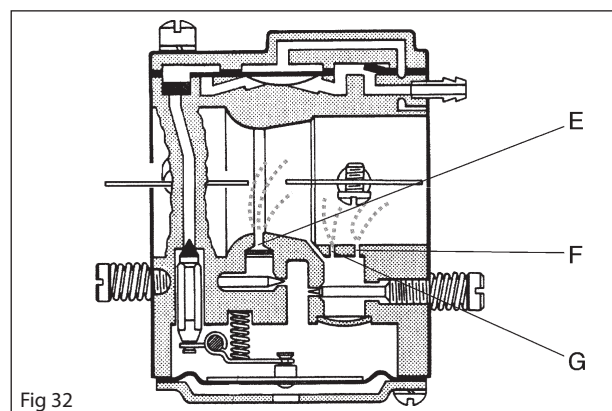

Dismantling the carburettor

1

Remove the cylinder cover and the air filter.

2

Remove the manifold. See figure 33.

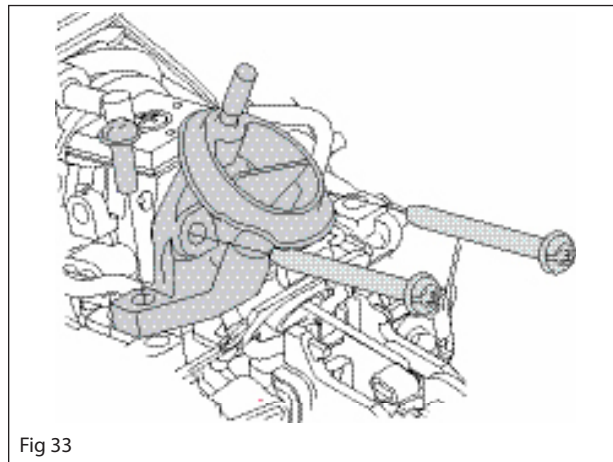

Fig 33

3

Detach hose A, B and C from the carburettor. See figure 34.

4

Unhook the choke and throttle rods. See figure 34B.

5

Remove the carburettor.

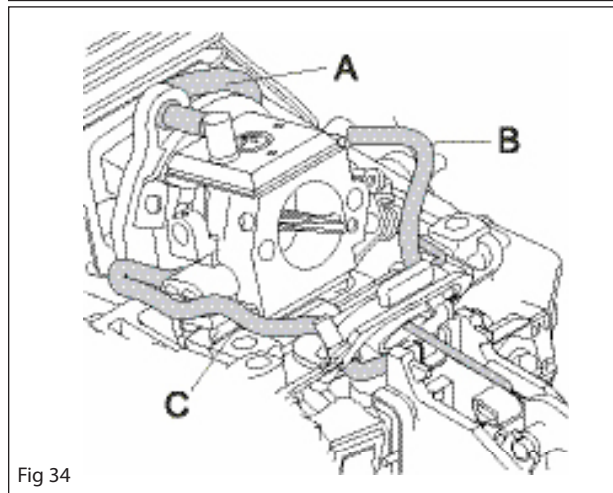

Fig 34

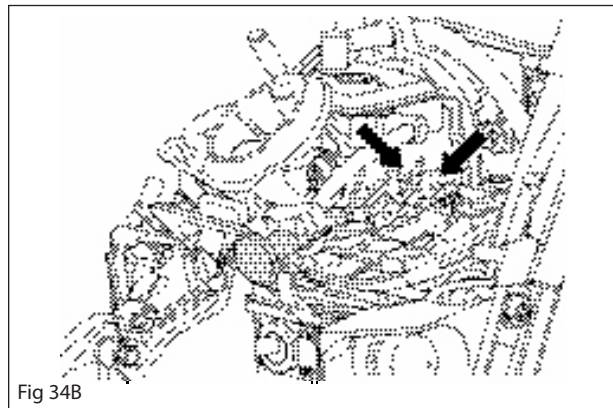

Fig 34B

6

Dismantle the pump cover H. Remove the control diaphragm J and gasket K. See figure 35.

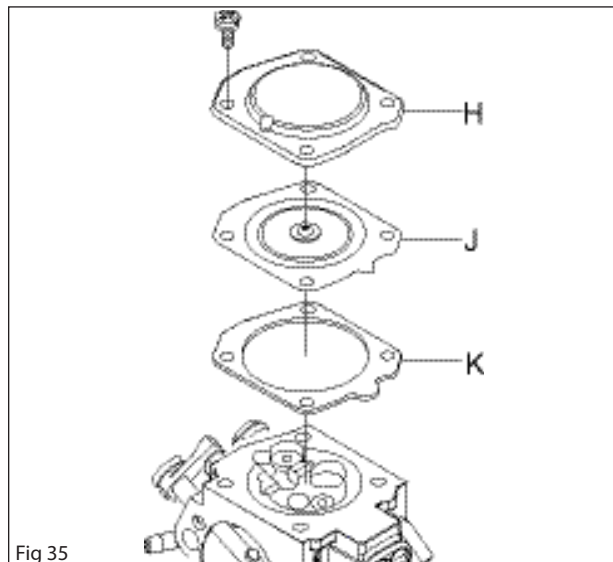
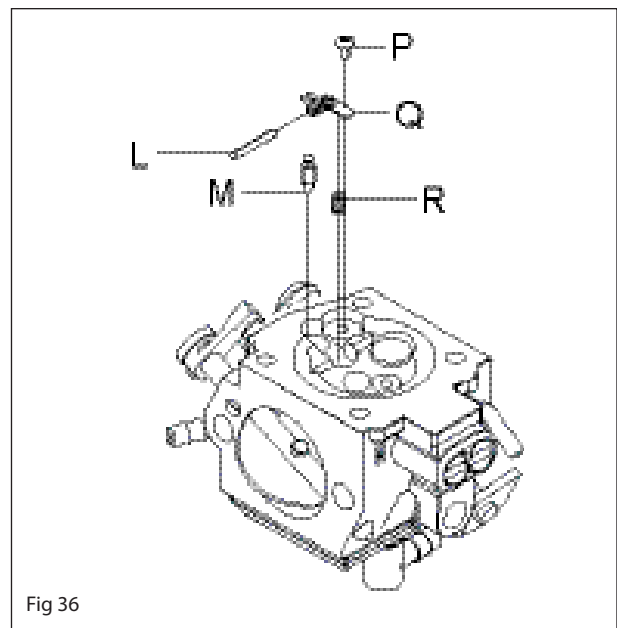

Fig 35

- 7  
 Remove screw P and needle valve M with lever arm Q, shaft L and spring R. See figure 36.



- 8  
 Remove screw Z and remove gasket Y and diaphragm X. See figure 37.

- 9  
 Use a needle or similar device and carefully pull up the fuel screen (W). See figure 37.

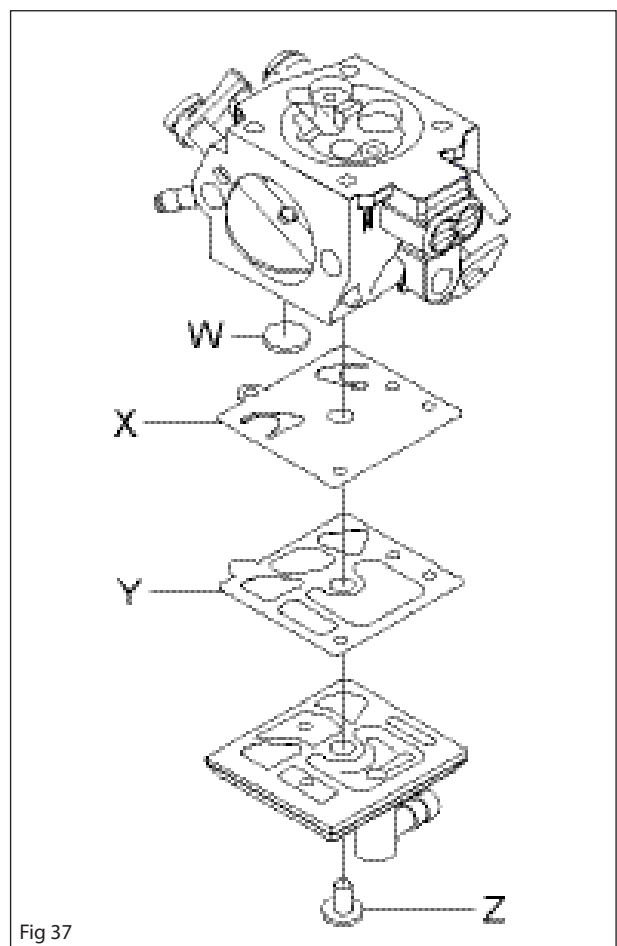

10

If necessary, dismantle throttle valve T and the High (S) and Low (P) jet screws valve. Remove the shafts with lever arms and springs.

Cleaning and inspection

Clean all units in clean petrol.

Use compressed air to dry the petrol on the components. Direct the air through all channels in the carburettor housing and ensure that they are not blocked. Check the following:

1. That the gasket, pump and control diaphragms are undamaged.
2. That there is no play on the throttle and choke valve shafts.
3. That the needle valve M and its lever arm Q are not worn. See figure 36.
4. That the inlet manifold is intact. See figure 38.
5. That the fuel screen W is intact and clean. See figure 39.
6. That the tips of the high and low jet screws are not damaged.

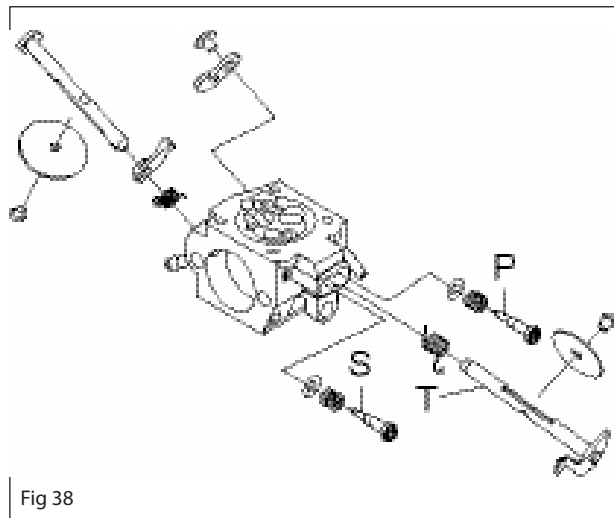

Fig 38

Assembly

Observe cleanliness when assembling the carburettor. The slightest contamination can result in downtime.

1. If the throttle valve with shaft, lever arm and spring is removed, this must be assembled. The spring is tensioned 1-2 turns. Lubricate the shaft bearings using a light oil. See figure 38.
2. Fit the fuel screen W using the handle of a small screwdriver. See figure 39.
3. Fit the gasket Y, diaphragm X in the carburettor as well as the cover. Screw in place screw Z as outlined in figure 39.

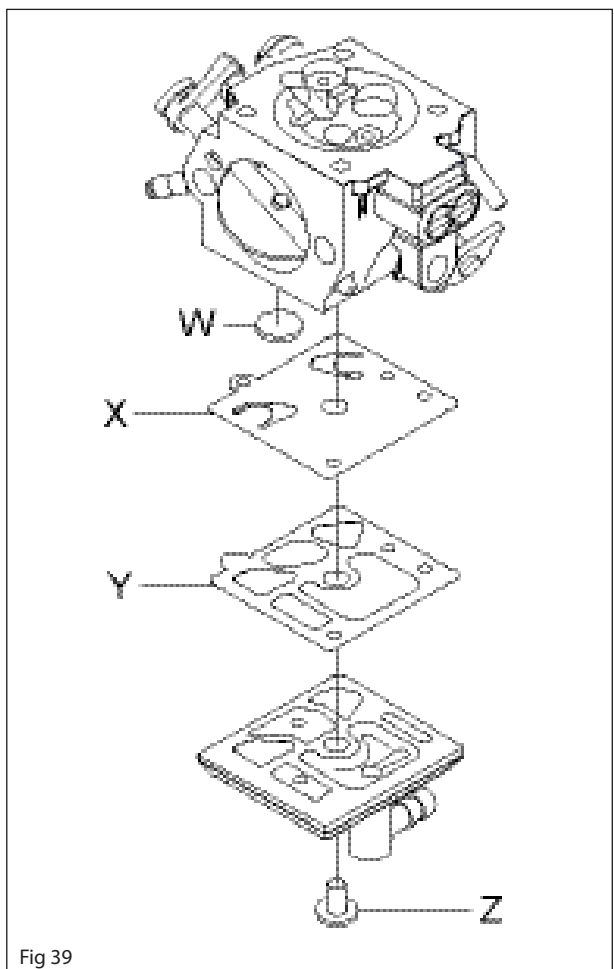
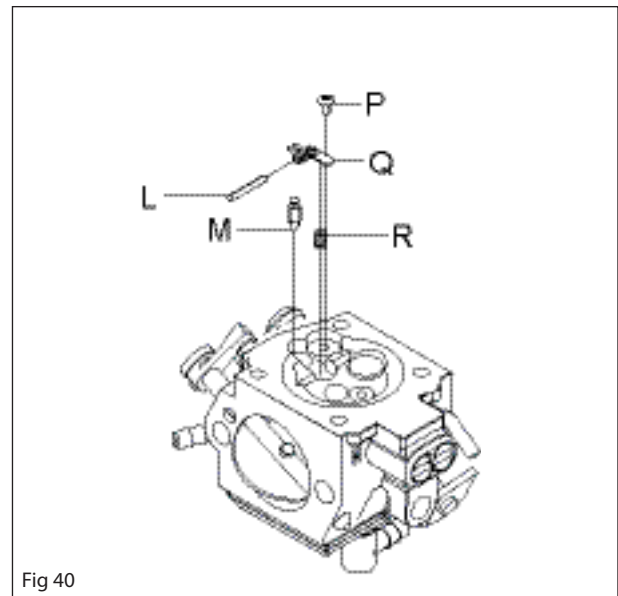
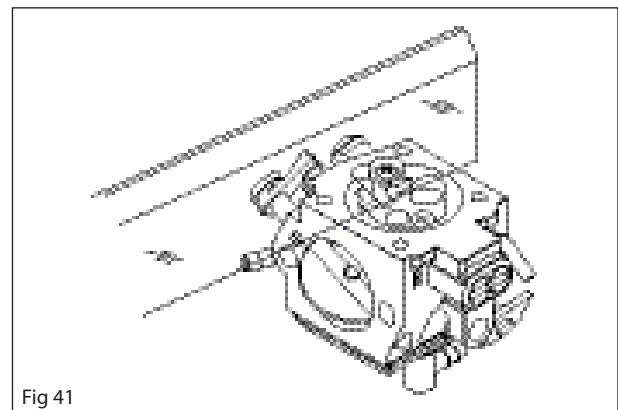

Fig 39

4. Assemble needle valve M with lever arm Q, shaft L and spring R, and tighten screw P. See figure 40.



5. Check using a ruler or the like that the lever is level with the assembly plane on the cover. If necessary, the lever arm can be bent, see figure 41.



7. Fit gasket K, the control membrane J and the pump cover H. See figure 42.
8. Carry out a pressure test. See "Pressure testing the carburettor".

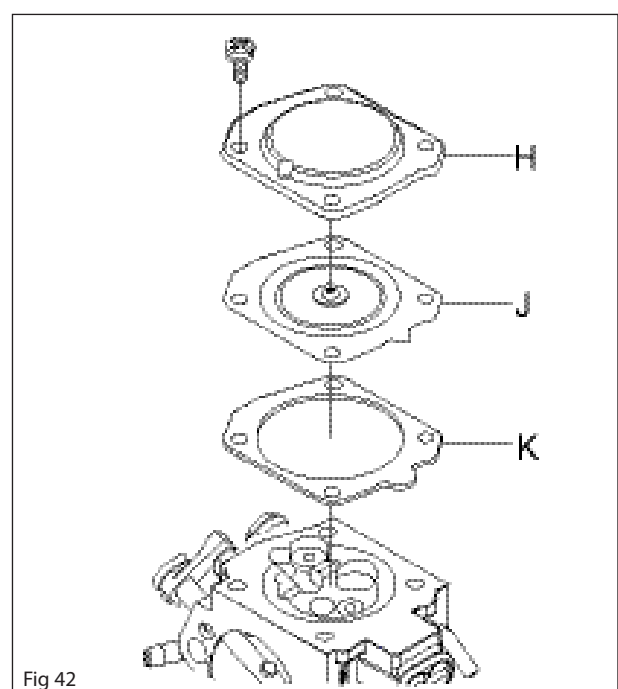

Pressure testing the carburettor

Pressure testing should be carried out with the carburettor fully assembled. Testing should always be carried out after the carburettor has been repaired, but a test can also be made for troubleshooting before dismantling.

Option 1

Carry out the check as follows:

- 1  
Connect pressure tester to the carburettor fuel inlet.
- 2  
Submerge the carburettor into a container with water. See figure 43.
- 3  
Pump up the pressure to 20 kPa.
- 4  
No leakage is permitted. If leakage occurs refer to the table below.

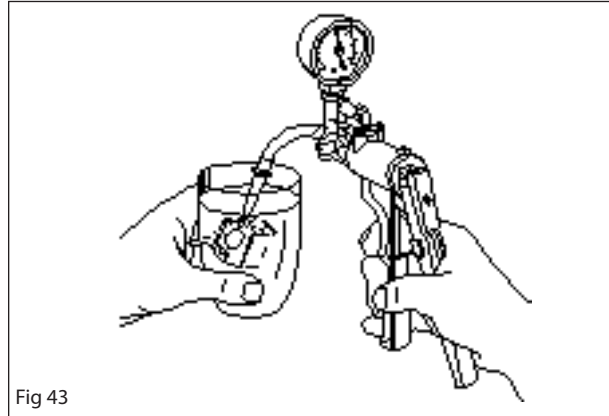

Fig 43

Option 2

Carry out the check as follows:

- 1  
Plug the connections to the fuel inlet.
- 2  
Create a vacuum to the purge nipple on the carburettor. No leakage is permitted. In the case of leakage, leakage spray can be used even if it is difficult. Try and identify where the spray is absorbed. It can be used to show leakages in main jets, idling needles, measuring cover gaskets and measuring diaphragms.

Leak in	Fault with
Diffuser jets Leak in the impulse pipe Ventilation hole on the metering unit.	Needle valve Pump membrane Control membrane



## Fitting the carburettor

1

Fit the carburettor.

2

Fit the pulse hose A, the input hose B, and the tank return hose C. See figure 44.

3

Fit the manifold. See figure 45.

4

Fit the choke and throttle rods to the carburettor. See figure 45B.

5

Fit the cylinder cover, air filter, air filter cover and the rear handle cover.

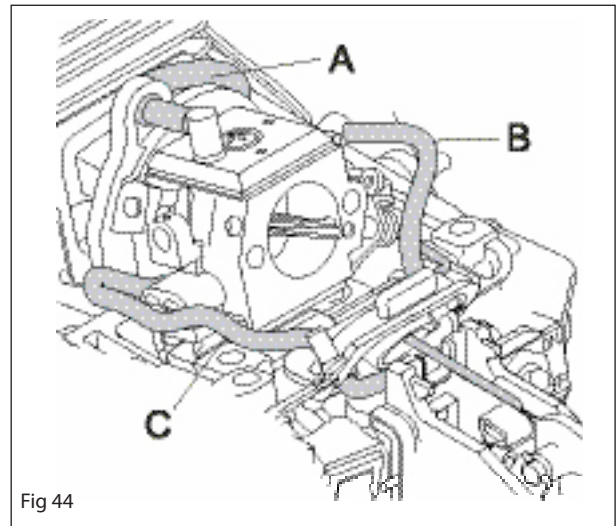

Fig 44

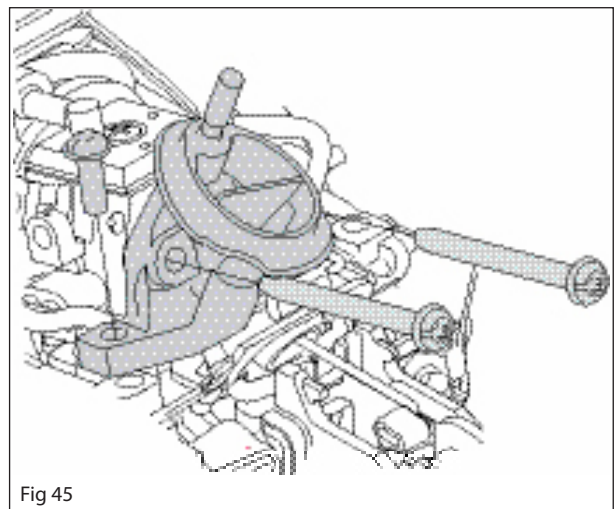

Fig 45

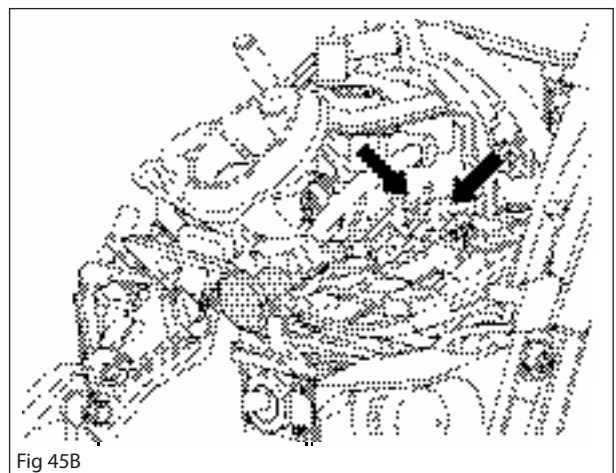

Fig 45B

## Adjustment



**WARNING!**  
The guide bar, saw chain and clutch cover must be fitted before the chain saw is started, otherwise the clutch may come loose causing personal injury.



**WARNING!**  
Wear ear defenders when making adjustments with the engine running.



**WARNING!**  
Do not use the chain saw until it has been adjusted so that the saw chain is still during idling.

### NOTE!

For optimal setting, a tachometer should be used. The recommended maximum overspeed should not be exceeded.

### NOTE!

If the saw chain turns when idling, the T-screw should be turned anti-clockwise until the saw chain stops.

Adjusting the carburettor involves adjusting the engine to the local conditions e.g. climate, altitude, fuel and type of 2-stroke oil.

The carburettor is equipped with three adjustment options:

- L = Low speed jet
- H = High speed jet
- T = Idling adjustment

The L- and H-jets adjust the fuel flow to match the airflow that the throttle valve opening allows. Turning them clockwise makes the fuel/air mixture weaker (less fuel) and turning them counter-clockwise makes the fuel/air mixture richer (more fuel). A weaker mixture increases the engine speed and a rich mixture decreases the engine speed.

The T- screw controls the throttle position when idling. Turning the T-screw clockwise gives faster idling, turning it counterclockwise gives lower idling speed.

Run the chain saw for approx. 10 minutes before adjusting the carburettor.

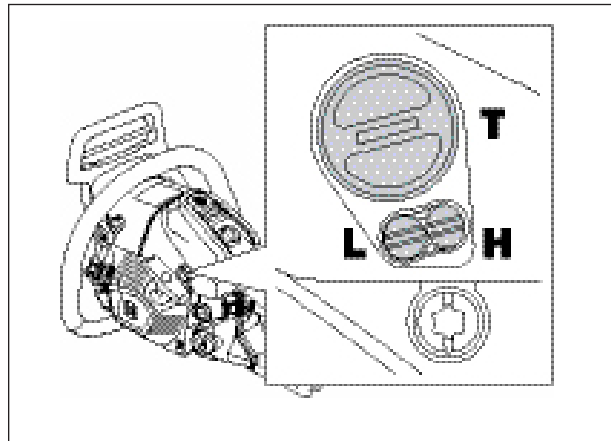

## Basic adjustment for chain saws with ignition system (IKEDA UK-09701) and carburetors without limiters (Walbro HD-54B)

To ensure that the engine components receive adequate lubrication (running in) the carburettor should be set to a somewhat richer fuel mixture for the chain saw's first 3-4 running hours. This is done by adjusting the maximum speed to 600-700 rpm less than the recommended maximum speed. Use tool 530 03 55-60 to adjust the carburettor (L- and H-needle).

Adjustment of the L-needle and T-needle.

1. Find the highest idling speed by slowly turning the L-screw clockwise and counterclockwise.
2. Turn the T-screw until the idling speed is 3 000 rpm.

3. Repeat the procedure in 1 and 2 once again.
4. Turn the L-screw counterclockwise 0,5 of a turn.
5. Adjust the T-screw until the idling speed is 2 700 rpm.

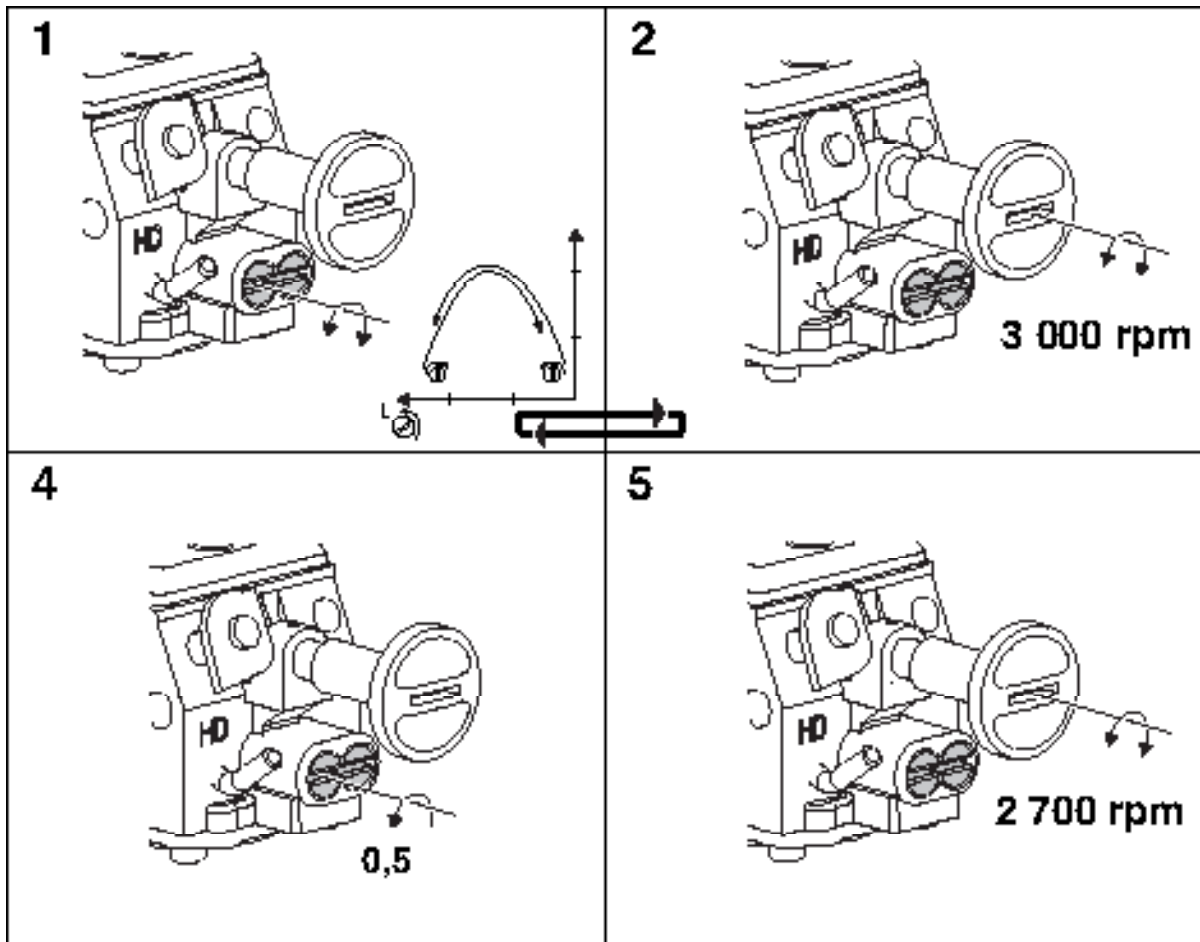

Adjustment of the H-needle.

1. Adjust the H-screw until the maximum engine speed at full throttle is 14 500 rpm.

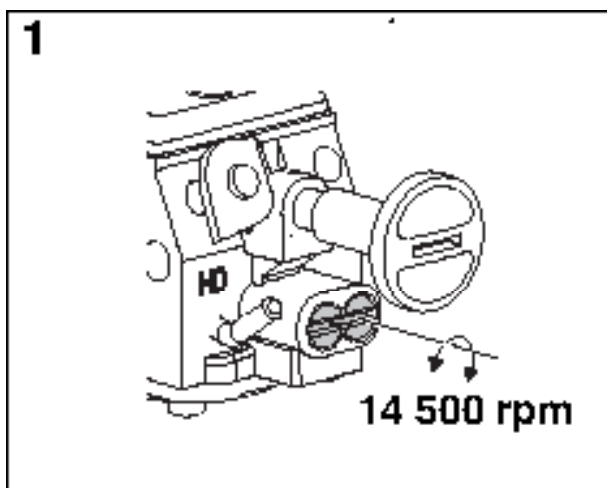

## 7.17 Tank unit



**WARNING!**

The fuel used in the chain saw has the following hazardous properties:

1. The fluid and its vapour are poisonous.
2. Can cause skin irritation.
3. Is highly inflammable.

### Dismantling

1. Drain the fuel from the tank.
2. Remove the clutch cover, saw chain, guide bar, starter and the cylinder cover. Remove the rear handle cover.
3. Detach hoses B and C. Detach the throttle rod A. See figure 46.
4. Remove the handle bar. Detach the handle heater. Remove the chain catcher.
5. Detach the cabling from the stop switch and earth cabling from the crankcase.
6. Detach the cabling from the handle heater switch and stop switch (top one)
7. Remove the tank unit. See figure 47.

### Assembly

1. Fit the tank unit. See figure 47.
2. Fit the earth cables.
3. Fit the stop control cable from the ignition module.
4. Fit the hoses B and C and the throttle rod A to the throttle trigger. See figure 46.
5. Fit the starter, cylinder cover, clutch cover, saw chain and the guide bar.

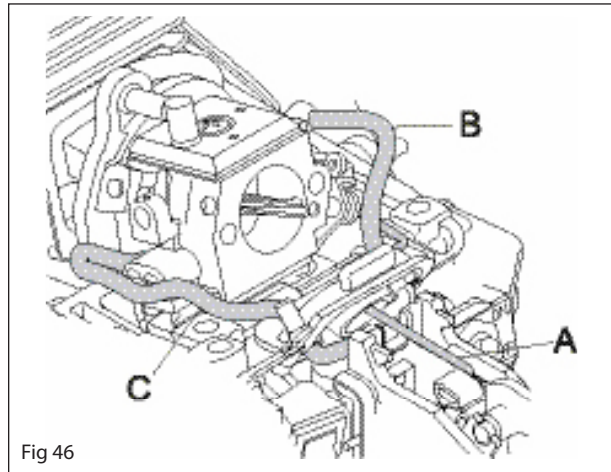

Fig 46

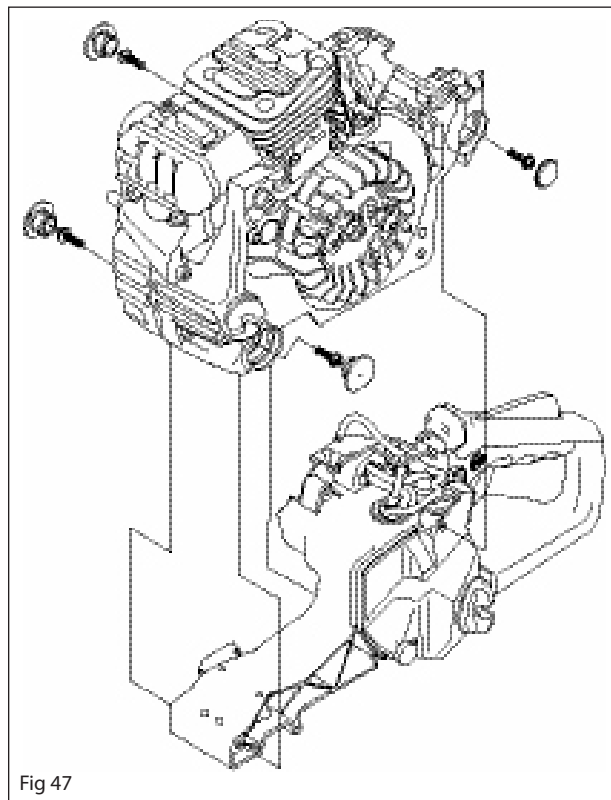

Fig 47

## 7.18 Vibration damping system

### Dismantling

Remove the plastic lids and rubber dampers on both sides. See figures 48-49.

### Cleaning and inspection

- Clean and inspect all parts carefully. If there are any cracks or other defects, replace the damaged parts with new ones. Always use original parts.

### Assembly

Fit the rubber dampers and plastic lids on both sides. See figures 48-49. Tightening torque 2,5 - 3,9 Nm

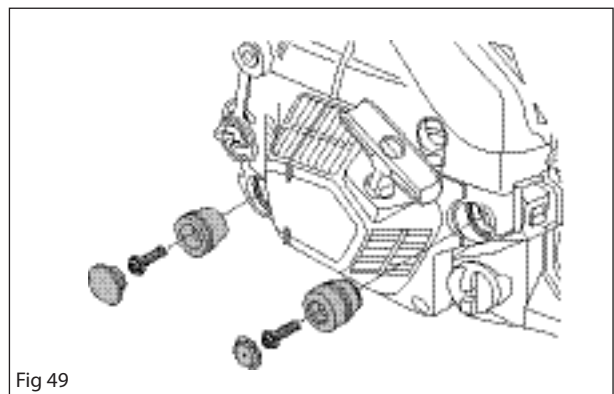
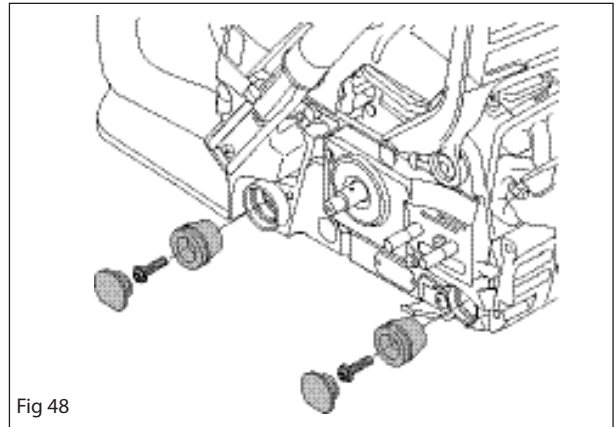

## 7.19 Replacing the fuel filter

**NOTE!**

Fluted pliers may not be used with the fuel hose. They can cause material damage resulting in damage to the fuel hose.

1  
When replacing the fuel filter, the old fuel filter must be taken out of the tank unit using special tool 502 50 83-01.

2  
Pull out the fuel hose from the tank unit and pull away the filter A. See figure 50.

3  
Fit the new fuel filter and insert the fuel hose back into the fuel tank.

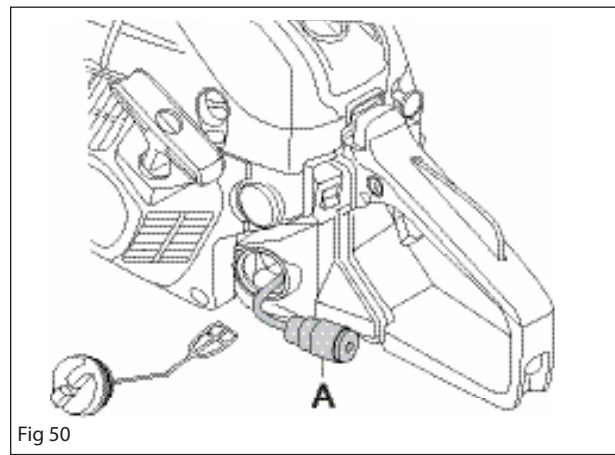

## 7.20 Replacing the primer bulb

Dismantle

1. Dismantle the cylinder cover and the air filter.
2. Loosen suction hose C and return hose from the primer bulb. See figure 51.
3. Snap off the fuel pump from the filter holder.

Assembling

1. Snap the primer bulb in place in the filter holder. See figure 51.
2. Fit the return and suction hose on the primer bulb.
3. Fit the air filter and cylinder cover.

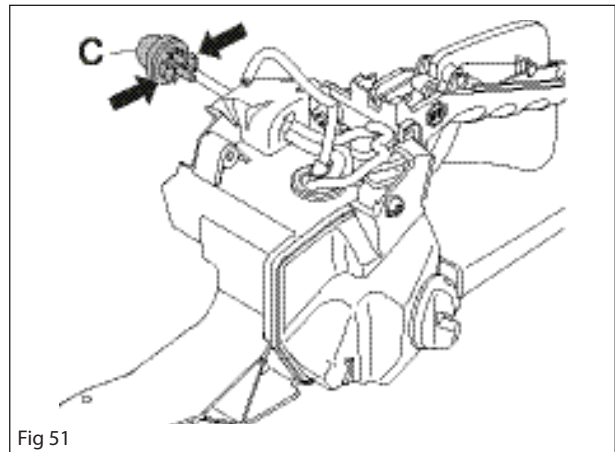

## 7.21 Replacing the fuel hose/return hose

The fuel hose is moulded and can only be removed from outside of the fuel tank.

Use suitable pliers with a smooth cutting face and loosen the hose B from the fuel tank. See figure 52.

Replace the return hose when required. Tighten the fuel hose on the filter side with your fingers.

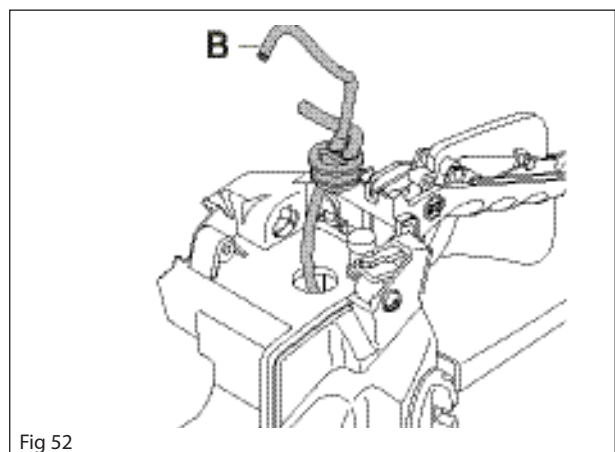

## 7.22 Handle heating system

The handle heating system comprises the following:

- Generator
- Power switch
- Heating elements in the rear handle and the front handle bar.

### Troubleshooting

Troubleshooting requires:

- Ammeter
- Ohmmeter
- Coolant

Oxidation of the connectors in the heating elements in the rear handle and the power switch's contact plate is the most common fault.

Troubleshoot as follows:

1

Remove the screw holding the earth cables. Remove the cover. See Figure 53.

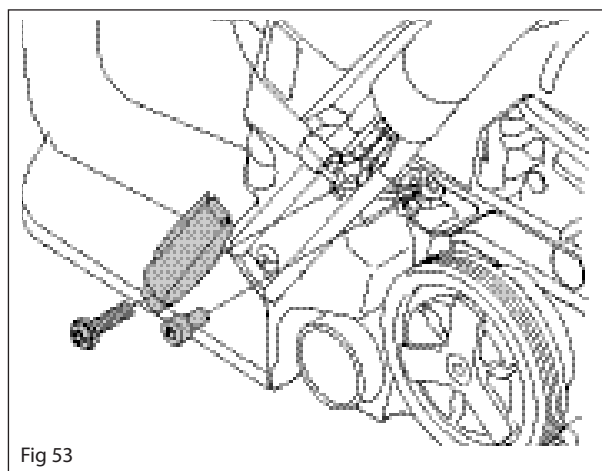

Fig 53

2

Measure the resistance in the whole circuit by connecting the multimeter to the earth cable and a properly cleaned cylinder. See Figure 54.

A correct reading with the power switch set to "OFF" =  $\infty \Omega$ .

A correct reading with the power switch set to "ON" =  $3.1 \Omega$  to  $4.1 \Omega$ .

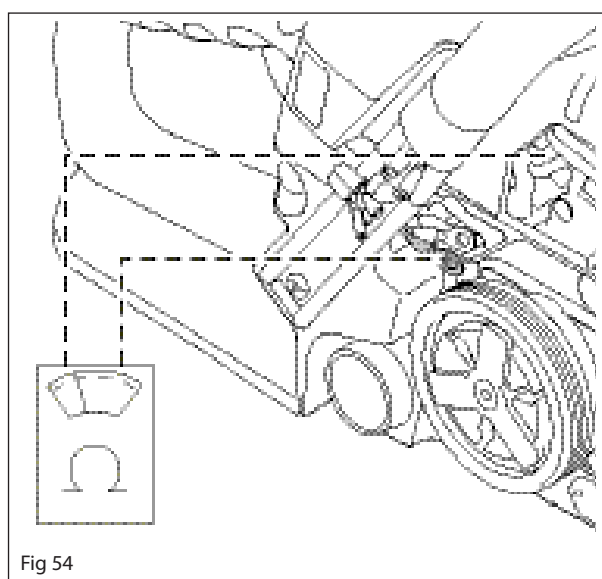

Fig 54

Troubleshooting the heating element, rear handle

1  
Connect the multimeter as outlined in Figure 55 and measure the resistance in the rear handle's heating element.

2  
The multimeter reading should indicate between  $0.4 \Omega$  and  $0.6 \Omega$ . Replace the heating element if you get another reading.

- Check the heating element for cracks or thermal deformation. If necessary, replace it with a new one.
- If the lead wires covering material is damaged or worn, replace it with a new one.

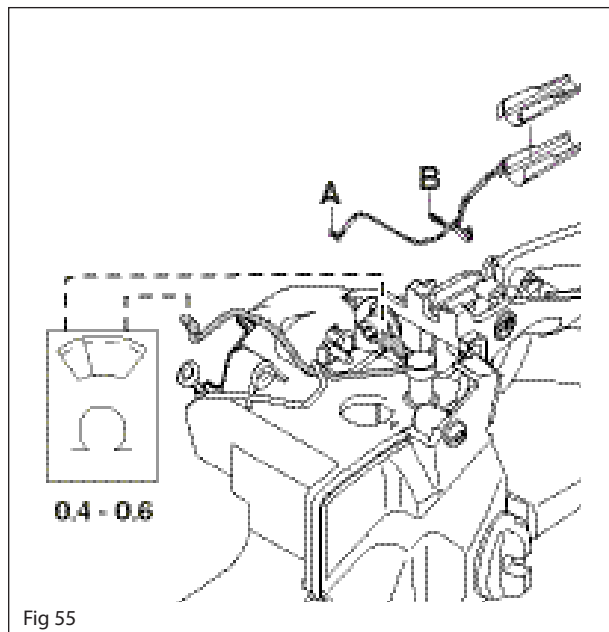

Fig 55

Troubleshooting the heating element, front handle

1  
Connect the multimeter as outlined in Figure 56 and measure the resistance in the front handle's heating element.

2  
The multimeter reading should indicate between  $1.8 \Omega$  and  $2.4 \Omega$ . Replace the front handle if you get another reading.

- If the lead wire is open-circuted or its covering material is worn or damaged, replace it with a new one.

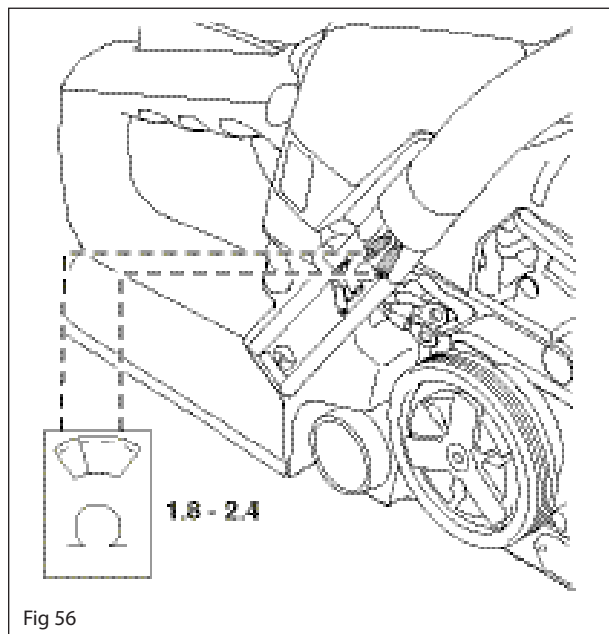

Fig 56

Troubleshooting the generator

1  
Connect the multimeter to the generator cable and the heater coil as outlined in Figure 57.

2  
The multimeter reading should indicate between  $0.9 \Omega$  and  $1.1 \Omega$ . Replace the generator if you get another reading.

- Check for cracks and thermal deformation. If necessary, replace with a new one.
- If the lead wire is damaged, replace with a new one.

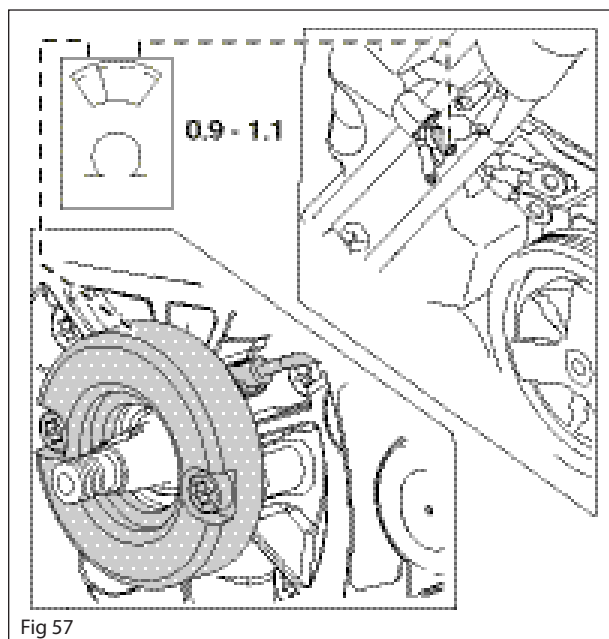

Fig 57



When replacing the generator, use special tool 512 41 31-01 to fix the heating coil. Also, apply three bond #1322 (thread lock) or similar to the screws. See figure 57B. Tightening torque 2,9 - 3,9 Nm.

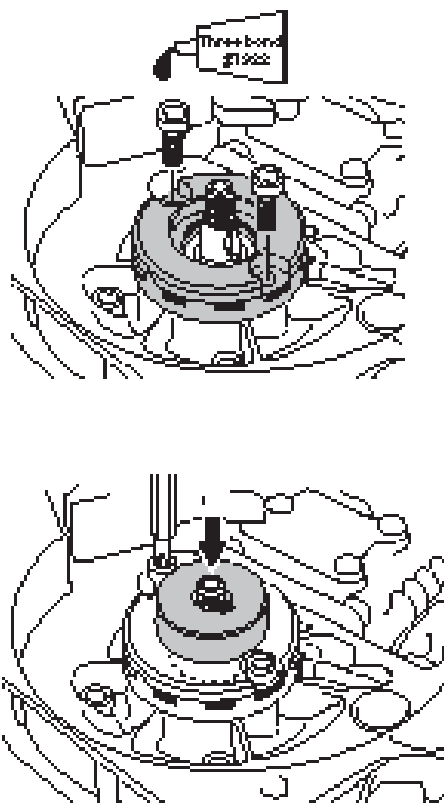

Fig 57B

### 7.23 Dismantling the piston and cylinder

1

Dismantle the:

- cylinder cover
- front handle
- carburettor
- muffler
- spark plug cap
- intake system

2

Remove the cylinder's four screws. Carefully lift away the cylinder and the gasket. See figure 58.

#### NOTE!

Take care to prevent any dirt and foreign particles from entering the crankcase.

3

Cover the crankcase opening.

4

Remove the circlips and press out the gudgeon pin. Remove the piston. See figure 59.

5

Remove the gudgeon pin bearing (the needle bearing) using a pliers. See figure 59.

6

Replace with a new bearing.

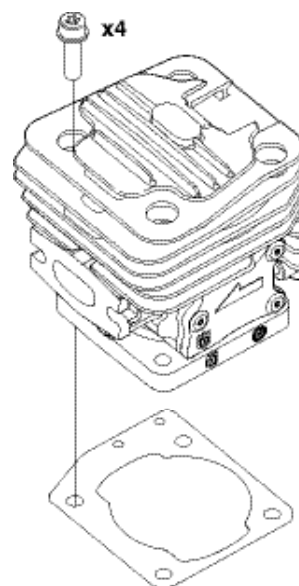

Fig 58

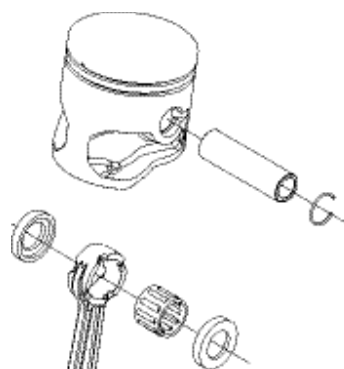

Fig 59

Cleaning and inspection of the cylinder

Clean all components, scrape off all gasket remains and soot from the following areas:

- Piston crown
- Top of the cylinder bore (inside)
- Cylinder exhaust port
- Base of the cylinder and/or crankcase

Check the following:

- That the cylinder's surface coating is not worn. Especially the upper part of the cylinder.
- That the cylinder does not have any chafe or cutting marks. See figure 60.
- That the piston is free of score marks. Minor scratches can be polished off using fine emery paper.
- That the piston ring is not burnt into its groove.
- Measure the wear on the piston rings. This must not exceed 1 mm. See figure 61. Use the piston to push the piston ring downward.
- That the gudgeon pin bearing is intact.
- That the intake bellows is intact.

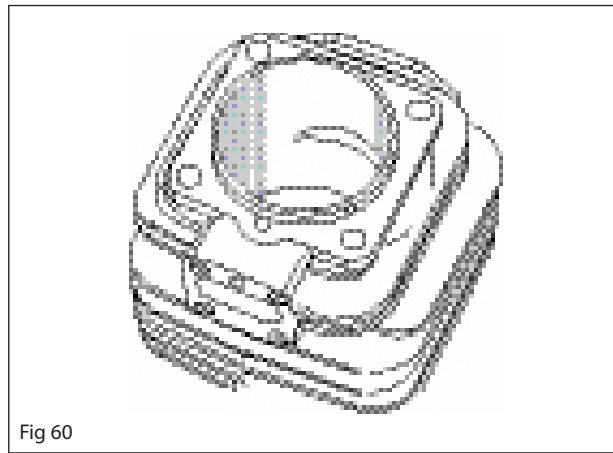

Fig 60

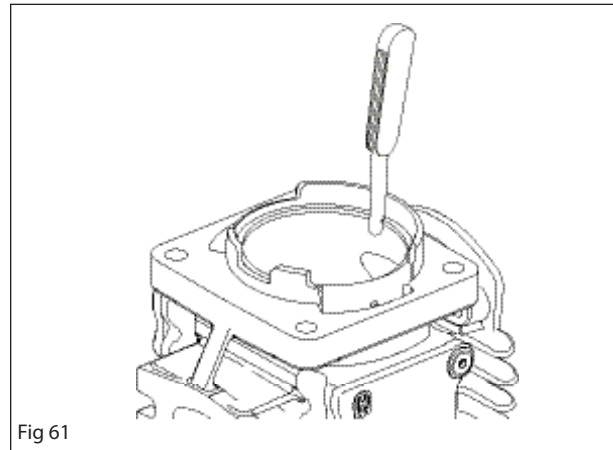

Fig 61

Faults and causes

See Figure 62.

Score marks on the piston (A)

- 1 Leakage, check not carried out.
- 2 Too low octane fuel.
- 3 Too low or incorrect oil in the fuel.

Carbon build-up (B)

- 1 Too much or incorrect oil in the fuel.

Piston ring breakage

- 1 Piston ring worn out.
- 2 Oversized piston ring groove.

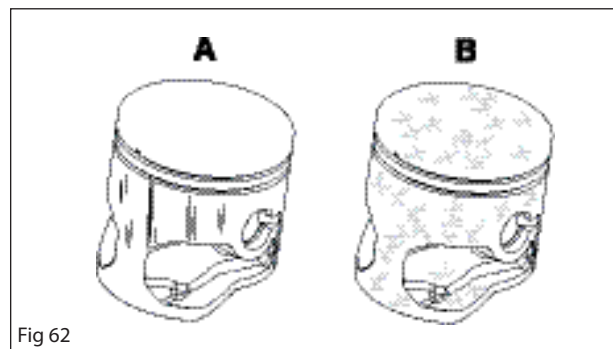

Fig 62

## 7.24 Assembling the piston and cylinder

1

Oil the gudgeon pin bearing with two-stroke oil and insert the crank rod. See figure 63.

2

Attach the piston with the arrow facing the exhaust port. Slide in the gudgeon pin and fit the circlips. Note! Use new circlips.

3

Oil the piston with two-stroke oil.

4

Use piston assembly kit 502 50 70-01 when mounting the cylinder. See figure 64.

5

Tighten the cylinder screws crosswise. Tightening torque 6,9 - 8,8 Nm.

6

Assemble the:

- intake system \*
- spark plug cap \*
- muffler \*
- carburettor \*
- front handle \*
- cylinder cover \*

\* See specific instruction.

### NOTE!

It is very important that the intake system is sealed. Otherwise the engine may seize up.

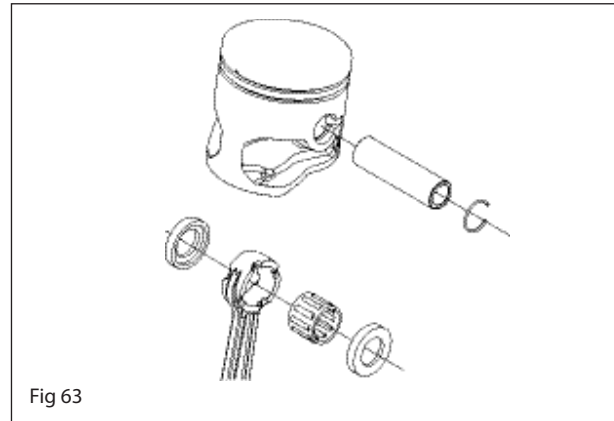

Fig 63

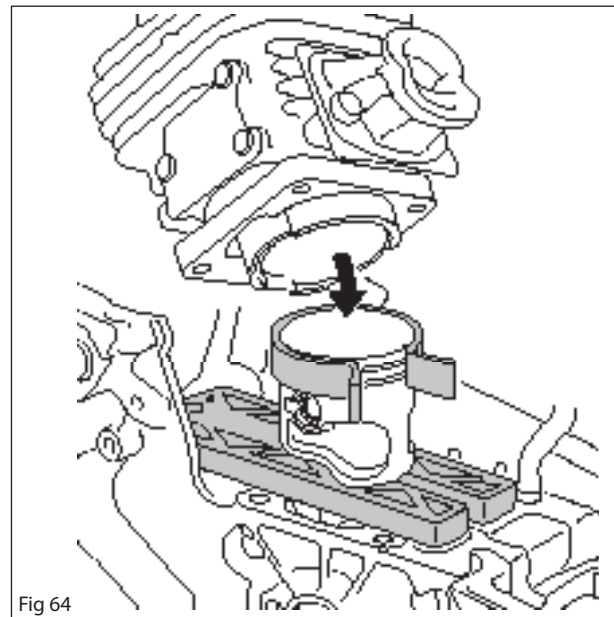

Fig 64

## 7.25 Leakage testing

1

Remove the:

- cylinder cover
- carburettor
- spark plug

2

Attach the cover plate 574 71 14-01 and plug 503 84 40-03. See figure 65.

3

Loosen the screws on the muffler and press the cover plate 502 54 11-02 between the muffler and cylinder (remove the muffler gasket). Tighten the nuts for the muffler. See figure 66.

4

Screw the pressure test connection 503 84 40-03 in place. Connect tool 531 03 06-23 to the nipple. See figure 67.

5

Pump the pressure up to 80 kPa (0.8 bar). Wait 30 seconds. The pressure should not be less than 60 kPa (0.6 bar). Remove the cover plates from the muffler and carburettor, tighten the bolts to the specified torque. Remove the pressure test nipple and refit the spark plug.

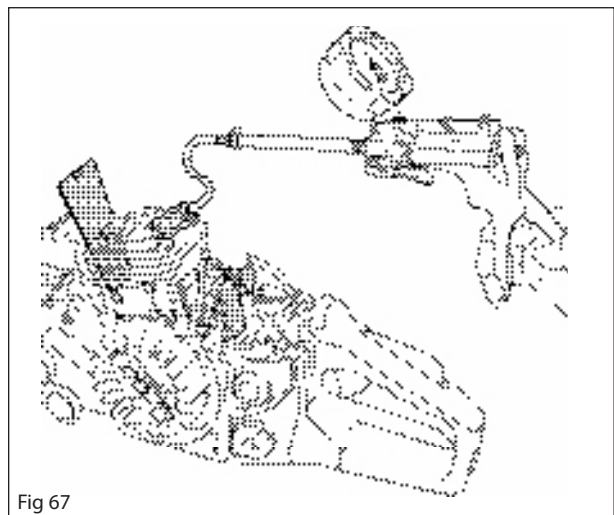
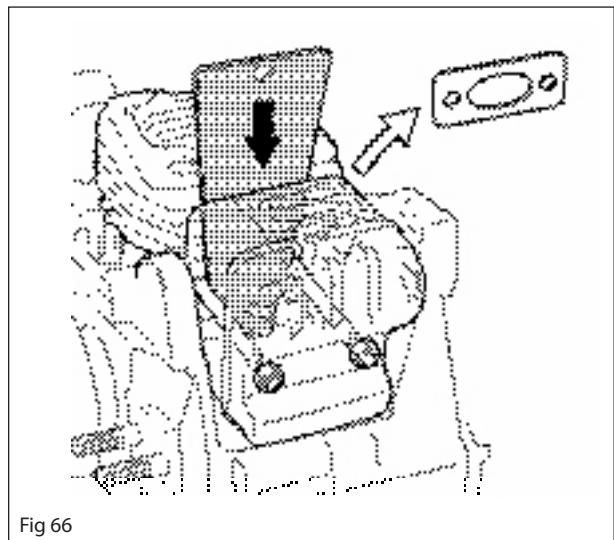
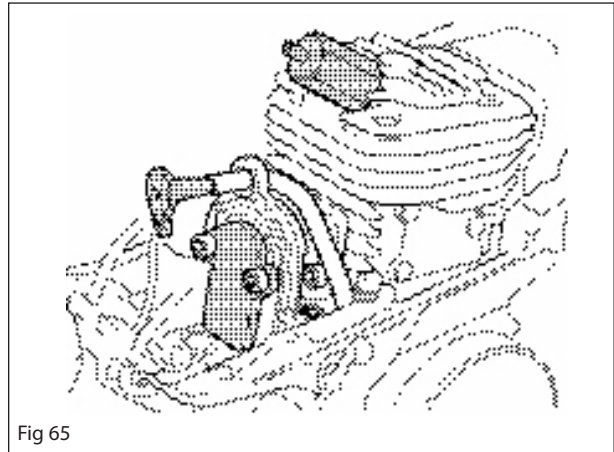

## Cylinder compression test

1

Remove the spark plug and fit the pressure test tool art.nr 531 03 16-86. Use the 10mm adapter 583 84 98-01.

2

Pull the starter handle to measure the compression in the cylinder. The compression should not be under 686 kPa (7Kg/cm<sup>2</sup>). See figure 67B.

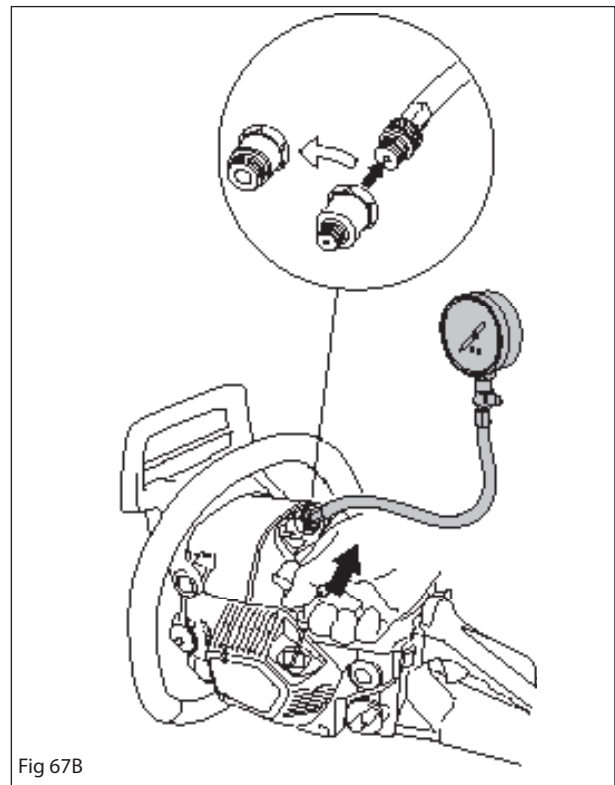

Fig 67B

## 7.26 Dismantling the crankshaft and crankcase

1

Dismantle the following:

- Clutch cover
- Saw chain and guide bar
- Centrifugal clutch \*
- Cylinder cover \*
- Starter \*
- Flywheel \*
- Carburettor \*
- Hand guard \*
- Muffler \*
- Fuel unit \*
- Piston and cylinder \*
- Ignition module \*
- Cabling \*
- Oil pump \*

\* See specific instruction.

2

Remove the 5 screws from the pulley wheel side. See Figure 68.

3

Carefully pull the crankcase halves apart. Two guide pins keep the crankcase halves together. Remove the connecting rod and dispose of the gasket.

4

If required, remove the crankshaft bearings and sealing rings from the crankcase.

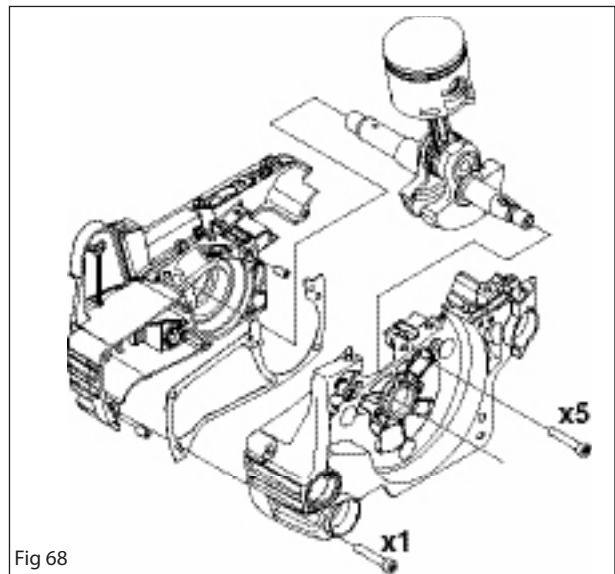

Fig 68

Cleaning and inspection

**NOTE!**

If the bearings are fitted to the crankcase, take care to prevent any dirt and foreign particles from entering.

Clean all parts and scrape off all gasket remains from the contact surfaces on the crankcase halves.

Check the following:

1. That the big-end bearing does not have any radial play. Axial play is permitted. See figures 69.
2. That the big-end bearing does not have any score marks or is discoloured on the sides.
3. That the bearing surface for the gudgeon pin bearing does not have any score marks or is discoloured. See figure 70.
4. That the crankshaft bearing has no play or knocks.
5. That the sealing surfaces of the sealing rings fitted against the crankshaft are not worn, and that the rubber is not hard.
6. That the crankcase is not cracked.
7. Also inspect the bearing grip in the crankcase half.

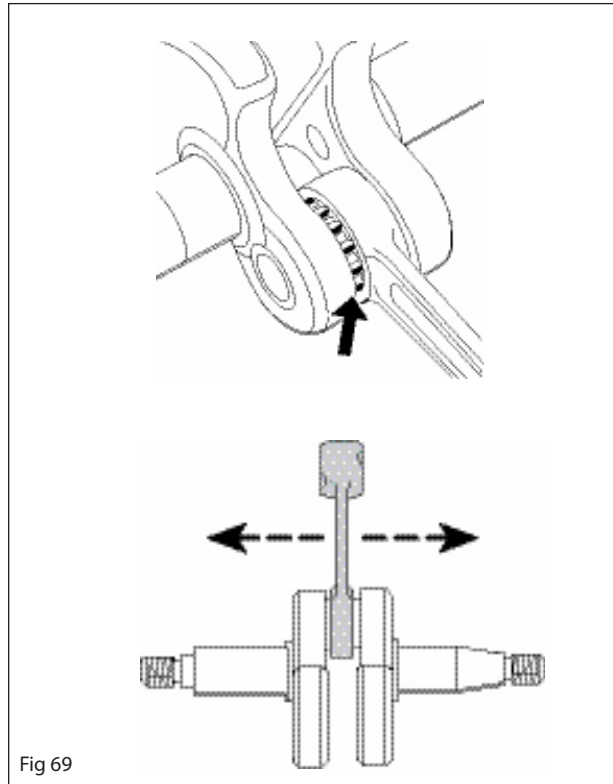

Fig 69

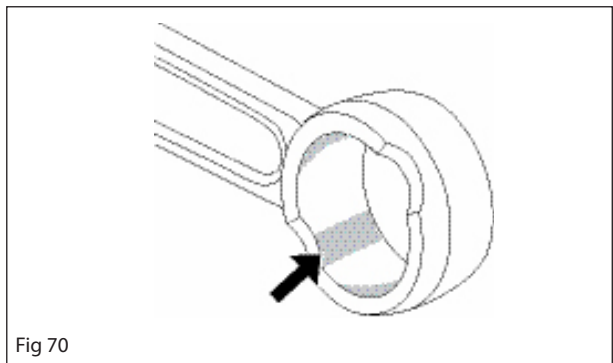

Fig 70

## Assembly: bearings &amp; oil seals

**NOTE!**

Take care to prevent any dirt and foreign particles from entering the bearings.

Proceed as follows if new bearings and oil seals must be fitted:

- 1  
Fit the bearing in the flywheel side of the crankcase half. Make sure the bearing is fitted aligned with the inside of the crankcase. Drive the bearing lightly into the crankcase with a plastic hammer. See figure 71.
- 2  
Use special tool 584 14 05-01 as outlined in figure 72 to press the bearing into the crankcase.
- 3  
Use the same procedure for the press-fitting of the bearing on the clutch side. Note! Use special tool 584 14 05-02 in this case.
- 4  
Apply grease to the sealing surfaces. Press-fit the oil seals as outlined in figure 73. Special tool used: 584 14 05-01 (MAG side), 584 14 05-02 (PTO side).

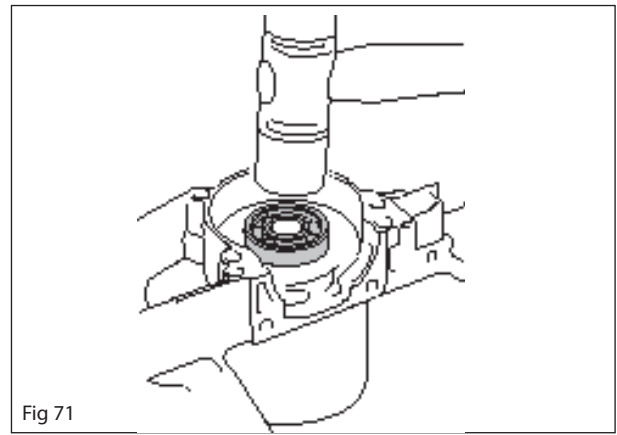

Fig 71

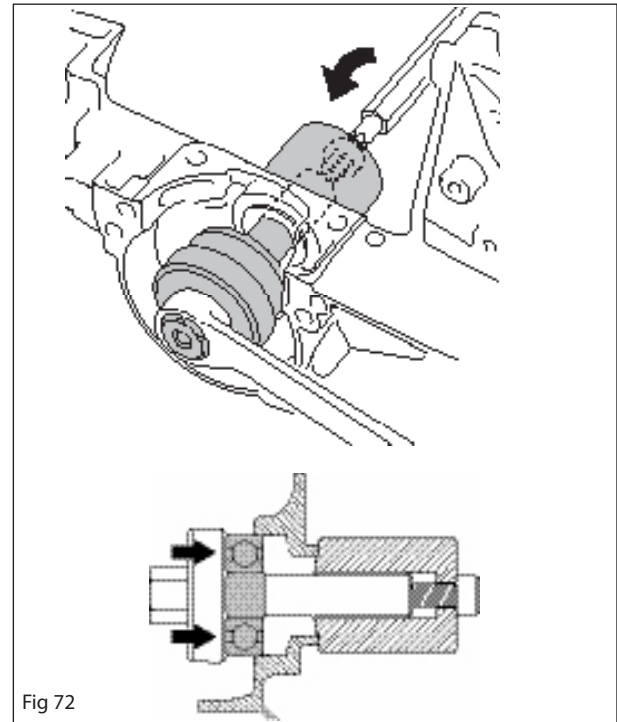

Fig 72

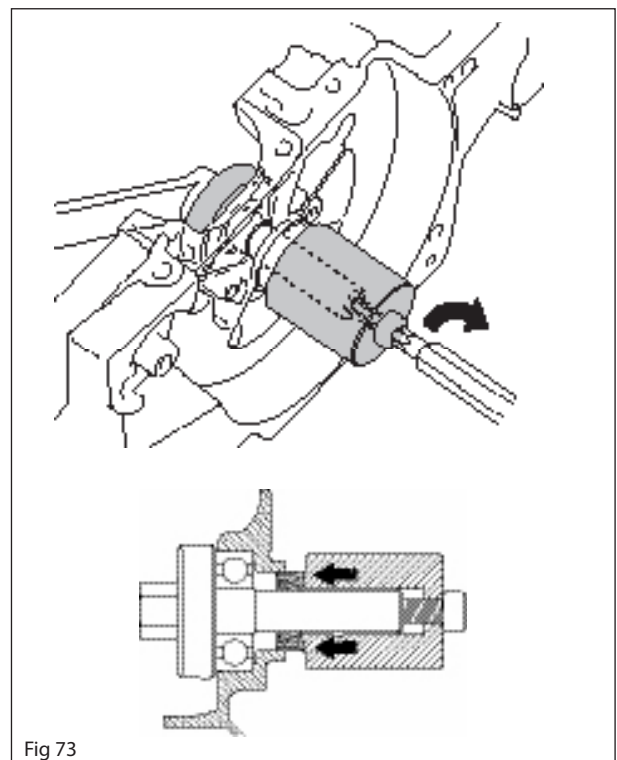

Fig 73

8

Fit the crankshaft to the PTO side of the crankcase. Note! Fit the guide, 513 70 59-01, to the crankshaft journal before the crankshaft is inserted. The guide prevents the oil seal from getting damaged. Remove the guide afterwards. See figure 74

9

Place the guide pegs in the PTO side half. Grease in and fit a new gasket. See figure 75.

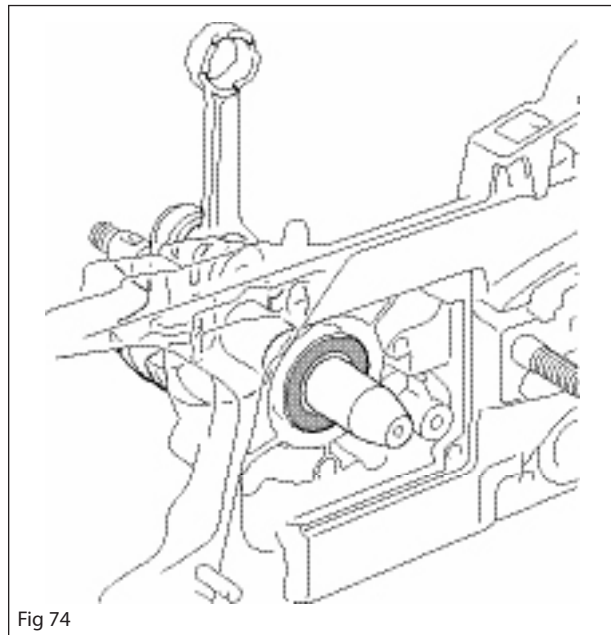

Fig 74

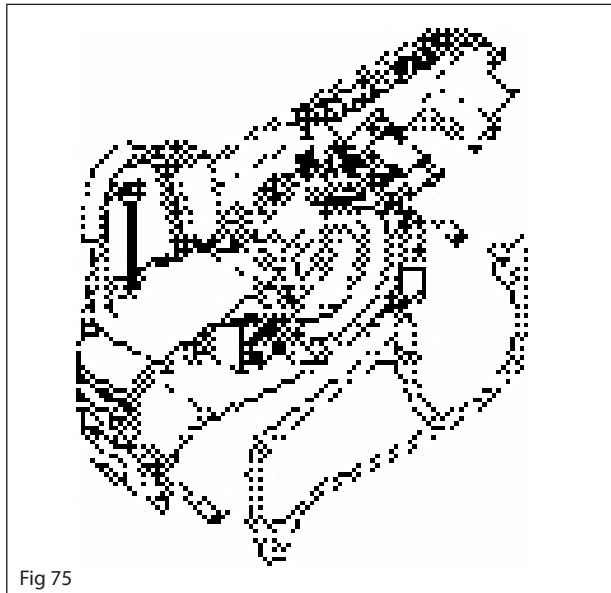

Fig 75



10

Fit the piston assembly tool (against rotation). Use the crankshaft assembly tool 502 50 30-22 and pull the crankshaft into the MAG side of the crankcase. See figure 76.

11

Fix the six crankcase bolts. Tighten them alternately. Tightening torque 6,9 - 8,8 Nm. See figure 77.

12

Refit remaining parts.

**NOTE!**

Take care to prevent any dirt and foreign particles from entering the crankcase.

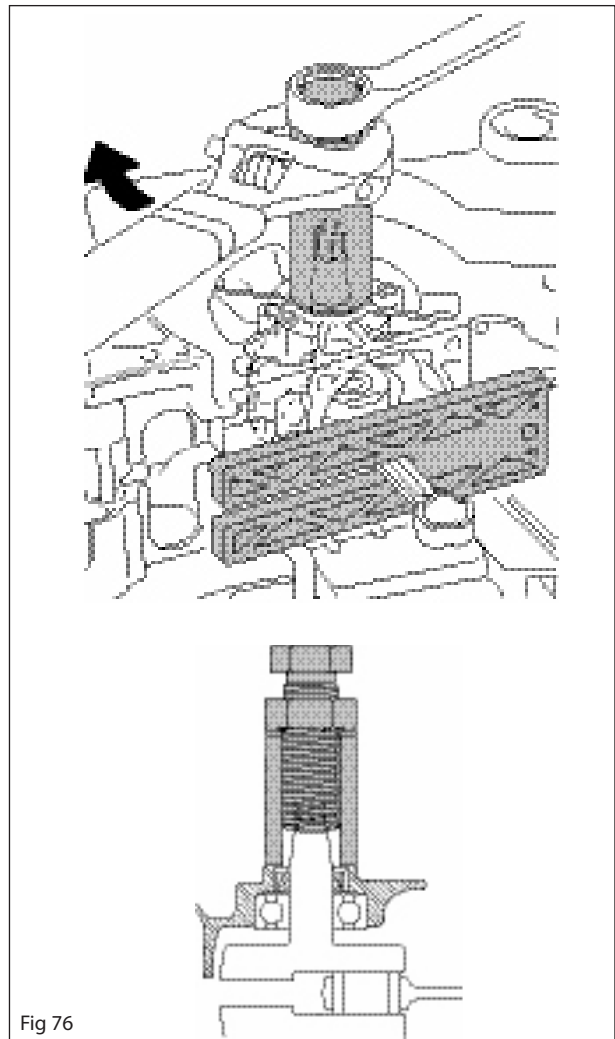

Fig 76

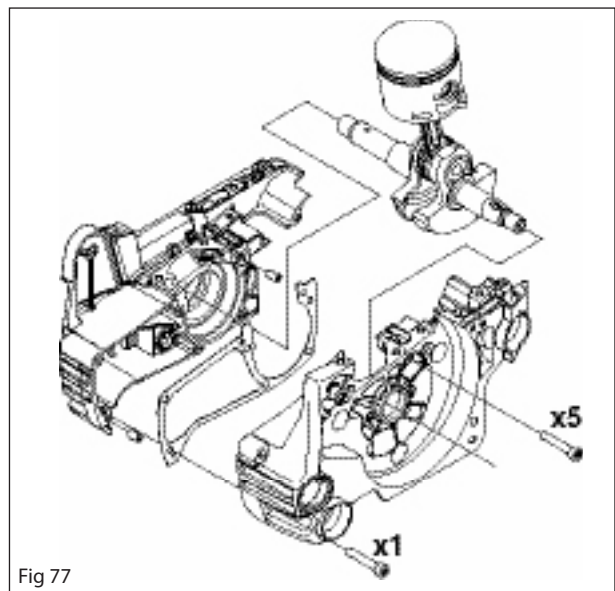

Fig 77

# 8 Troubleshooting

## Contents

8.1	Troubleshooting .....	58
8.2	Troubleshooting methods .....	59

## 8.1 Troubleshooting

The various faults that can affect a chain saw are divided into four groups. In each group the likely symptoms are given on the left and possible causes are listed on the right. The most likely faults are given first, and so on.

### Starting

Difficulty starting	Adjust L screw Air filter blocked Choke not working Worn choke pivot Worn choke valve Fuel filter blocked Fuel line blocked Piston ring seized Blocked impulse channel
Carburettor leaking fuel	Loose or faulty fuel pipe Hole in diaphragm Worn needle valve Needle valve assembly sticking Needle valve set too high Leak in metering system (air or fuel) Loose cover on carburettor pump side
Flooding when engine not running	Worn needle valve Needle valve set too high Needle valve assembly sticking

### Idling (low rpm)

Will not idle	Adjust L screw Leaking air intake hose (rubber) Loose carburettor mounting bolts Loose or faulty fuel hose Fuel filter blocked Fuel line blocked Fuel tank vent blocked Throttle valve pivot stiff Throttle pushrod sticking Defective throttle return spring Bent throttle stop Faulty diffuser jet
Idling too rich	Adjust L screw Worn needle valve Needle valve set too high Worn needle valve lever Leaking control diaphragm/cover plate Needle valve assembly sticking

### Idling (low rpm) (cont.)

Idles when L screw closed	Worn needle valve Leaking control diaphragm/cover plate Needle valve assembly sticking Worn needle valve lever Faulty diffuser jet
Idling uneven	Fuel filter blocked Fuel line blocked Leaking air intake hose (rubber) Loose carburettor mounting bolts Worn throttle valve pivot Loose throttle valve screw Worn throttle valve Needle valve assembly sticking Leak in metering system (air or fuel) Metering system centre knob is worn Hole in diaphragm Leaking control diaphragm/cover plate Crankcase leaking
L screw requires constant adjustment	Fuel line blocked Needle valve set too high Needle valve assembly sticking Leak in metering system (air or fuel) Leaking control diaphragm/cover plate Faulty diffuser jets Crankcase leaking
Too much fuel at idling	Needle valve set too high Needle valve assembly sticking Metering system damaged Worn needle valve Leaking control diaphragm/cover plate Metering system incorrectly assembled

High rpm

Will not run at full throttle	Adjust H screw Blocked air filter Blocked fuel tank vent Blocked fuel filter Fuel line blocked Loose or damaged fuel hose Impulse channel leaking Impulse channel blocked Loose cover on carburettor pump side Faulty pump diaphragm Leaking air intake hose (rubber) Loose carburettor mounting bolts Needle valve set too low Metering system damaged Metering system incorrectly assembled Leaking control diaphragm/cover plate Needle valve assembly sticking Blocked silencer
Low power	Adjust H screw Blocked fuel tank vent Blocked fuel filter Impulse channel leaking Impulse channel blocked Loose cover on carburettor pump side Faulty pump diaphragm Blocked air filter Needle valve assembly sticking Leak in metering system (air or fuel) Metering system incorrectly assembled Loose diaphragm rivet Hole in diaphragm Leaking control diaphragm/cover plate
Will not "four-stroke"	Blocked fuel tank vent Blocked fuel filter Fuel line blocked Loose or damaged fuel hose Impulse channel leaking Impulse channel blocked Loose cover on carburettor pump side Faulty pump diaphragm Leaking air intake hose (rubber) Loose carburettor mounting bolts Needle valve set too low Leak in metering system (air or fuel) Metering unit incorrectly assembled Loose diaphragm rivet Hole in diaphragm Leaking control diaphragm/cover plate

Acceleration och retardation

Does not accelerate	Adjust L screw Adjust H screw Blocked air filter Blocked fuel tank vent Blocked fuel filter Fuel line blocked Loose or damaged fuel hose Impulse channel blocked Loose cover on carburettor pump side Faulty pump diaphragm Leaking air intake hose (rubber) Loose carburettor mounting bolts Needle valve set too low Metering system incorrectly assembled Needle valve assembly sticking Faulty diffuser jets Blocked silencer
Engine stalls when throttle released	Adjust L screw Adjust H screw Faulty pump diaphragm Needle valve set too high Needle valve assembly sticking Faulty diffuser jets
Over rich acceleration	Adjust L screw Adjust H screw Blocked air filter Faulty pump diaphragm Faulty diffuser jets

8.2 Troubleshooting methods

In addition to the faults described in the above table, trouble shooting can be carried out on specific components or sub-systems of the chain saw. The various procedures are described in the relevant chapters, see the contents page, as follows:

- Checking the operation of the chain brake
- Measuring the resistance of the stop plate
- Pressure testing the carburettor
- Pressure testing the decompression valve
- Pressure testing the cylinder





[www.zenoah.com](http://www.zenoah.com)