

**STIHL MS 440**

2006-05

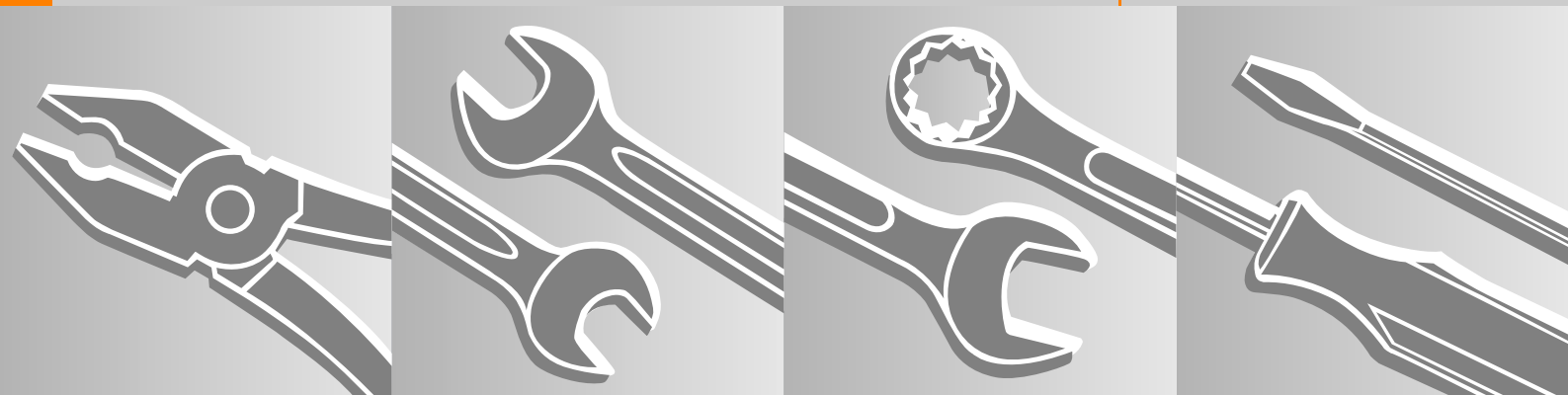

## Contents

<b>1.</b>	<b>Introduction</b>	<b>3</b>	<b>6.</b>	<b>Engine</b>	<b>24</b>	<b>9.</b>	<b>AV handle system</b>	<b>59</b>
<b>2.</b>	<b>Safety Precautions</b>	<b>4</b>	6.1	Muffler / Spark Arresting Screen	24	<b>10.</b>	<b>Single lever master control / handle system</b>	<b>60</b>
<b>3.</b>	<b>Specifications</b>	<b>5</b>	6.2	Leakage Test	25	10.1	Switch shaft	60
3.1	Engine	5	6.2.1	Preparations	26	10.2	Throttle Trigger / Interlock Lever	61
3.2	Fuel System	5	6.2.2	Pressure Test	27	<b>11.</b>	<b>Chain Lubrication</b>	<b>62</b>
3.3	Ignition System	5	6.2.3	Vacuum Test	27	11.1	Pickup Body / Suction Hose	62
3.4	Chain Lubrication	5	6.3	Oil Seals	28	11.2	Valve	63
3.5	Tightening Torques	6	6.4	Removing the shroud	30	11.2.1	Cleaning	63
<b>4.</b>	<b>Troubleshooting Chart</b>	<b>7</b>	6.5	Cylinder and Piston	30	11.2.2	Replacing	63
4.1	Clutch, Chain Drive, Chain Brake, Chain Tensioner	7	6.5.1	Removing	30	11.3	Oil pump	64
4.2	Rewind Starter	8	6.5.2	Installing	32	11.3.1	Removing and installing	64
4.3	Chain Lubrication	9	6.6	Piston Rings	35	11.3.2	Servicing	64
4.4	Ignition System	10	6.7	Crankcase	35	<b>12.</b>	<b>Fuel System</b>	<b>65</b>
4.5	Carburetor	11	6.7.1	Removing the crankshaft	35	12.1	Air Filter	65
4.6	Engine	13	6.7.2	Installing the crankshaft	38	12.2	Carburetor	66
<b>5.</b>	<b>Clutch, Chain Drive, Chain Brake and Chain Tensioner</b>	<b>14</b>	6.8	Decompression Valve	43	12.2.1	Removing and Installing	66
5.1	Clutch Drum / Chain Sprocket	14	<b>7.</b>	<b>Ignition System</b>	<b>44</b>	12.2.2	Leakage Test	68
5.2	Replacing the Chain Catcher	15	7.1	Ignition Module	44	12.3	Servicing the Carburetor	68
5.3	Clutch	15	7.1.1	Ignition Timing	44	12.3.1	Metering Diaphragm	68
5.4	Chain brake	17	7.1.2	Removing and Installing	45	12.3.2	Inlet Needle	69
5.4.1	Checking correct operation	17	7.1.3	Testing the ignition system	46	12.3.3	Fixed Jet	70
5.4.2	Removing	18	7.2	Ignition Lead / Spark Plug Boot	47	12.3.4	Pump Diaphragm	70
5.4.3	Installing	20	7.3	Flywheel	48	12.4	Adjustment (carburetor without limiter caps)	71
5.5	Chain Tensioner	22	7.3.1	Removal	48	12.4.1	Adjustment (carburetor with limiter cap)	72
5.6	Bar Mounting Studs	23	7.3.2	Installation	49	12.4.2	Basic Setting (carburetor with limiter cap)	73
			7.4	Stop switch	49	12.5	Tank Vent	74
			7.5	Wiring harness	49	12.6	Pickup Body	74
			7.5.1	Testing Wiring Harness	50	12.7	Fuel Hose	75
			7.6	Ignition System Troubleshooting	51	12.8	Tank housing	76
			<b>8.</b>	<b>Rewind Starter</b>	<b>54</b>			
			8.1	General	54			
			8.2	Removing and Installing	54			
			8.3	Pawls	54			
			8.4	Rope Rotor	55			
			8.5	Starter rope	55			
			8.5.1	Tensioning	56			
			8.6	Starter Rope Guide Bushing	57			
			8.7	Replacing the Rewind Spring	58			

**STIHL**<sup>®</sup>

© ANDREAS STIHL AG & Co. KG, 2006

## Contents

<b>13.</b>	<b>Carburetor Heating</b>	<b>79</b>
13.1	Troubleshooting Chart	80
13.2	Heating element with thermostatic switch	81
<b>14.</b>	<b>Handle Heating System</b>	<b>81</b>
14.1	Troubleshooting	81
14.1.1	Troubleshooting Chart	83
14.1.2	Test Connections and Test Values	85
14.2	Heater switch	86
14.3	Heating element in front handle	86
14.4	Heating element in front handle	87
14.5	Generator	88
<b>15.</b>	<b>Special Servicing Tools</b>	<b>89</b>
<b>16.</b>	<b>Servicing Aids</b>	<b>91</b>

## 1. Introduction

This service manual contains detailed descriptions of all the typical repair and servicing procedures for this power tool.

You should make use of the illustrated parts lists while carrying out repair work. They show the installed positions of the individual components and assemblies.

Refer to the latest edition of the relevant parts list to check the part numbers of any replacement parts.

A fault on the machine may have several causes. To help locate the fault, consult the chapter on "Troubleshooting" and the "STIHL Service Training System".

Refer to the "Technical Information" bulletins for engineering changes which have been introduced since publication of this service manual. Technical information bulletins also supplement the parts list until an updated edition is issued.

The special tools mentioned in the descriptions are listed in chapter "Special Servicing Tools" of this manual. Use the part numbers to identify the tools in the "STIHL Special Tools" manual which lists all the special servicing tools currently available from STIHL.

Symbols are included in the text and pictures for greater clarity. The meanings are as follows:

In the descriptions:

- = Action to be taken as shown in the illustration (above the text)
- = Action to be taken that is not shown in the illustration (above the text)
- ➡ = Situation applies as from serial No.
- ➡ = Situation applies up to serial No.

In the illustrations:

- ➡ Pointer
- ➡ Direction of movement
- 📖 4.2  
Reference to another chapter, i.e. chapter 4.2 in this example.

Service manuals and technical information bulletins are intended exclusively for the use of properly equipped repair shops. They must not be passed to third parties.

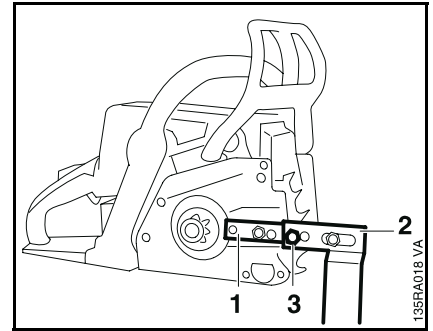

Servicing and repairs are made considerably easier if the clamp (1) 5910 890 2000 is used to mount the machine on assembly stand (2) 5910 890 3100 so that one clamp screw engages the outer 10 mm (0.39 in) hole (3) in the assembly stand.

To service the underside of the machine (e.g. remove the front handle), turn it upside down and mount it so that one clamp screw engages the inner 10 mm (0.39 in) hole in the assembly stand.

Pull the hand guard back against the front handle for this purpose.

### Always use original STIHL replacement parts.

They can be identified by the STIHL part number, the **STIHL** logo and the STIHL parts symbol . This symbol may appear alone on small parts.

## 2. Safety Precautions

If the engine is started up in the course of repairs or maintenance work, observe all local and country-specific safety regulations as well as the safety precautions and warnings in the instruction manual.

Gasoline is an extremely flammable fuel and can be explosive in certain conditions.

Improper handling may result in burns or other serious injuries.

### **Warning!**

Do not bring any fire, flame, spark or other source of heat near the fuel. All work with fuel must be performed outdoors only. Spilled fuel must be wiped away immediately.

### 3. Specifications

#### 3.1 Engine

Displacement:	70.7 cm <sup>3</sup> (4.31 cu.in)
Bore:	50 mm (1.97 in)
Stroke:	36 mm (1.42 in)
Engine power to ISO 7293:	4 kW (5.4 bhp) at 9,500 rpm
Max. permissible engine speed with bar and chain:	13,500 ± 150 rpm
Idle speed:	2,500 1 rpm
Clutch:	Centrifugal clutch with three unlined clutch shoes
Clutch engages at:	3,500 rpm
Crankcase leakage test at gauge pressure:	$p_{\bar{u}} = 0.5 \text{ bar (7.25 psi)}$
under vacuum:	$p_{\bar{u}} = 0.5 \text{ bar (7.25 psi)}$

---

#### 3.2 Fuel System

Carburetor leakage test at gauge pressure:	$p_{\bar{u}} = 0.8 \text{ bar (11.6 psi)}$
Operation of tank vent at gauge pressure:	$p_{\bar{u}} = 0.3 \text{ bar (4.35 psi)}$
Fuel:	as specified in instruction manual

---

#### 3.3 Ignition System

Air gap between ignition module and fanwheel:	0.15...0.3 mm (0.006...0.12in)
Spark plug (suppressed):	Bosch WSR 6F NGK BPMR 7A
Electrode gap:	0.5 mm (0.02 in)

---

#### 3.4 Chain Lubrication

Fully automatic, speed-controlled oil pump with rotary piston	
Oil delivery rate:	8...18 cm <sup>3</sup> /min (0.49...1.1 cu.in/min) at 10,000 rpm

### 3.5 Tightening Torques

DG screws are used in polymer and light metal components. These screws form a permanent thread when they are installed for the first time. They can be removed and installed as often as necessary without impairing the strength of the screwed assembly, providing the specified tightening torque is observed.

For this reason it is **essential to use a torque wrench**.

Fastener	Thread size	For component	Torque		Remarks
			Nm	(lbf ft)	
Screw	IS-M5x20	Crankcase	11.5	(8.48)	
Screw	IS-M5x20	Cylinder	11.5	(8.48)	
Screw	IS-M5x16	Muffler, lower casing to cylinder	11.0	(8.11)	1)
Screw	IS-M5x6	Muffler, upper casing top	6.5	(4.79)	1)
Screw	IS-M5x16	Muffler top	11.0	(8.11)	1)
Screw	IS-M5x18	Muffler bottom	15.0	(11.06)	1)
Screw	IS-M5x20	Ignition module	7.0	(5.16)	2)3)
Screw	IS-M4x16	Shroud	4.0	(2.95)	
	M12x1 L	Carrier (clutch)	50.0	(36.88)	
	M14x1,25	Spark plug	25.0	(18.44)	
Nut	M5	Carburetor	3.5	(2.58)	
Screw	IS-M4x16	Annular buffer plate	5.0	(3.69)	
Screw	IS-M5x12	Spiked bumper top (with nut)	7.5	(5.53)	
Screw	IS-M5x16	Spiked bumper bottom (chain catcher)	7.5	(5.53)	
Screw	IS-M3,5x12	Generator	2.0	(1.48)	1)
Screw	M4x8	Cover, chain tensioner	3.0	(2.21)	
Screw	IS-M4x12	Oil pump	3.5	(2.58)	
Screw	IS-M4x12	Cover, chain brake	3.0	(2.21)	
Screw	IS-M4x12	Brake band	3.0	(2.21)	1)
Screw	IS-M4x16	Fan housing	4.0	(2.95)	2)
Screw	M4x8	Side plate, inner	3.0	(2.21)	
Nut	M8x1	Crankshaft (flywheel)	33.0	(24.34)	
	M10x1	Decompression valve	14.0	(10.33)	
Collar stud	M8x21,5	Bar mounting	23.0	(16.96)	1)
Polymer screw	IS-P6x26,5	Annular buffer, top	5.5	(4.06)	
Polymer screw	IS-P6x19	Annular buffer, bottom	5.5	(4.06)	
Polymer screw	IS-P6x19	Front handle, top	8.0	(5.90)	4)
Polymer screw	IS-P6x19	Front handle, bottom	8.0	(5.90)	4)
Screw assy.	IS-M4x16	Hand guard left, fan housing	4.0	(2.95)	

#### Remarks:

- 1) Secure screw with Loctite 270
- 2) Secure screw with Loctite 242
- 3) A washer must be fitted under the screw head

**4. Troubleshooting Chart**  
**4.1 Clutch, Chain Drive, Chain Brake, Chain Tensioner**

Condition	Cause	Remedy
Saw chain stops under load at full throttle	Clutch shoes badly worn	Replace clutch shoes
	Clutch drum badly worn	Install new clutch drum
	Brake band stuck	Check freedom of movement and function of brake band.
Saw chain rotates at idle speed	Engine idle speed too high	Adjust idle speed screw (counterclockwise)
	Clutch springs stretched or fatigued	Replace clutch springs
	Clutch spring hooks broken	Replace clutch springs
Loud noises	Clutch springs stretched or fatigued	Replace all clutch springs
	Needle cage damaged	Fit new needle cage
	Clutch shoe retainer broken	Fit new retainer
	Clutch shoes and carrier worn	Install new clutch
Chain sprocket wears rapidly	Chain not properly tensioned	Tension chain as specified
	Wrong chain pitch	Fit chain of correct pitch
	Insufficient chain lubrication	Check chain lubrication
	Chain sprocket worn	Fit new chain sprocket
Saw chain does not stop immediately when brake is activated	Brake spring stretched or broken	Fit new brake spring
	Brake band stretched, worn or broken	Fit new brake band



## 4.2 Rewind Starter

Condition	Cause	Remedy
Starter rope broken	Rope pulled out too vigorously as far as stop or over edge, i.e. not vertically	Fit new starter rope
	Normal wear	Fit new starter rope
Starter rope does not rewind	Rewind spring broken	Fit new rewind spring
	Spring overtensioned – no reserve when rope is fully extended	Fit new rewind spring
	Very dirty or corroded	Clean or replace rewind spring
Starter rope can be pulled out almost without resistance (crankshaft does not turn)	Guide peg on pawls or pawls themselves are worn	Fit new pawls
	Spring clip fatigued	Fit new spring clip
Starter rope is difficult to pull and rewinds very slowly	Starter mechanism is very dirty	Thoroughly clean complete starter mechanism
	Lubricating oil on rewind spring becomes viscous at very low outside temperatures (spring windings stick together)	Coat rewind spring with a little standard solvent-based degreasant (containing no chlorinated or halogenated hydrocarbons), then pull rope carefully several times until normal action is restored

### 4.3 Chain Lubrication

#### Warning!

In the event of trouble with the chain lubrication system, check and rectify other sources of faults before disassembling the oil pump.

Condition	Cause	Remedy
Chain receives no oil	Oil tank empty	Fill up with oil
	O-ring on oil line to crankcase defective or oil line damaged	Remove oil pump, fit a new O-ring and refit or replace the oil pump
	Oil inlet hole in guide bar is blocked	Clean oil inlet hole
	Intake hose or pickup body (strainer) clogged or intake hose ruptured	Clean intake hose and pickup body (strainer) with standard solvent-based degreasant not containing chlorinated or halogenated hydrocarbons / replace intake hose and pickup body
	Valve in oil tank blocked	Clean or replace valve
	Teeth on pump piston and/or worm worn	Install new oil pump and/or new worm
Machine losing chain oil	O-ring on oil line to crankcase defective or oil line damaged	Remove oil pump, fit a new O-ring and refit or replace the oil pump
	Piston bore in pump housing worn	Install new oil pump
Oil pump delivers insufficient oil	Adjusting screw and/or control edge on pump piston worn	Fit new adjusting screw and/or oil pump
	Piston bore in pump housing worn	Install new oil pump

## 4.4 Ignition System

### Warning!

Exercise extreme caution while carrying out maintenance and repair work on the ignition system. The high voltages which occur can cause serious or fatal accidents!

Condition	Cause	Remedy
Engine runs roughly, misfires, temporary loss of power	Spark plug boot is loose	Press boot firmly onto spark plug and fit new spring if necessary
	Spark plug sooted, smeared with oil	Clean the spark plug or replace if necessary
	Incorrect air gap between ignition module and flywheel	Set air gap correctly
	Flywheel cracked or has other damage or pole shoes have turned blue	Install new flywheel
	Ignition timing wrong, flywheel out of adjustment, key in flywheel has sheared off	Install new flywheel
	Weak magnetization in flywheel – pole shoes have turned blue	Install new flywheel
No spark		Check operation of Master Control lever and ignition module
No spark		Faulty insulation on ignition lead or short circuit wire. Use ohmmeter to check ignition lead for break. If break is detected or high resistance measured, fit a new ignition lead
	Leak in crankcase	Replace oil seals or crankcase

## 4.5 Carburetor

Condition	Cause	Remedy
Carburetor floods; engine stalls	Inlet needle not sealing. Foreign matter in valve seat or cone damaged	Remove and clean or replace the inlet needle, clean the fuel tank, pickup body and fuel line if necessary
	Inlet control lever sticking on spindle	Free off inlet control lever
	Helical spring not located on nipple of inlet control lever	Remove the inlet control lever and refit it correctly
	Perforated disc on diaphragm is deformed and presses constantly against the inlet control lever	Fit a new metering diaphragm
	Inlet control lever too high (relative to correct installed position)	Set inlet control lever flush with top edge of housing
Poor acceleration	Idle jet too lean	Rotate low speed screw ( <b>L</b> ) counterclockwise (richer), no further than stop
	Main jet too lean	Rotate high speed screw ( <b>H</b> ) counterclockwise (richer), no further than stop
	Inlet control lever too low (relative to correct installed position)	Set inlet control lever flush with top edge of housing
	Inlet needle sticking to valve seat	Remove inlet needle, clean and refit
	Diaphragm gasket leaking	Fit new diaphragm gasket
	Metering diaphragm damaged or shrunk	Fit new metering diaphragm
	Impulse hose damaged or kinked	Fit new impulse hose

Condition	Cause	Remedy
Engine will not idle, idle speed too high	Throttle shutter opened too wide by idle speed screw ( <b>LA</b> )	Reset idle speed screw ( <b>LA</b> ) correctly
	Oil seals/crankcase leaking	Seal or replace oil seals/crankcase
Engine stalls at idle speed	Idle jet bores or ports blocked	Clean jet bores and ports, and blow through with compressed air
	Idle jet too rich or too lean	Set low speed screw ( <b>L</b> ) correctly
	Setting of idle speed ( <b>LA</b> ) incorrect – throttle shutter completely closed	Set idle speed screw ( <b>LA</b> ) correctly
	Small plastic plate in valve jet does not close	Clean or renew valve jet
Engine speed drops quickly under load – low power	Air filter dirty	Clean the air filter
	Throttle shutter not opened fully	Check actuation
	Tank vent faulty	Clean tank vent or replace if necessary
	Fuel pickup body dirty	Clean the pickup body, fit a new filter
	Fuel strainers dirty	Replace the fuel strainers
	Leak in fuel line between tank and fuel pump	Seal connections or install a new fuel line
	Pump diaphragm damaged or fatigued	Fit new pump diaphragm
	Main jet bores or ports blocked	Clean bores and ports
	Setting of high speed screw ( <b>H</b> ) too rich	Rotate high speed screw ( <b>H</b> ) clockwise (leaner), no further than stop
Impulse hose damaged or kinked	Fit new impulse hose	

## 4.6 Engine

Always check and, if necessary, repair the following parts before looking for faults on the engine:

Air filter  
Fuel system  
Carburetor  
Ignition system

Condition	Cause	Remedy
Engine does not start easily, stalls at idle speed, but operates normally at full throttle.	Oil seals in crankcase damaged	Replace the oil seals
	Crankcase leaking or damaged (cracks)	Seat or replace the crankcase
	Leak in muffler	Seal / replace muffler
Engine does not deliver full power or runs erratically	Piston rings worn or broken	Replace piston rings
	Muffler / spark arresting screen carbonized	Clean muffler (inlet and exhaust opening), replace spark arresting screen
	Air filter insert soiled	Replace air filter insert
	Fuel / impulse hose severely kinked or damaged	Fit new hoses or position them free from kinks
	Decompression valve sticking	Replace the decompression valve
Engine overheating	Insufficient cylinder cooling. Air inlets in fan housing blocked or cooling fins on cylinder very dirty	Thoroughly clean all cooling air openings and the cylinder fins.

## 5. Clutch, Chain Drive, Chain Brake and Chain Tensioner

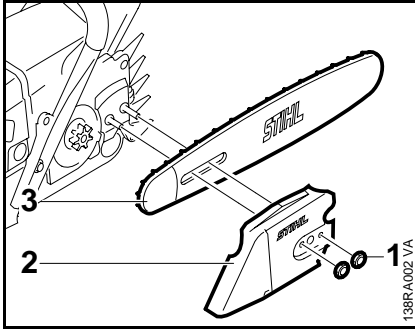

Wear work gloves to protect your hands from injury.

- Unscrew the hex nuts (1) on the chain sprocket cover (2) and remove chain sprocket cover and guide bar (3).

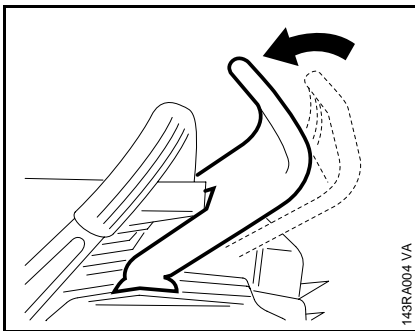

- Disengage the chain brake by pulling the hand guard towards the front handle.

## 5.1 Clutch Drum / Chain Sprocket

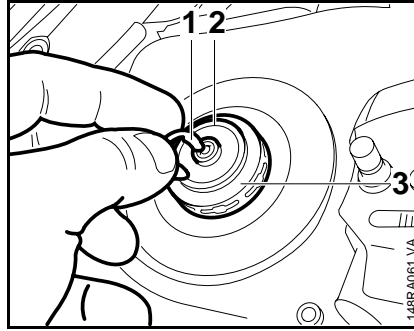

- Remove the E-clip (1), washer (2) and rim sprocket (3) if fitted.

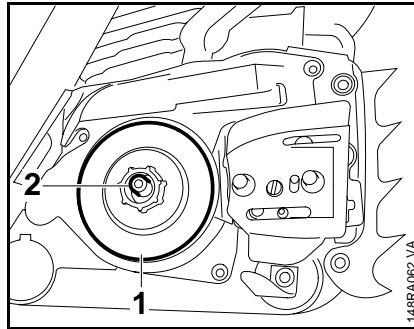

- Remove the clutch drum (1) with needle cage (2).
- Examine the needle cage for signs of damage.

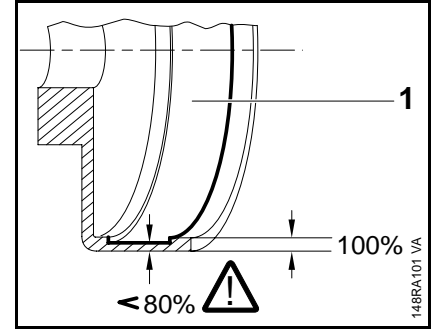

- Inspect the clutch drum (1).

If there are signs of serious wear on the inside diameter of the clutch drum (1), check the remaining wall thickness. If it is less than about 80% of the original thickness, fit a new clutch drum.

If the clutch drum has to be replaced, also check the brake band –  5.4.2

## 5.2 Replacing the Chain Catcher

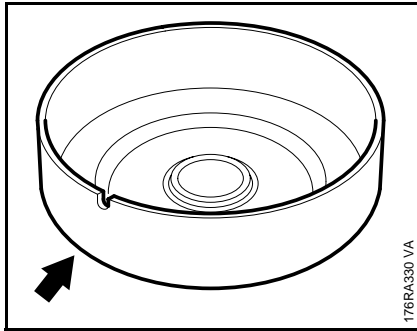

If the clutch drum can be reused, clean and roughen the friction surface.

Reassemble in the reverse sequence.

Clean stub of crankshaft. Wash needle cage, examine it for damage and replace if necessary. Lubricate needle cage with STIHL multi-purpose grease – 16.

- Rotate clutch drum / chain sprocket and apply slight pressure at the same time until the oil pump drive spring engages in the slot on the circumference.

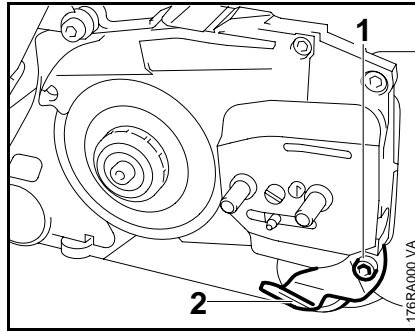

- Remove the chain sprocket cover – 5.1

- Take out the screw (1) and remove the chain catcher (2).

Reassemble in the reverse sequence.

## 5.3 Clutch

Troubleshooting chart – 4.1

- Remove the clutch drum/chain sprocket – 5.1

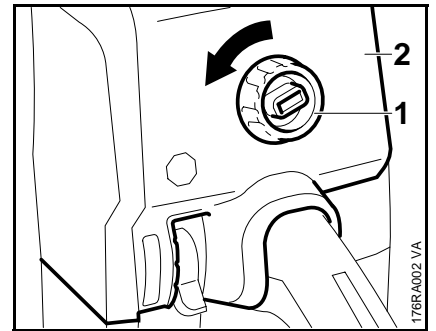

- Release twist lock (1) on carburetor box cover (2) and lift it off.

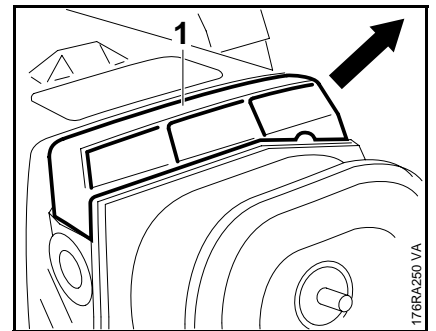

- On machines with HD air filter, draw air guide (1) off to the rear.



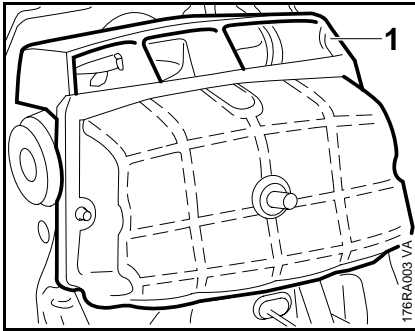

- On machines with box filter, remove air filter (1).
- Pull the boot off the spark plug and unscrew the spark plug.

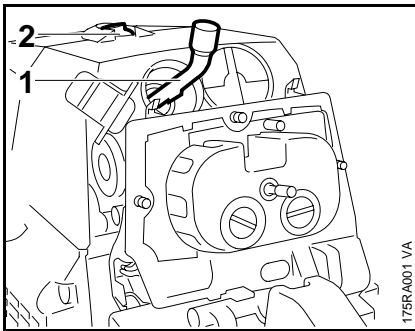

- Close the decompression valve if fitted, carefully prising the button (2) upwards for this purpose.
- Push the locking strip (1) 0000 893 5903 into the spark plug hole so that "OBEN-TOP" faces up.

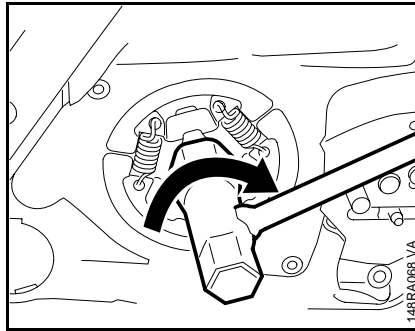

- Unscrew the clutch (1) from the crankshaft clockwise (left-hand thread).

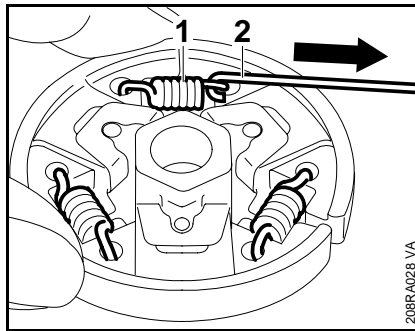

#### Disassembling the clutch

- Use hook (2) 5910 890 2800 to remove the clutch springs (1).
- Pull the clutch shoes off the carrier.

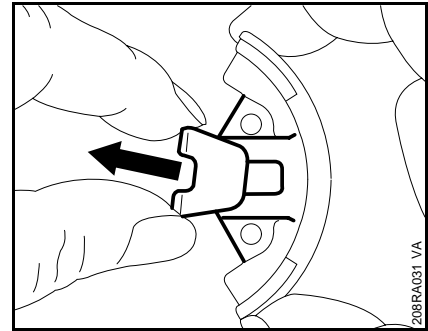

- Pull the retainers off the clutch shoes.

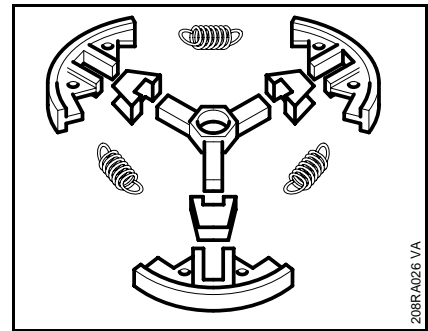

- Clean all parts.
- Replace any damaged parts.

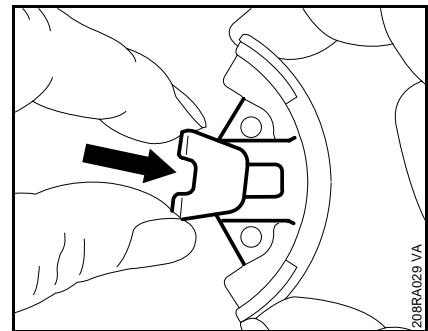

#### Assembly

- Slip the retainers onto the clutch shoes.

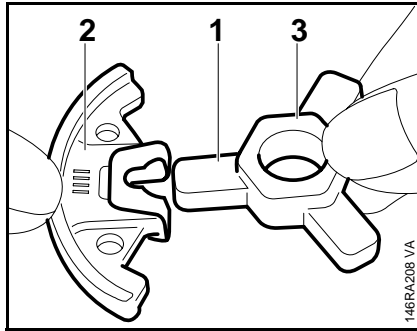

- Fit the clutch shoes over the arms (1) of the clutch carrier so that the series number (2) is on the same side as the longer hexagon (3).

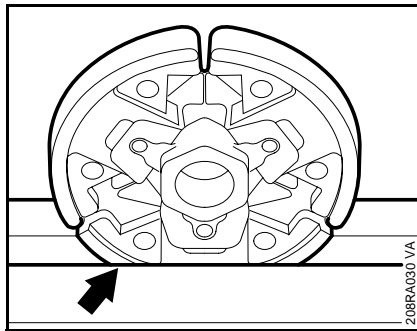

- Clamp the clutch in a vise.

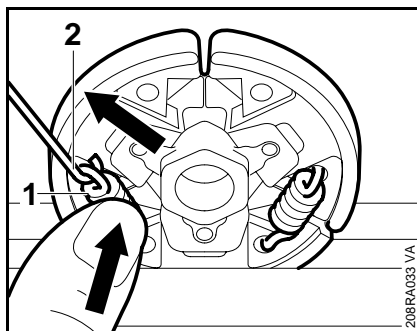

- Attach one end of each spring (1) to the clutch shoes.
- Use the hook (2) 5910 890 2800 to attach other end of the spring and press it firmly into the clutch shoe.

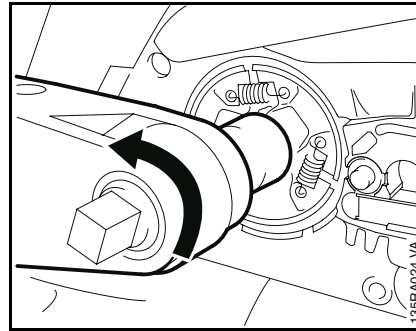

- Screw home the clutch, turning counterclockwise, and tighten it down firmly – 3.5
- Remove locking strip from the cylinder.
- Turn in the spark plug and tighten it down firmly – 3.5
- Plug the boot onto the spark plug.
- Refit the shroud.
- Fit the clutch drum / chain sprocket – 5.1

Ensure that the grooves in the shroud are correctly positioned when assembling the parts.

## 5.4 Chain brake

### 5.4.1 Checking correct operation

The chain brake is one of the most important safety devices on the chainsaw. Its efficiency is measured in terms of the chain braking time, i.e. the time that elapses between activating the brake and the saw chain coming to a complete standstill. The shorter the braking time, the better the efficiency and protection offered against being injured by the rotating chain.



Contamination (with chain oil, chips, fine particles of abrasion, etc.) and smoothing of the friction surfaces of the brake band and clutch drum impair the coefficient of friction. This, in turn, reduces the frictional forces and thus prolongs the braking time. A fatigued or stretched brake spring has the same negative effect.

- Start the engine.
- With the chain brake activated (locked), open the throttle wide for a brief period (max. 3 seconds) – the chain must not rotate.
- With the chain brake released, open the throttle wide and activate the brake manually – the chain must come to an abrupt stop.

The braking time is in order if deceleration of the saw chain is imperceptible to the eye.

If the chain brake does not operate properly, see troubleshooting chart – 4.1.

## 5.4.2 Removing

- Remove the chain sprocket cover and guide bar –  5.1
- Remove the clutch –  5.3

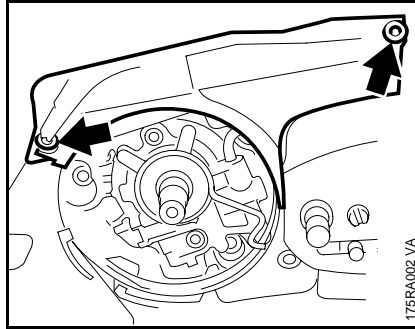

- Take out the screws (arrows).
- Remove the cover.
- Release the brake spring by pushing the hand guard forwards.

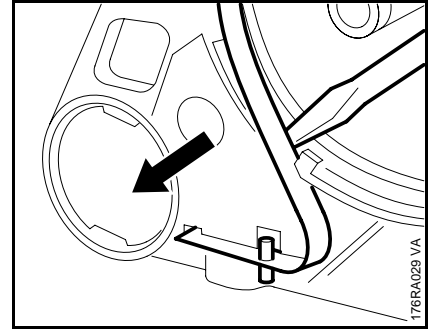

- Ease the brake band out of the engine housing.

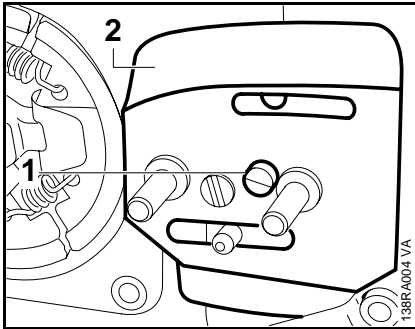

- Take out the screw (1) of the inner side plate (2) and remove the side plate.
- Engage the chain brake by pushing the hand guard away from the front handle.

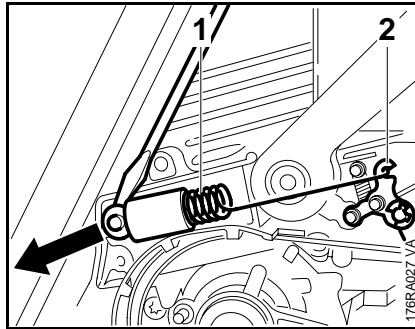

- Carefully ease the brake spring (1) off the anchor pin and remove it from the bell crank (2).

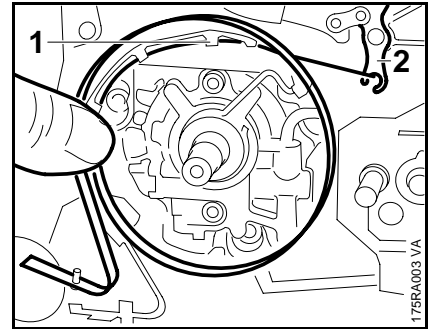

- Remove the brake band from the stubs (1) on the crankcase.
- Unhook the brake band from the bell crank (2).

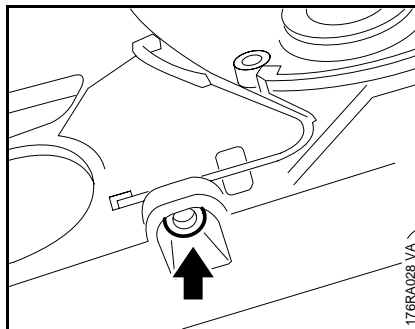

- Take out the screw (arrow) on the brake band.

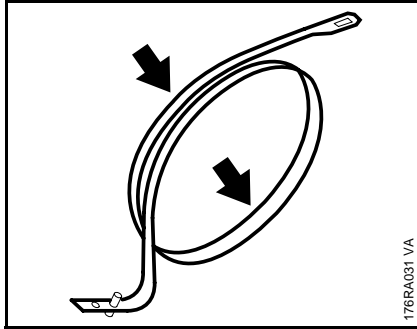

176RA031 VA

Install a new brake band if:

- there are noticeable signs of wear (large areas on inside diameter and/or parts of outside diameter) and
- its remaining thickness is less than 0.6 mm (0.02 in).

This minimum thickness must remain **at all points**.

- If the brake band can be reused, clean and roughen the entire friction surface.

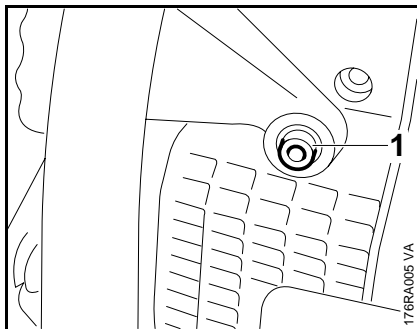

176RA005 VA

- Take out the screw (1).

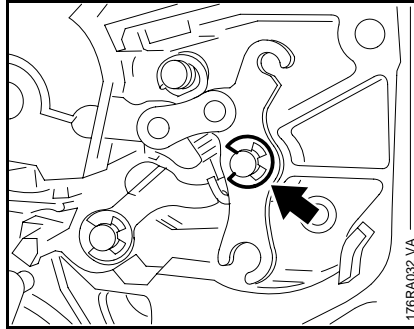

176RA032 VA

- Remove the E-clip (arrow).

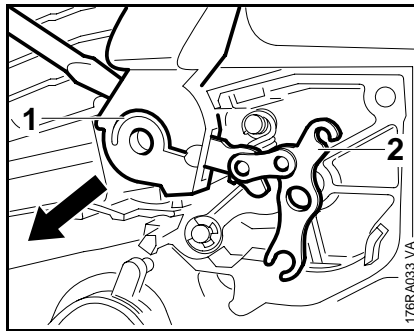

176RA033 VA

- Carefully pry the hand guard (1) and bell crank (2) off the pivot pins and remove all parts.
- Draw the bell crank out of the hand guard.

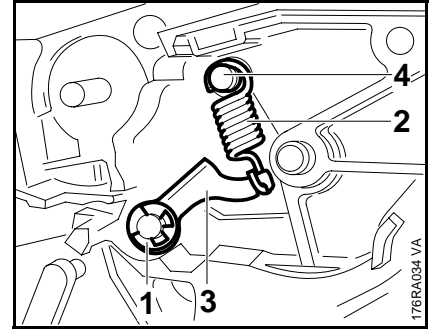

176RA034 VA

- Remove the E-clip (1).
- Disconnect the spring (2) and remove the cam lever (3).
- Examine the parts and replace any defective elements.
- Clean the entire installation area of the chain brake.
- If the groove on the pin (4) for the brake spring is worn, the pin must be replaced.
- Remove the cylinder – 6.5.1

### 5.4.3 Installing

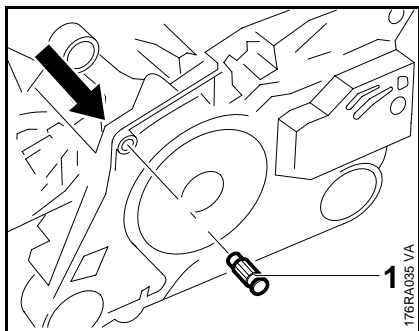

- Drive the pin (1) out of the crankcase with a drift in the direction indicated.

Do not drive out the pin in the other direction as this would damage the annular bead which was formed in the crankcase bore when the pin was originally installed. In such a case neither the new anchor pin nor the brake spring would locate properly. Furthermore, the crankcase could be damaged in this way and possibly impair correct operation of the chain brake.

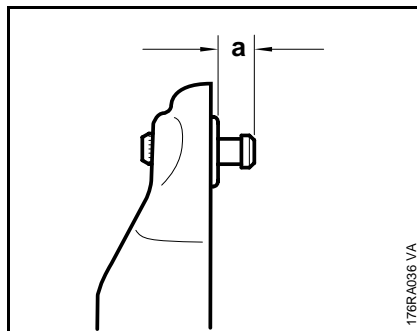

- Carefully tap home the pin squarely to obtain dimension "a" (about 4.3–4.7 mm) (0.17–0.19 in).

The pin must be driven home absolutely square.

- Install the cylinder – 6.5.2
- Coat all sliding and bearing points with STIHL multipurpose grease – 16.

- Before installing the new pin, coat its knurled shank with Loctite – 16.
- Position the new pin in the bore so that the knurling on the pin meshes with the existing knurling in the bore. Turn pin back and forth as necessary.

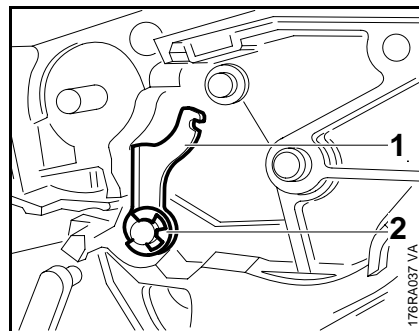

- Fit the cam lever (1).
- Fit the E-clip (2).

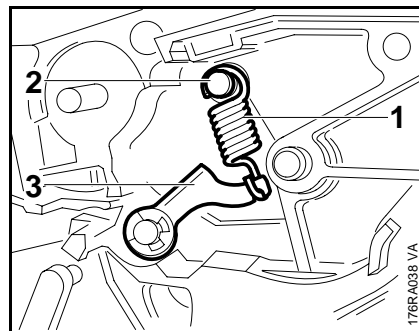

- Hook the spring (1) into the pivot pin (2) and cam lever (3).
- Examine the reflector foil on the hand guard and replace it if necessary.

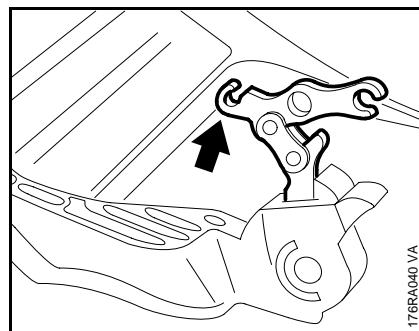

- Slide the bell crank into the opening at the side of the hand guard.

The short end of the lever (arrow) faces the upper part of the hand guard.

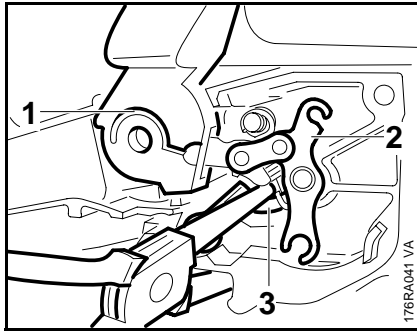

- Position the bearing boss of the hand guard (1) against the pivot pin and fit the other side over the housing.
- Position the bell crank (2) against the pivot pin.
- Lightly press the cam lever (3) down, pressing the hand guard and bell crank onto the pivot pins at the same time.
- Tighten the hand guard screw – 3.5

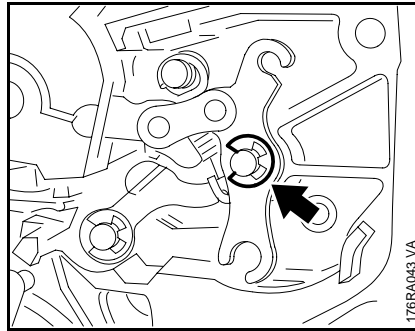

- Secure the bell crank with the E-clip (arrow).
- Coat the brake band with chain oil to protect it against corrosion and to soften the "hard blow" of the brake when braking for the first few times.

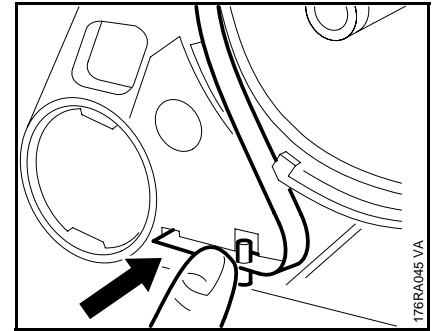

- Push the brake band into the slot.
- Turn the screw in with Loctite – 16.
- Tighten down the screw – 3.5

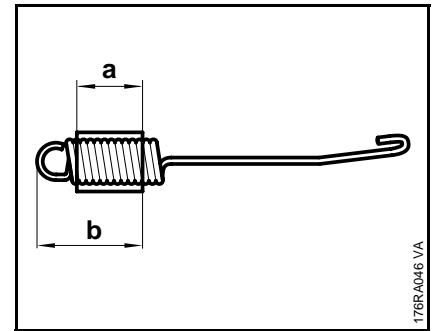

- Turns of brake spring must be tightly against one another in the relaxed condition. If this is not the case, replace the brake spring.
- Check correct position of the protective tube  
 $a = 20 \text{ mm (0.79 in)}$   
 $b = 32 \text{ mm (1.26 in)}$

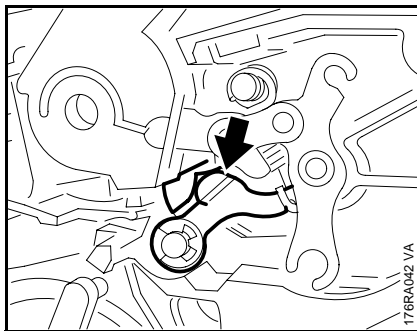

- Check that the cam lever is correctly positioned on the sliding surface (arrow) of the bearing boss.

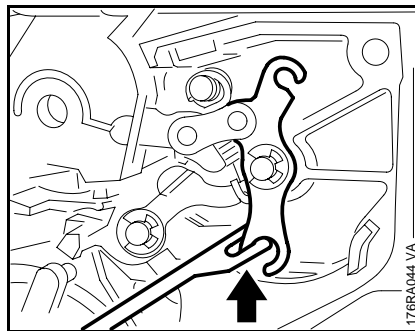

- Hook the brake band into the bell crank (arrow).
- Route the brake band round behind the stubs on the crankcase.

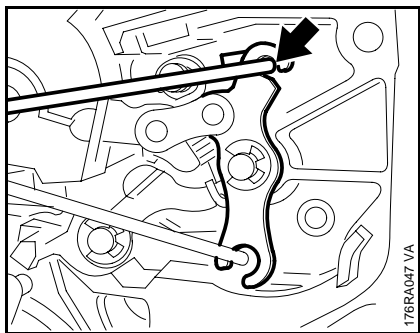

- Hook the brake spring into the slot on the bell crank (arrow).

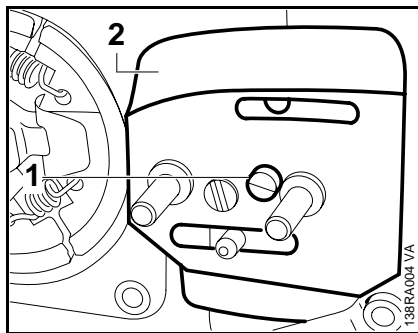

- Slide the side plate (2) onto the collar screws and position it against the crankcase.
- Insert the screw (1) and tighten it down.
- Fit the guide bar and chain sprocket cover, then tighten down the nuts on the chain sprocket cover – 3.5
- Check correct operation of the chain brake – 5.4.1

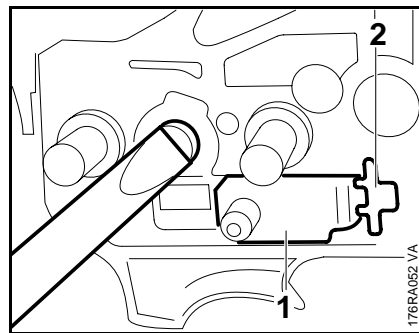

- Remove the inner side plate – 5.4.2
- Use a screwdriver to turn the spur gear clockwise until tensioner slide (1) butts against the thrust pad (2).

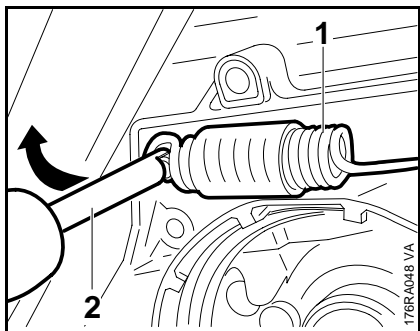

- Use the assembly tool (2) 1117 890 0900 to attach the brake spring (1) to the anchor pin.

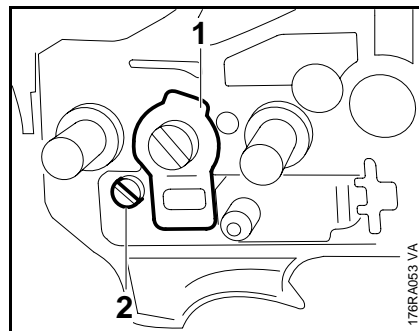

- Remove the retainer (1).
- Take out the screw (2).

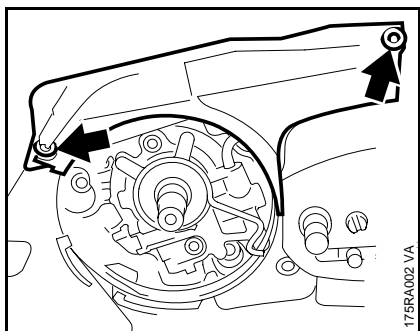

- Fit the cover.
- Turn in the screws (arrows) and tighten them down – 3.5
- Fit the clutch drum / chain sprocket – 5.1

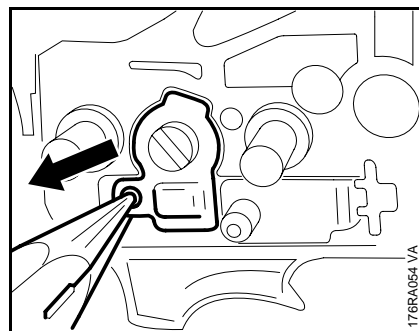

- Remove the cover plate.

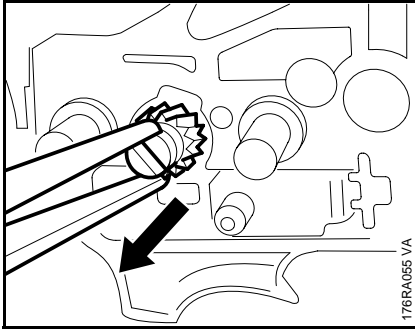

- Pull out the spur gear.

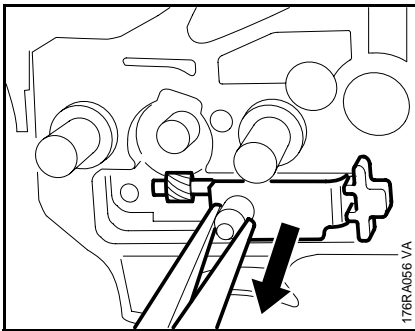

- Pull out the tensioner slide with adjusting screw and thrust pad.

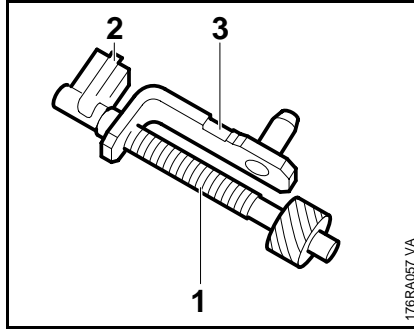

- Inspect the teeth on the spur gear and adjusting screw (1), and replace both parts if necessary. To do this, pull off the thrust pad (2) and unwind the adjusting screw from the tensioner slide (3).

Always replace the adjusting screw and spur gear as a matching pair.

Reassemble in the reverse sequence.

- Before installing, lubricate teeth on adjusting screw and spur gear with grease – 16.

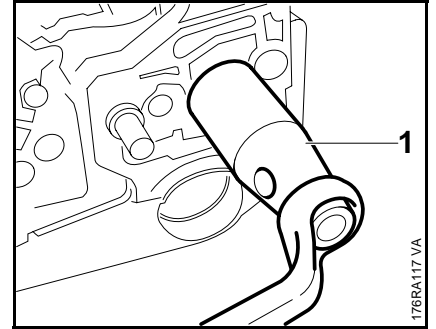

- Remove chain sprocket cover and cutting attachment – 5.1

- Push stud puller (1) 5910 893 0501 over the collar stud as far as it will go. Use a 15 mm (0.60 in) wrench to unscrew the collar stud counterclockwise.

- Before installing, coat thread of collar stud with LOCTITE – 16.

- Fit the collar stud and tighten it down firmly – 3.5

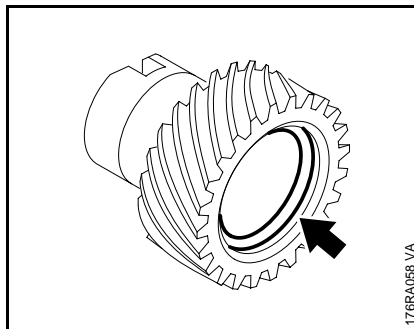

- Check that the O-ring (arrow) is fitted in the spur gear and lubricate it with oil before installing the spur gear.



## 6. Engine

### 6.1 Muffler / Spark Arresting Screen

Always check and, if necessary, repair the fuel system, carburetor, air filter and ignition system before looking for faults on the engine.

Troubleshooting chart –  4.6

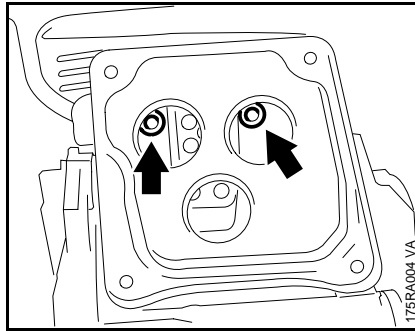

- Take out the screws (arrows).
- Remove the inlet casing.
- Remove the gasket and heat shield.
- Check the spark arresting screen if fitted, bend the retaining lugs back and pull out the spark arresting screen (except on the MS 440 Magnum).
- Clean the spark arresting screen or replace it if necessary.

On the MS 440 Magnum, proceed as follows to clean the spark arresting screen:

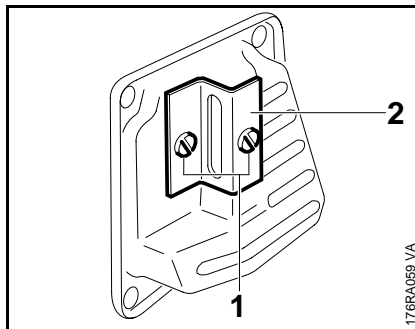

#### MS 440 Magnum only

- Take out the screws (1).
- Remove the cover plate (2).

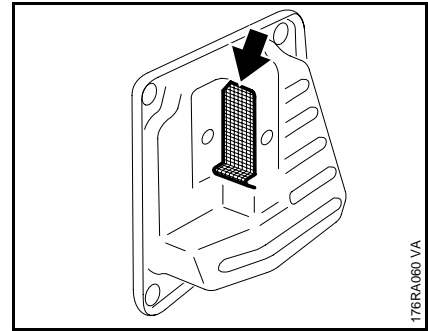

- Remove the spark arresting screen (arrow).
- Clean the spark arresting screen or replace it if necessary.

#### Versions with catalytic converter only

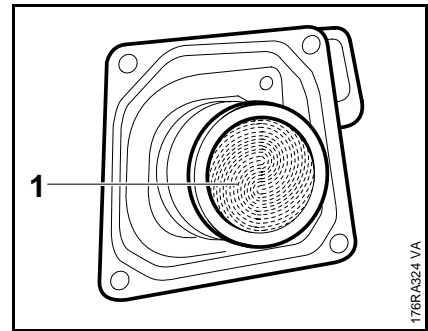

- If there are cracks in the honeycomb structure (1) or if the steel jacket enclosing the honeycomb is defective, the catalytic converter must be replaced in order to prevent damage to the engine.

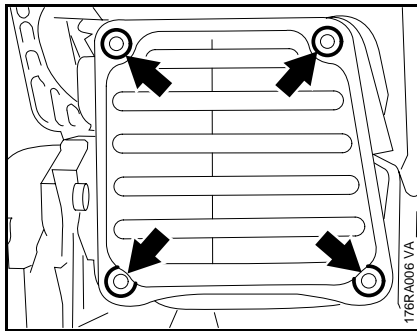

- Take out the screws (arrows).
- Remove the exhaust casing.

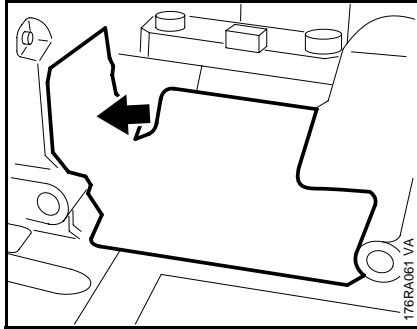

- Examine the reflector foil (arrow) and replace it if necessary – 6.7.2

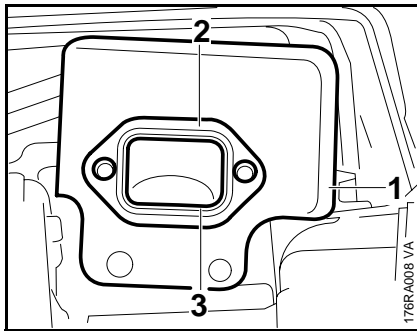

- Fit the heat shield (1) in position.
- Position a new gasket (2) with the bead (3) facing outwards.
- Coat the screw threads with Loctite – 16.
- Tighten down the screws – 3.5

When assembling the parts, ensure that size M6x20 screws are fitted at the bottom and size M5x6 screws at the top to secure the exhaust casing.

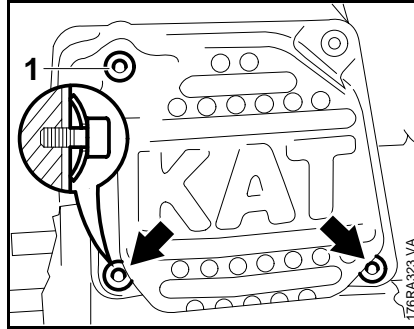

**Versions with catalytic converter only**

- Fit M6x30 screws (arrows) with tensioning gear.
- Insert M5x30 screw (1) with sleeve.

Defective oil seals and gaskets or cracks in castings are the usual causes of leaks. Such faults allow supplementary air to enter the engine and upset the fuel-air mixture.

This makes adjustment of the prescribed idle speed difficult, if not impossible.

Moreover, the transition from idle speed to part or full throttle is not smooth.

The crankcase can be checked thoroughly for leaks with the carburetor and crankcase tester and the vacuum pump.

## 6.2.1 Preparations

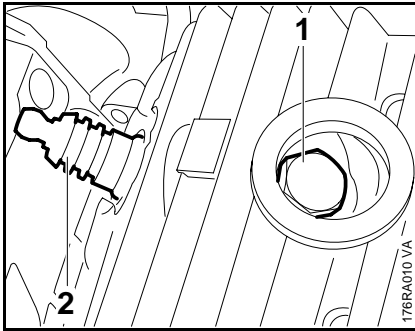

- Remove the decompression valve, if fitted – 6.8
- Install plug (1) 1122 025 2200 and tighten down to 25 Nm (18.44 lbf ft).
- Fit spark plug (2) and tighten it down firmly – 3.5

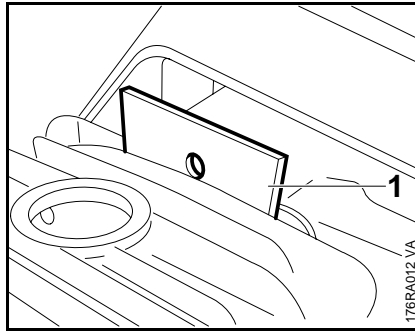

- Slide the sealing plate (1) 0000 855 8106 between the heat shield and cylinder exhaust port, then tighten down the muffler screws again.

The sealing plate must completely fill the space between the two screws.

- Remove the carburetor – 12.2.1
- Set the piston to top dead center. This can be checked through the inlet port.

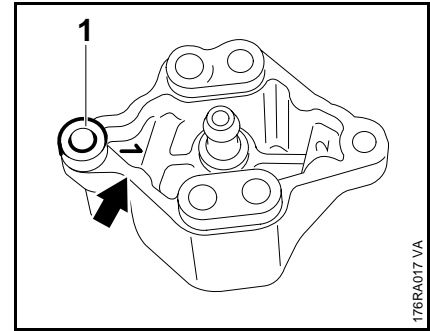

Ensure that the pin (1) is located in hole No. 1 of the test flange 1128 850 4200. If not, it must be screwed in.

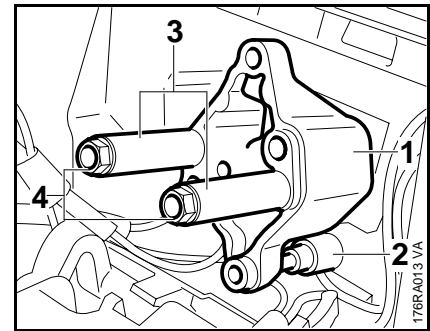

- Slide the test flange (1) into place.

The pin must engage properly in the impulse hose (2) when positioning the test flange.

- Fit the sleeves (3) 0000 963 1008.
- Fit nuts (4) and tighten them down firmly.

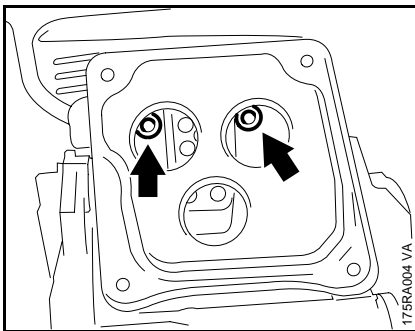

- Remove the exhaust casing on the muffler – 6.1
- Half-remove the screws (arrows) on the muffler.

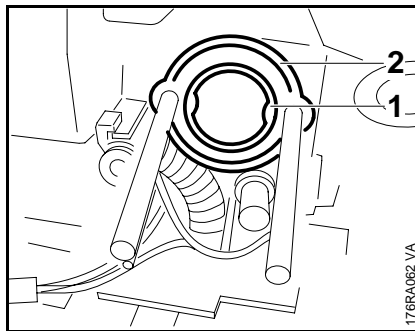

- Ensure that the sleeve (1) and washer (2) are fitted.

## 6.2.2 Pressure Test

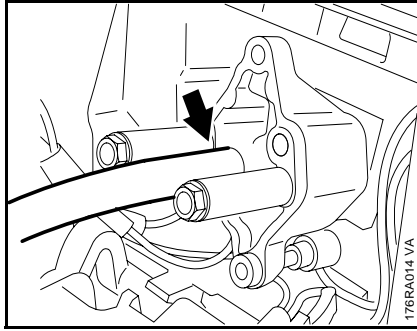

- Remove the carburetor and prepare for testing – 6.2.1.
- Connect pressure hose of tester 1106 850 2905 to nipple (arrow) on test flange.

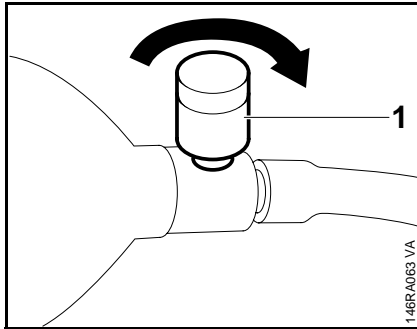

- Close vent screw (1) on the rubber bulb.

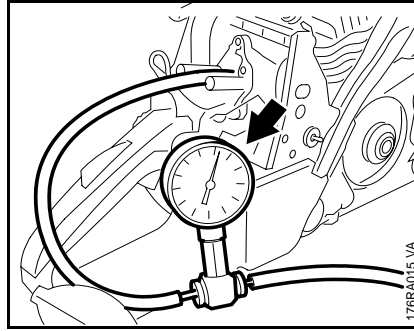

- Pump air into the crankcase with rubber bulb until the gauge (arrow) indicates a pressure of 0.5 bar (7.25 psi). If this pressure remains constant for at least 20 seconds, the crankcase is airtight.

- However, if the pressure drops, the leak must be located and the faulty part replaced.

To find the leak, coat the suspect area with oil and pressurize the crankcase. Bubbles will appear if a leak exists.

- After finishing the test, open the vent screw and disconnect the hose of tester 1106 850 2905.
- Continue with vacuum test – 6.2.3

## 6.2.3 Vacuum Test

Oil seals tend to fail when subjected to a vacuum, i.e. the sealing lip lifts away from the crankshaft during the piston's induction stroke because there is no internal counterpressure.

An additional test can be carried out with the vacuum pump to detect this kind of fault. Carry out the same preparations as for the pressure test – 6.2.2

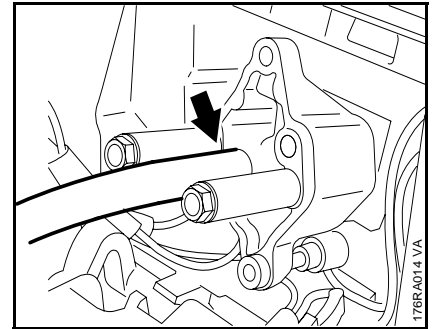

- Connect suction hose of vacuum pump 0000 850 3501 to nipple (arrow) of the test flange.

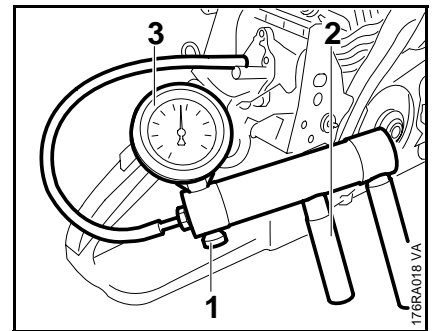

- Close the vent screw (1) on the pump.
- Operate lever (2) until pressure gauge (3) indicates a vacuum of 0.5 bar (7,25 psi).

### 6.3 Oil Seals

If the vacuum reading remains constant, or rises to no more than 0.3 bar (4.35 psi) within 20 seconds, it can be assumed that the oil seals are in good condition. However, if the pressure continues to rise (reduced vacuum in the crankcase), the oil seals must be replaced, even if no leaks were detected in the pressure test.

- After finishing the test, open the vent screw and disconnect the hose.
- Remove the test flange.
- Install the carburetor – 12.2.1
- Undo the muffler screws and remove the sealing plate.
- Take out the muffler screws in succession and refit them with Loctite – 16.

For further assembly of the muffler – 6.1

- Unscrew the plug from the cylinder if necessary.
- Install the decompression valve, if fitted – 6.8

It is not necessary to disassemble the complete crankcase to replace the oil seals.

#### Fan side:

- Remove the flywheel – 7.3.1

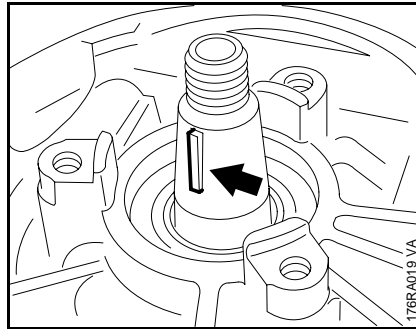

- Remove the key (arrow).

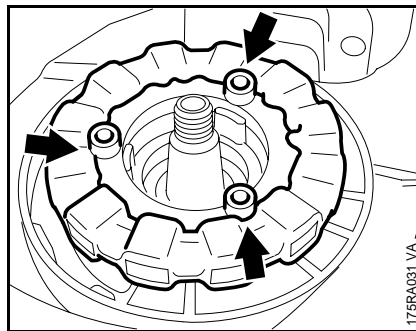

- Take out the screws (arrows) on machines with handle heating.
- Lay the generator aside.

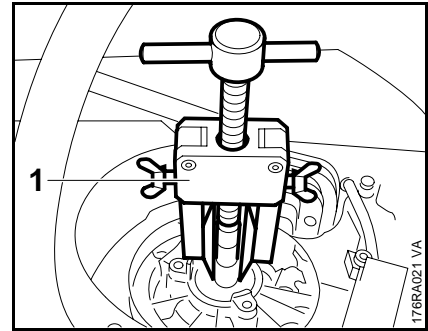

- Free off the oil seal in its seat by tapping it with a suitable tube or a punch.
- Apply puller (1) 5910 890 4400 with No. 6 jaws 0000 893 3711.
- Clamp the puller arms.
- Pull out the oil seal.

Take care not to damage the crankshaft stub.

- The crankshaft sealing face and taper must be free from grease. Clean with standard solvent-based degreasant containing no chlorinated or halogenated hydrocarbons – 16.
- Lubricate sealing lip of oil seal with grease – 16.
- Thinly coat the outside of the oil seal with sealant – 16.
- Slip the oil seal, open side facing the crankcase, over the crankshaft stub.

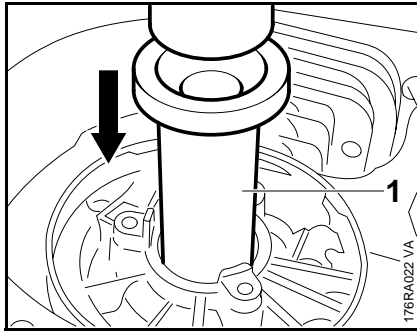

- Use the press sleeve (1) 1128 890 3900 to install the oil seal.

The seating face must be flat and free from burrs.

- Wait about one minute, then rotate the crankshaft several times.
- Install the generator (if fitted) and tighten down the screws firmly – 3.5
- Fit the flywheel – 7.3.

#### Clutch side

- Remove the oil pump – 11.3.1

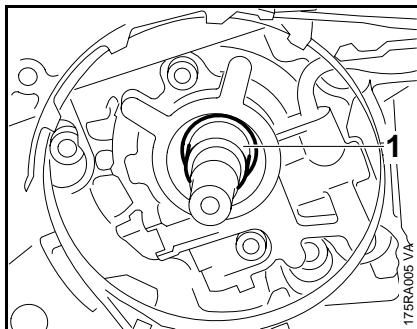

- Remove the spacer bush (1).
- Free off the oil seal in its seat by tapping it with a suitable tube or a punch.

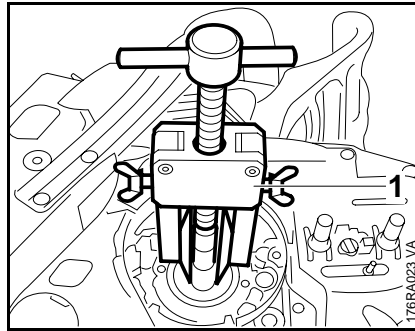

- Apply puller (1) 5910 890 4400 with No. 3.1 jaws 0000 893 3706.
- Clamp the puller arms.
- Pull out the oil seal.

Take care not to damage the crankshaft stub.

- Cleaning sealing face with standard solvent-based degreasant containing no chlorinated or halogenated hydrocarbons – 16.
- Lubricate sealing lip of oil seal with grease – 16.
- Thinly coat the outside of the oil seal with sealant – 16.

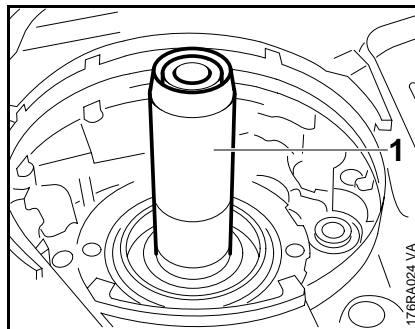

- Push the installing sleeve (1) 1122 893 4600 on to the crankshaft stub.

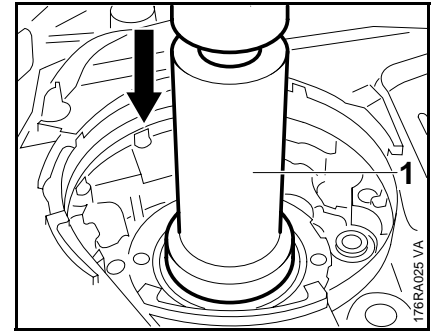

- Slip the oil seal, open side facing the crankcase, over the crankshaft stub.
- Use press sleeve (1) 1118 893 2401 to install the oil seal.
- Remove the installing sleeve.
- Wait about one minute, then rotate the crankshaft several times.
- Reassemble all other parts in the reverse sequence.

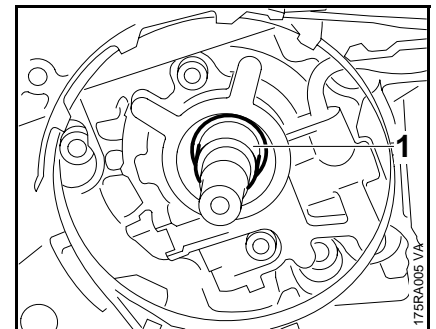

- Grease the outside of the spacer bush – 16.
- Fit the spacer bush.
- Install the oil pump – 11.3.1

## 6.4 Removing the shroud

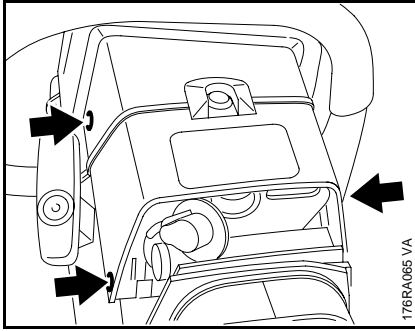

- Remove the spark plug – 5.3
- Take out the screws (arrows) on the shroud.
- Remove the shroud.

Reassemble in the reverse sequence.

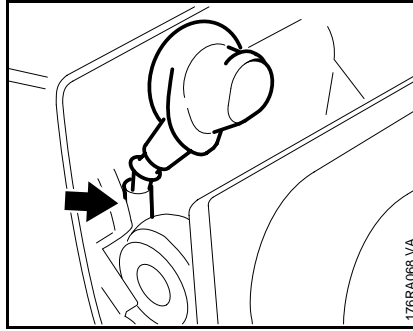

- Position the shroud, ensuring that the ignition lead is correctly located in the notch (arrow).

Reassemble all other parts in the reverse sequence.

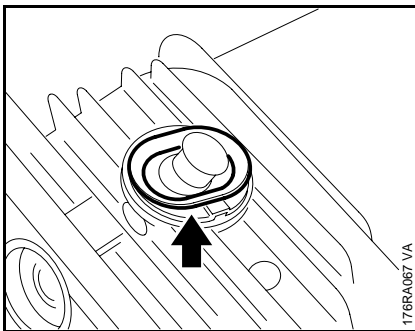

- If a decompression valve is installed, check that the cover (arrow) is correctly seated.

## 6.5 Cylinder and Piston 6.5.1 Removing

Before removing the piston, decide whether or not the crankshaft has to be removed as well. The crankshaft has to be blocked to remove the flywheel and clutch by resting the piston on the wooden assembly block with the cylinder removed or loosened.

- Remove the muffler – 6.1
- Remove the spark plug – 5.3
- Remove the shroud – 6.4
- Remove the carburetor – 12.2.1

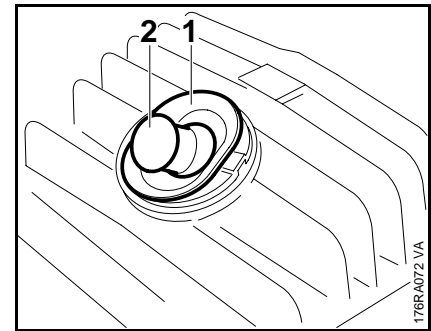

- Remove the cover (1) if fitted and unscrew the decompression valve (2).

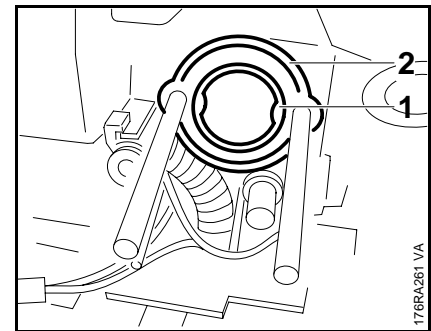

- Take the sleeve (1) out of the manifold.
- Remove the washer (2) from the stud bolts.

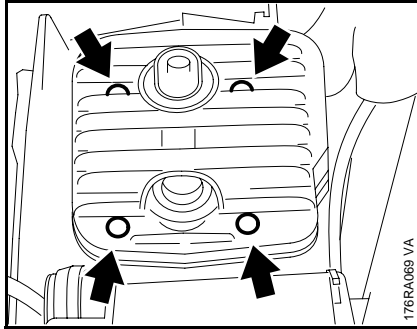

- Unscrew the cylinder base screws through the holes (arrows) in the cylinder.

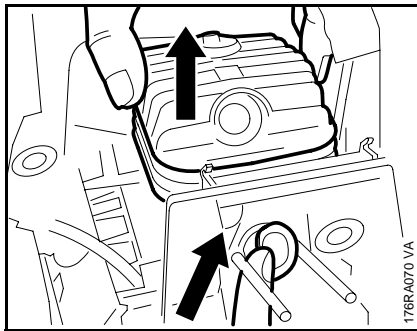

- Carefully lift the cylinder and, at the same time, push the manifold through the tank housing opening.

Do not use pointed or sharp-edged tools for this job.

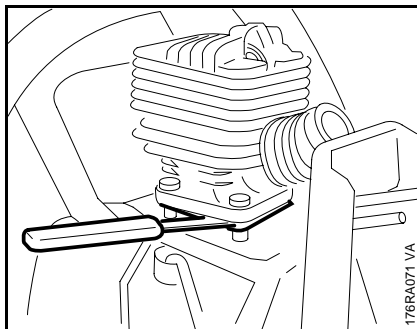

- Carefully remove the cylinder gasket from the cylinder base.
- Pull the cylinder off the piston.
- Remove the cylinder gasket.

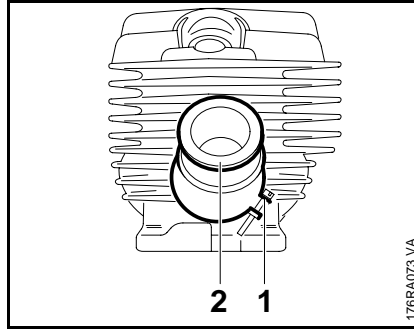

- Open the hose clamp (1).
- Pull the manifold (2) off the intake stub.
- Inspect the cylinder for damage and scores and replace if necessary.
- If a new cylinder has to be installed, **always** fit a new matching piston.
- Before removing the piston, decide whether or not the crankshaft has to be removed as well. The crankshaft has to be blocked to remove the flywheel and clutch by resting the piston on the wooden assembly block with the cylinder removed or loosened.

- Remove the clutch – 5.3
- Remove the flywheel – 7.3

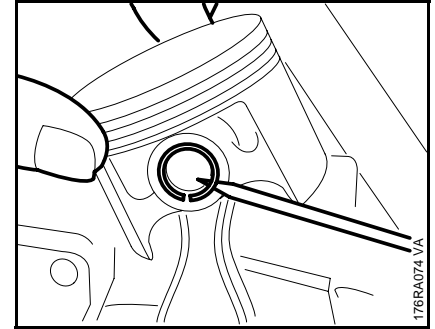

- Remove the hookless snap rings from the piston.

Wear safety glasses to protect your eyes when working with snap rings!

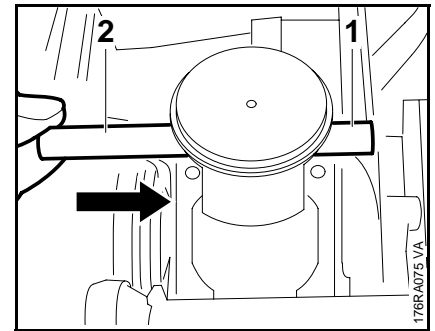

- Use the assembly drift (2) 1111 893 4700 to push the piston pin (1) out of the piston.

If the piston pin is stuck, tap the end of the drift **lightly** with a hammer if necessary.

**Hold the piston steady** during this process to ensure that no jolts are transmitted to the connecting rod.

- Remove the piston from the connecting rod and take the needle cage out of the small end.
- Inspect the piston rings and replace if necessary – 6.6



## 6.5.2 Installing

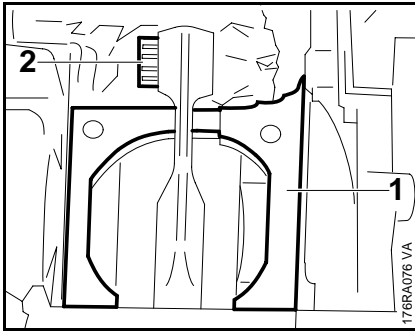

- Thoroughly clean the gasket seating surface (1).
- Lubricate the needle cage (2) with oil and fit it in the small end.

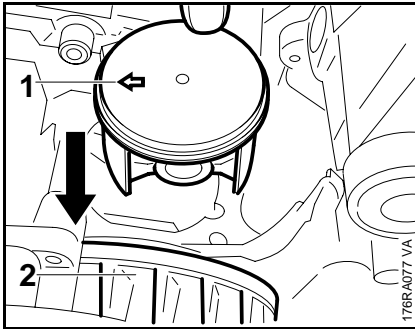

- Note the installed position of the piston:  
1 = Mark  
2 = Flywheel
- Heat the piston to approx. 60 °C (140 °F) on a hotplate, then slide it over the connecting rod.

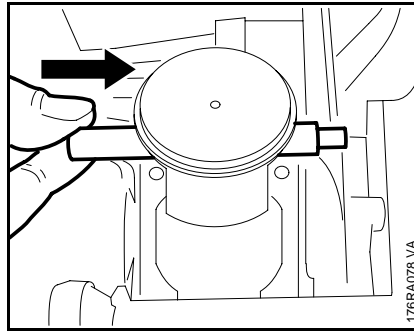

- Push the assembly drift 1110 893 4700, small diameter first, through the piston and small end (needle cage) and line up the piston.

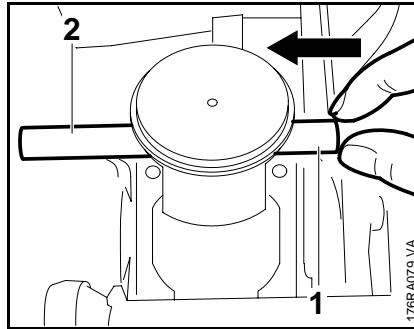

- Fit the piston pin (1) on the assembly drift (2) and slide it into the piston.

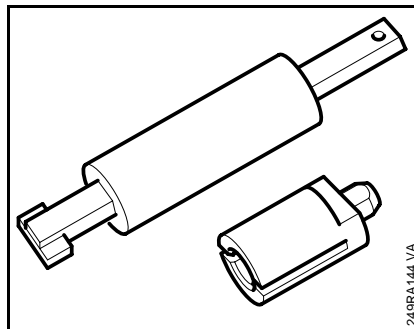

- Remove the sleeve from installing tool 5910 890 2212.

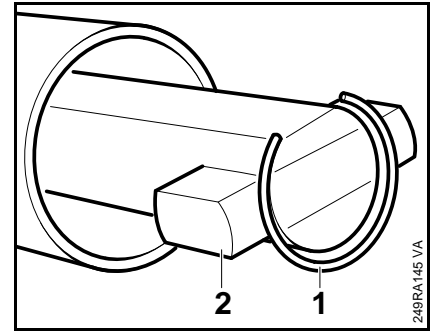

- Attach the snap ring (1) to the magnet (2) so that the snap ring gap is on the flat side of the tool's shank.

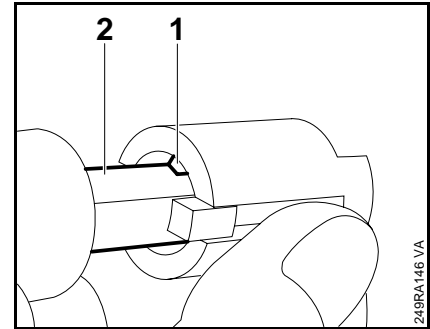

- Push the large slotted diameter of the sleeve over the magnet and snap ring. Position the sleeve so that the inner pin (1) points toward the flat face (2) of tool's shank.

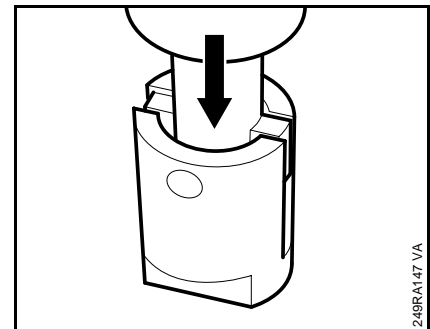

- Stand the installing tool, sleeve downward, on a flat surface (wooden board) and press vertically downwards until the sleeve butts against the tool's shoulder.

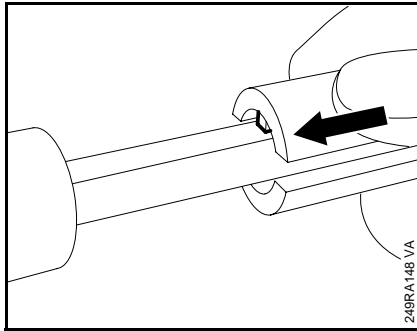

- Remove the sleeve and slip it onto the other end of the shank.

Inner pin must again point toward flat face.

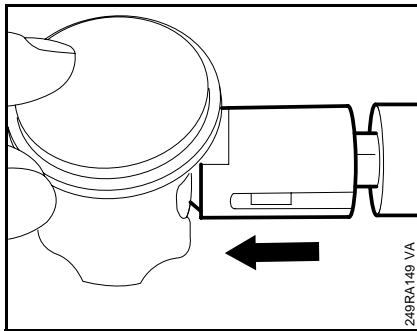

- Apply the installing tool (5910 890 2212) to the piston boss, hold the piston steady, center the tool shank exactly and press home until the snap ring slips into the groove.

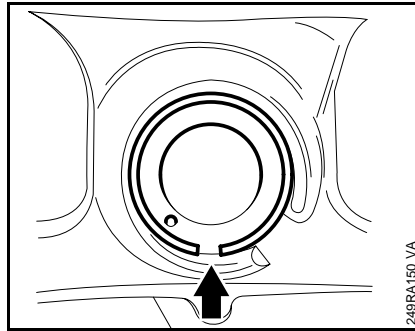

Fit the snap rings so that their gaps are on the piston's vertical axis (they must point either up or down – see arrow).

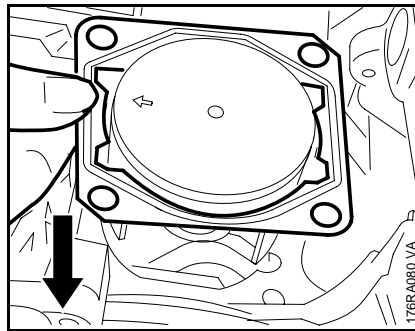

- Fit new cylinder gasket, curvature facing down, on the crankcase.

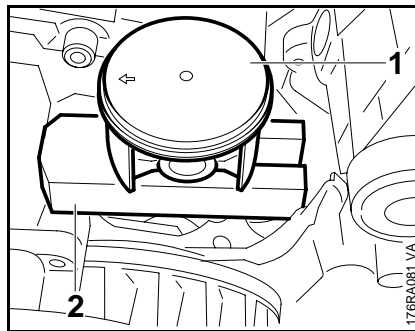

- Coat the piston and piston rings with oil, then place the piston (1) on the wooden assembly block (2) 1108 893 4800.

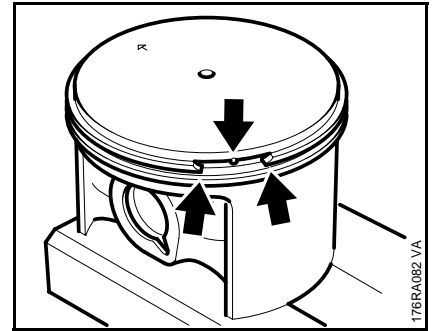

- Align the piston rings: the bevelled radii at the join must engage the fixing pin in the ring groove.

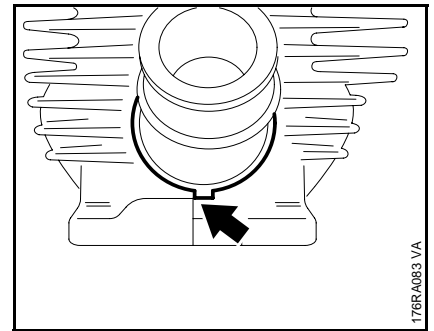

- Push the manifold onto the intake port.
- Note the installed position (arrow).

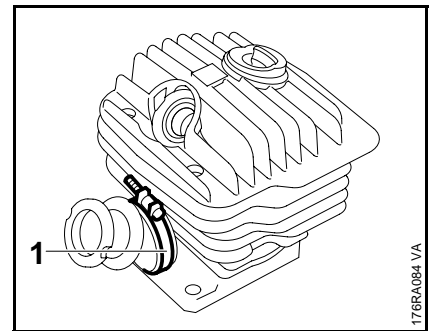

- Fit the hose clamp (1) with the screw head on the right.
- Tighten down the clamp so that it closes against the spacer sleeve.

On clamps with spacer sleeve, tighten the screw until the gap between the two ends of the clamp is 5 to 6 mm (0.17 to 0,24 in).

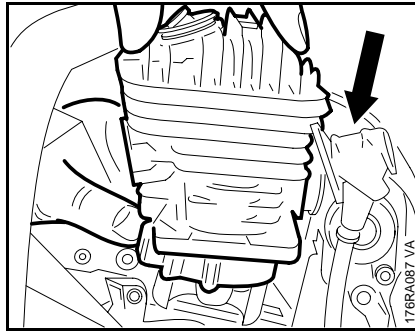

- Carefully slide the cylinder over the piston, the clamping strap moves downwards at the same time.
- Remove the clamping strap and wooden assembly block.

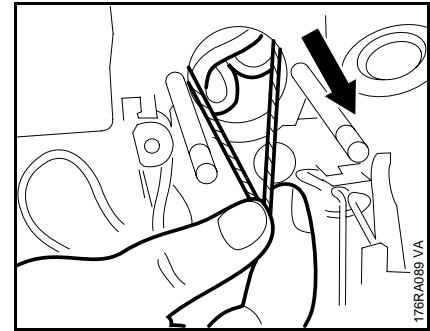

- Pull the ends of the string outward.

The manifold flange is pulled through the tank housing intake opening without damaging the manifold.

- Check that flange is properly seated in the tank housing.

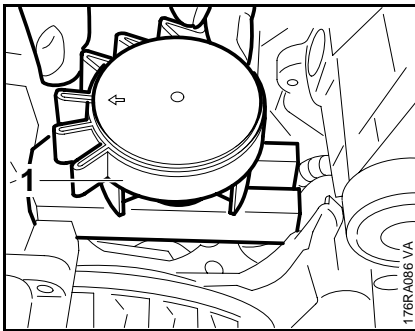

- Use the clamping strap (1) 0000 893 2600 to compress the rings around the piston.
- Check correct installed position of rings once again.
- Lubricate the inside of the cylinder with oil and position it in accordance with its subsequent installed position  
- **ensure it does not break.**

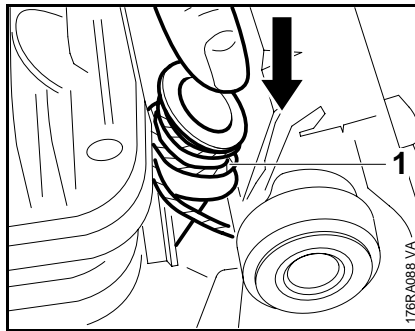

- To pull the manifold flange through the intake opening in the tank housing, wind a piece of string (1) (about 15 cm (5.90 in) long) around the back of the flange and pass the ends of the string through the intake opening.
- Press the manifold down.

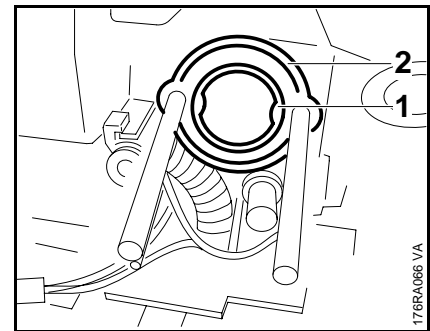

- Press the sleeve (1) into the manifold.
- Fit the washer (2) on the stud bolts.

## 6.6 Piston Rings

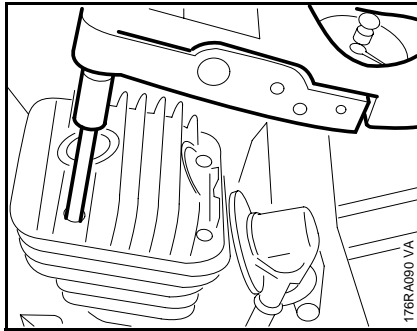

- Line up the cylinder and cylinder gasket.
- Fit the cylinder base screws and tighten them down in an alternate pattern – 3.5

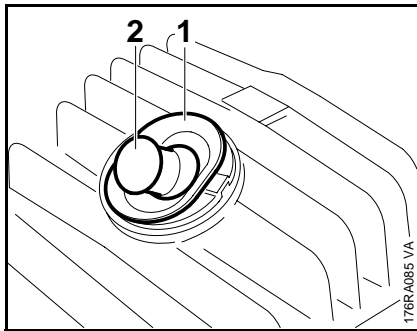

- Screw home the decompression valve (2) if fitted and tighten it down firmly – 3.5
- Fit the cover (1).

Reassemble all other parts in the reverse sequence.

- Remove the piston – 6.5.1
- Remove rings from piston.

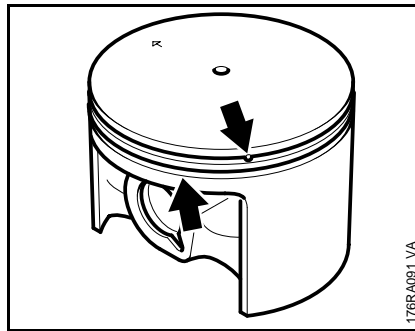

- Use a piece of old piston ring to scrape the grooves clean.

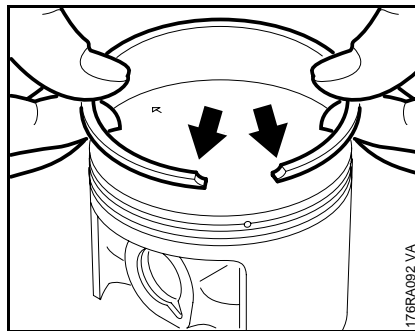

- Install the new piston rings in the grooves so that the radii at the ends of the rings (arrows) face upward.
- Install the piston – 6.5.2

## 6.7 Crankcase

### 6.7.1 Removing the crankshaft

- Remove the chain catcher – 5.2
- Remove the brake band – 5.4.2
- Remove the flywheel – 7.3
- Remove the cylinder – 6.5.1
- Drain the oil tank.
- Drain the fuel tank.

Dispose of fuels and lubricants properly in accordance with environmental requirements.

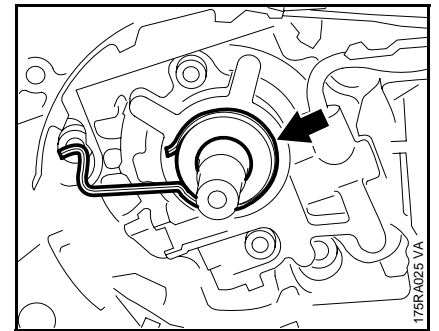

- Pull the worm with drive spring (arrow) out of the oil pump and off the crankshaft stub.

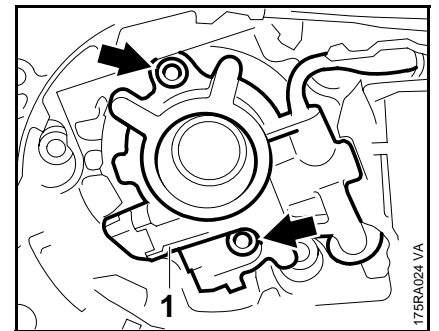

- Take out the screws (arrows).
- Remove the oil pump (1).

- Remove the piston – 6.5.2
- Remove the ignition module – 7.1.2
- Remove the oil seals – 6.3
- Remove the generator on machines with handle heating – 14.5

- Remove the screw from the bottom annular buffer on the fan side – 12.8
- Remove the crankcase from the tank housing.
- Remove the oil seals – 6.3

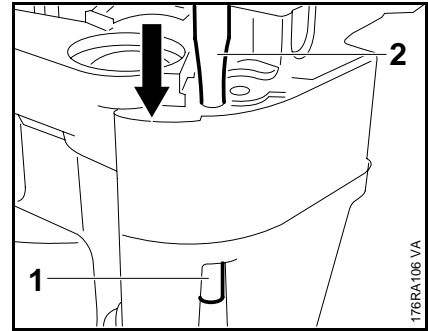

- Drive the straight pin (1) on the chain tensioner side out of the two crankcase halves with a size 5 mm (1.97 in) drift (2).

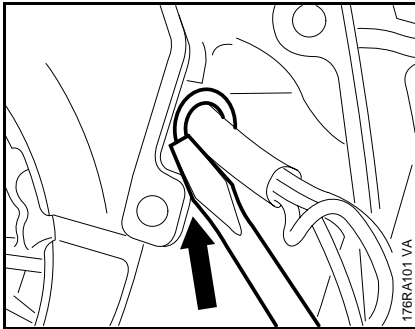

- Press the grommet out of the housing.
- Pull the short-circuit wire and ground wire out of the housing.

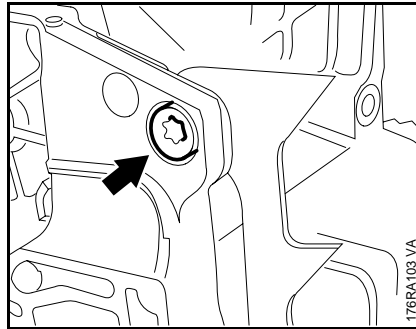

- Take out the screw (arrow), steadying the self-locking nut at the same time.
- Remove the spiked bumper.

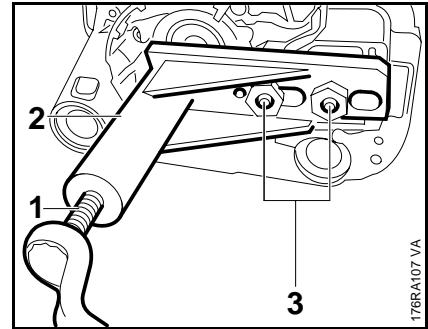

- Back off the spindle (1) in service tool AS 5910 007 2205 all the way.
- Slip service tool AS (2) over the two collar studs.
- Fit the hex nuts (3) (for sprocket cover) and tighten them down by hand.
- Turn the spindle (1) of the service tool clockwise until the crankshaft is pressed out of the ball bearing.

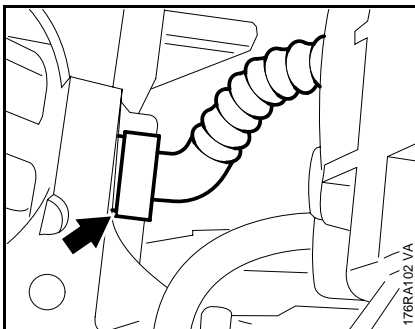

- Unplug the impulse hose from the connector (arrow).
- Remove the screws from the annular buffers on the clutch side – 12.8

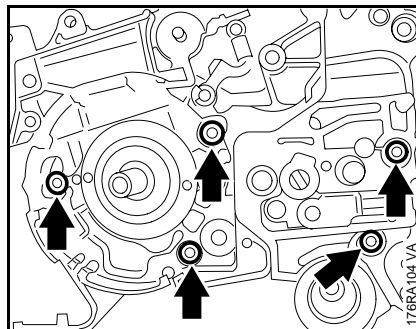

- Remove the screws (arrows) from the two halves of the crankcase.
- Draw the reflector foil off the crankcase.

The two halves of the crankcase separate during this process.

- Remove the service tool AS.

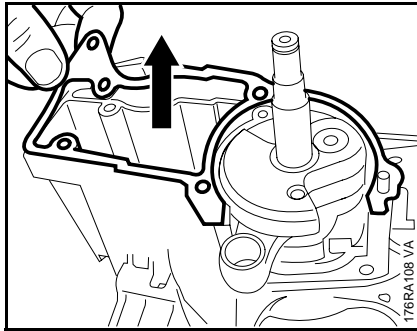

- Remove the gasket from the crankcase.

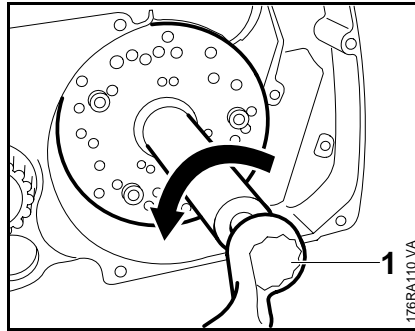

- Turn spindle (1) counter-clockwise until the crankshaft is pushed out of the ball bearing.

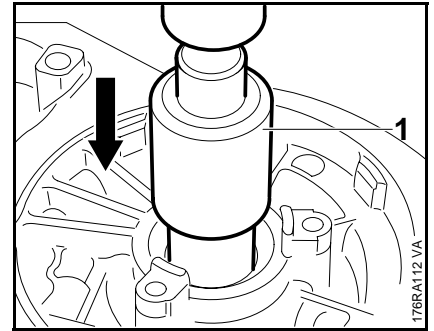

- Drive out the deep groove ball bearing on the flywheel side with press arbor (1) 1120 893 7200.

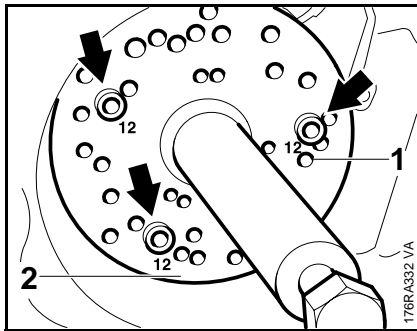

- Unscrew the spindle of service tool ZS (1) 5910 007 2220 (1) a little (left-hand thread)

Make sure the retaining ring at the clutch side has been removed – 6.3

- Position the service tool ZS (1) 5910 007 2220 against the starter side so that the number 12 (2) on the plate is at the bottom.

The cylinder flange faces up.

- Fit three M5x72 screws (arrows) in the holes marked "12" and tighten them down against the drilled plate.

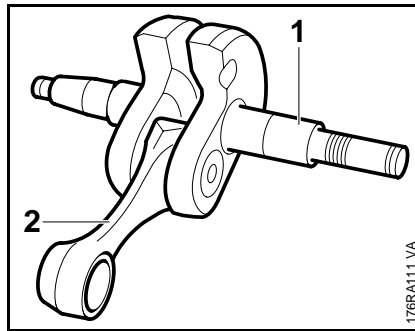

The crankshaft (1), connecting rod (2) and needle bearing form an inseparable unit. It must always be replaced as a complete unit.

When fitting a replacement crankshaft, always install new oil seals and ball bearings.

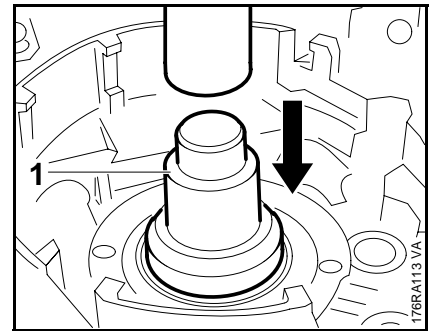

- Drive out the deep groove ball bearing on the clutch side with press arbor (1) 1118 893 7200.
- Inspect both halves of the crankcase for cracks and replace if necessary.

The complete crankcase must be replaced, even if only one half is defective.





Check the condition of all other parts, replace if necessary and transfer to the new crankcase.

If only the ball bearings are replaced, all rubber and polymer components, such as the intake hose, stop buffer and annular buffer can remain in place.

If the crankcase has to be replaced, all the components still fitted must be reused.

## 6.7.2 Installing the crankshaft

This involves the following operations:

- Remove the intake hose with pickup body –  12.7
- Remove the chain tensioner –  5.5
- Unscrew the bar mounting studs –  5.6
- Remove the chain brake –  5.4.2

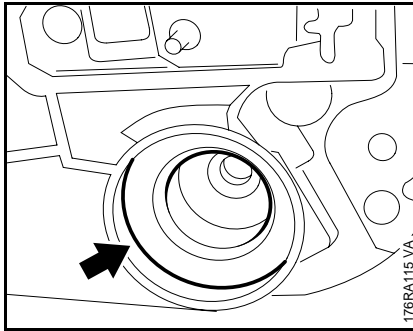

- Press the annular buffer (arrow) out of the crankcase half on the clutch side.

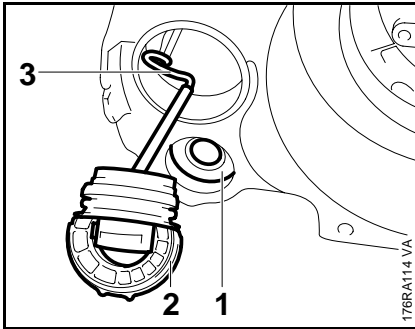



- Press the annular buffer (1) out of the crankcase half on the fan side.
- Unscrew the oil tank cap (2).
- Press the cord (3) out of the mount and remove it with the tank cap.

New crankcases are supplied with preassembled ball bearings and oil seals. It is necessary to stamp the machine's serial number on the crankcase with 2.5 mm (0.98 in) figure stamps.

If only the ball bearings have to be replaced, make sure that the annular / stop buffers, intake hose and oil tank cap have been removed before heating the crankcase.

If the original crankcase is used again, remove all gasket residue and clean the mating surfaces thoroughly to guarantee a perfect seal.

The following additional operations are required when using a new crankcase:

- Install the chain brake –  5.4.3
- Fit the bar mounting studs –  5.6
- Install the chain tensioner –  5.5

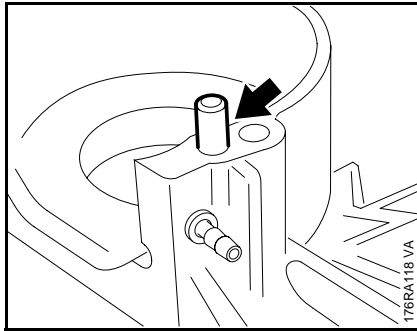

- The straight pin (arrow) must be fitted; if not, it must be driven into the crankcase.
- Heat the fan side of the crankcase to approx. 150 °C (302 °F) around the ball bearing seat.

This operation must be carried out very quickly because the bearing absorbs heat immediately and begins to expand.

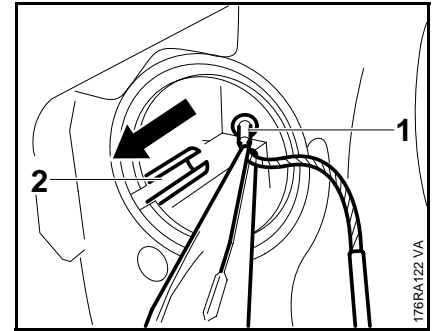

- Fit nipple of tank cap cord (1) in the slot (2) and pull it forwards.

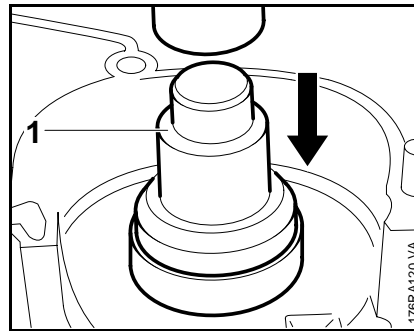

- If it is not possible to heat the clutch side of the crankcase, use press arbor (1) 1118 893 7200 to press home the ball bearing as far as stop.

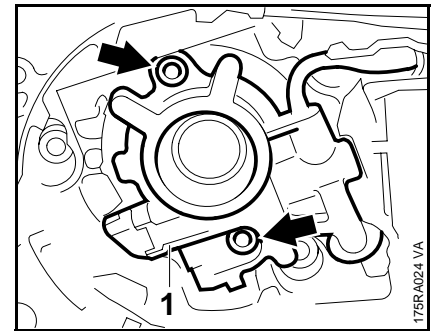

The oil pump must be fitted as stop when installing the deep groove ball bearing.

- Position the oil pump (1).
- Insert the screws (arrows) and tighten them down – 3.5
- Heat the area of the ball bearing on the clutch side of the crankcase to about 150 °C (302 °F).

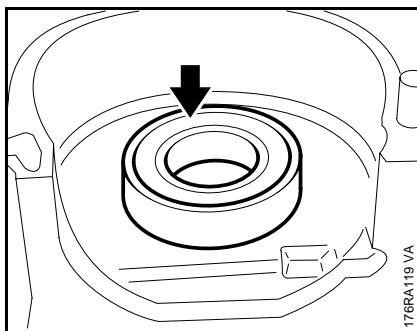

- Press the deep groove ball bearing (arrow) as far as possible into the crankcase by hand with the closed side facing upwards.

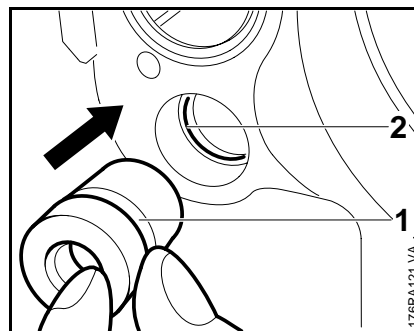

- Let the crankcase cool.
- Press the annular buffer in so that the circumferential groove (1) engages the edge of the crankcase (2).



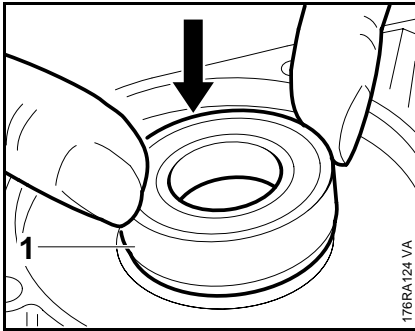

- Press the ball bearing as far as possible towards the oil pump by hand with the shoulder (1) on the inside.

This operation must be carried out very quickly because the bearing absorbs heat immediately and begins to expand.

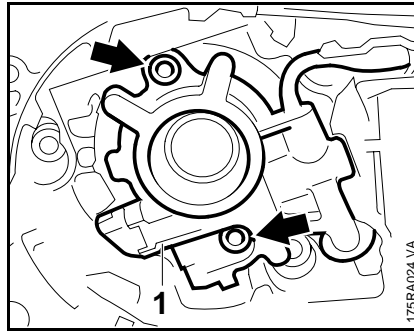

- Take out the screws (arrows).
- Remove the oil pump (1).

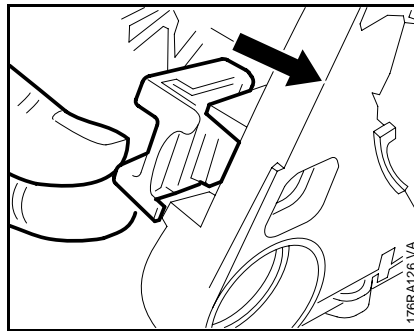

- Wait for crankcase to cool down.
- Press the stop buffer into the guide until the lugs are behind the edge of the housing.

– Install the suction hose – 12.7

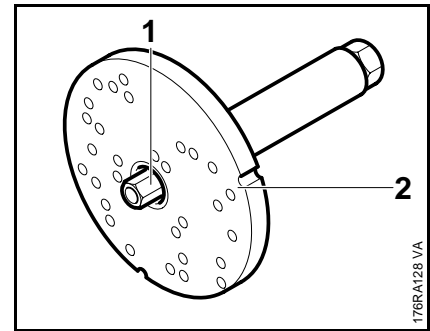

- Screw spindle of service tool ZS (2) 5910 007 2200 fully home and then screw the threaded sleeve (1) 5910 893 2420 onto the spindle.

– Lubricate tapered stub of crankshaft with oil.

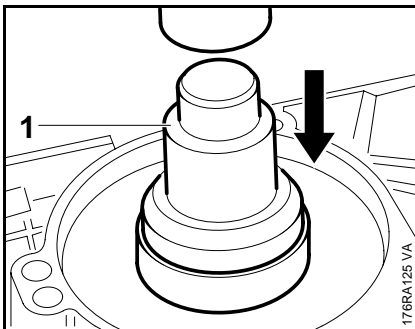

- If it is not possible to heat the clutch side of the crankcase, use press arbor (1) 1118 893 7200 to press home the ball bearing as far as stop.

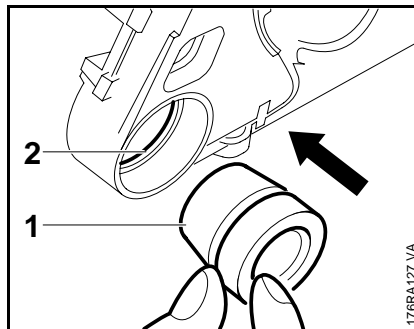

- Press both annular buffers in with the tapered edge inside until the circumferential groove (1) engages the edge of the crankcase (2).

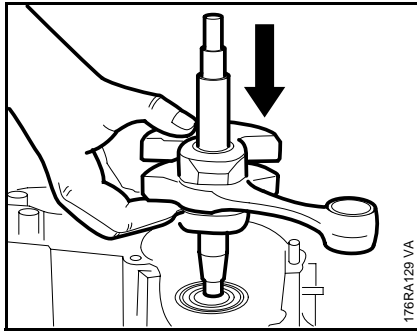

- Place tapered stub of crankshaft in the flywheel side (ball bearing) of the crankcase.

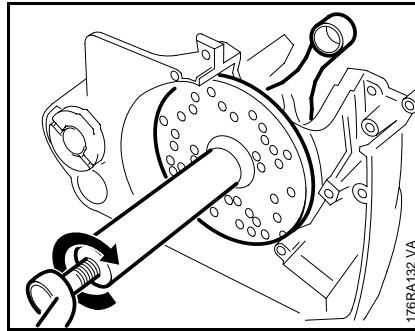

- Turn the spindle clockwise until the crankshaft locates against the ball bearing.

The connecting rod must point toward the cylinder flange while the crankshaft is being installed.

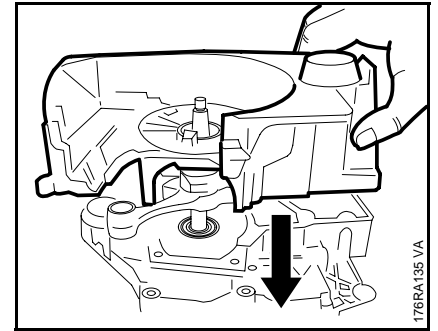

- Lubricate straight stub of crankshaft with oil.
- Fit crankshaft stub in the ball bearing.

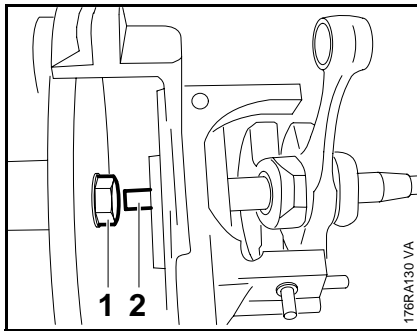

- Screw threaded sleeve (1) to thread (2) on crankshaft stub.

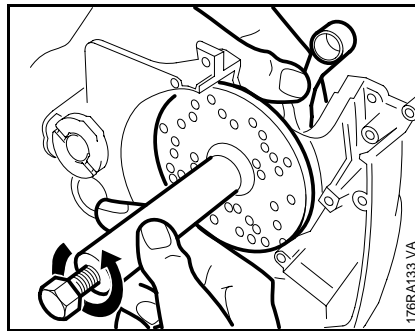

- Hold the crankshaft steady, release the spindle counter-clockwise and then unscrew the service tool, also counter-clockwise.

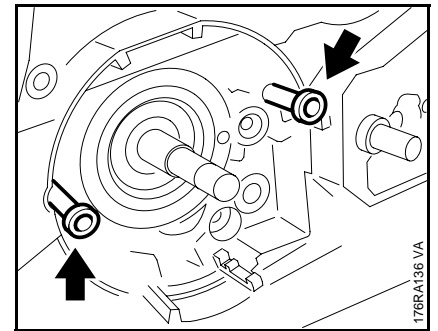

- To prevent the crankcase and gasket twisting, fit M5x72 screws (arrow) in two crankcase holes and tighten them down as far as stop.
- Screw the spindle (counter-clockwise, left-hand thread) fully into the service tool AS 5910 890 2205.

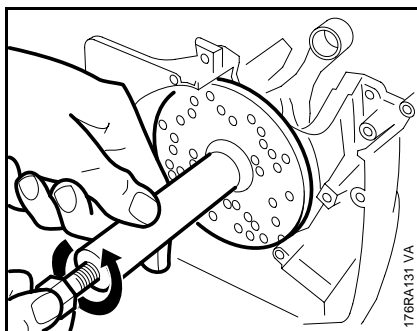

- Hold the spindle steady and rotate the service tool counter-clockwise until the drilled plate butts against the crankcase.

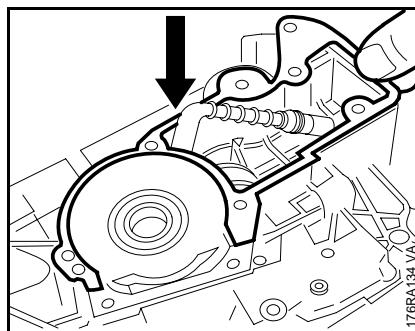

- Place new gasket on clutch side of crankcase.

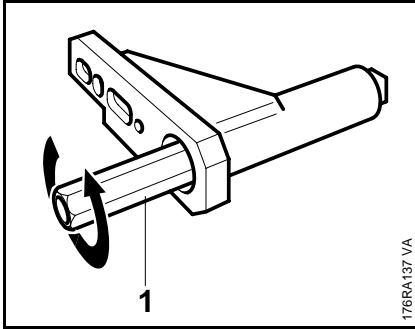

- Screw threaded sleeve (1) 5910 893 2409 of service tool AS 5910 890 2205 onto the spindle as far as stop (left-hand thread).

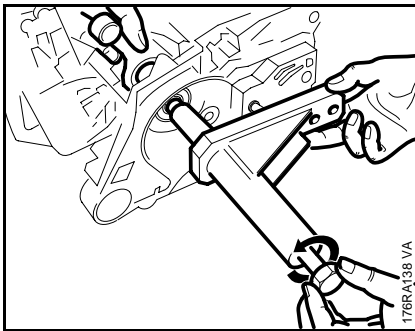

- Push the threaded sleeve over the crankshaft stub.
- Hold the crankshaft steady and rotate the spindle counterclockwise to screw the threaded sleeve onto the crankshaft stub.
- Release the crankshaft. Hold the service tool steady and continue turning the spindle until the tool locates against the guide bar mounting face.
- Fix the nuts for the sprocket cover on the bar mounting studs and screw them down finger-tight.

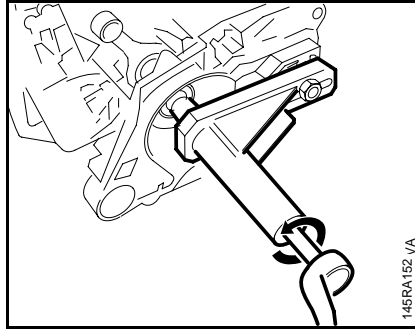

- Turn the spindle counterclockwise until the crankshaft locates against the ball bearing.
- Unscrew the hex nuts.
- Unscrew the spindle clockwise and take away the service tool.
- Take out the two M5x72 screws.

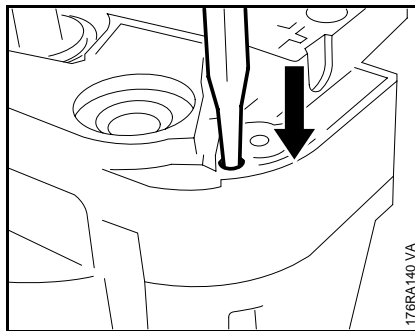

- Drive the straight pin on the chain tensioner side home with a size 5 mm (1.97 in) drift.

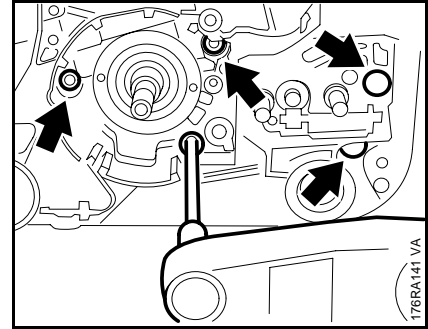

- Fit the screws (arrows) and tighten them down firmly in an alternate pattern – 3.5

Trim away any excess gasket material in the area of the cylinder mounting face.

- Grease the sealing lips of the oil seals – 16.
- Thinly coat the outer circumference of the oil seals with sealant – 16.
- Slide the oil seal with the open side facing the crankcase over the crankshaft stub on the fan side.

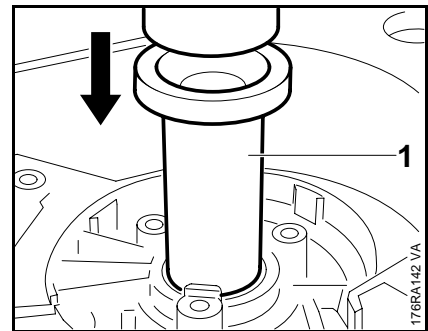

- Press the oil seal home with press sleeve (1) 1128 890 3900.

The surface must be level and free from burr.

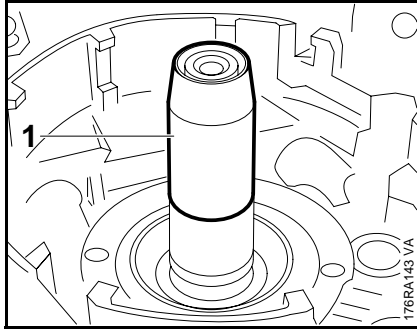

- Push the assembly sleeve 1118 893 2401 (1) over the crankshaft stub on the clutch side.

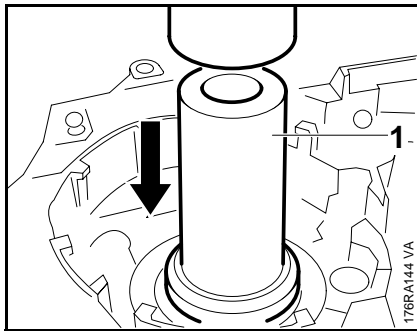

- Slip the oil seal over the assembly sleeve with the open side facing towards the crankcase.
- Press the oil seal home with press sleeve (1) 1118 893 4602.
- Remove the assembly sleeve.
- Turn the crankshaft several times after approx. 1 minute.

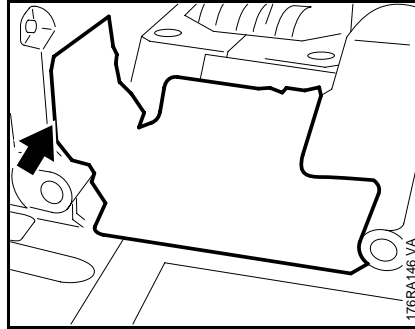

- Clean both halves of the crankcase.
- Affix the reflector foil without creasing so that the foil is raised on the clutch side (arrow).

The following operations are required additionally when replacing the crankcase.

- Install the chain brake – 5.4.3
- Screw in the bar mounting studs – 5.6
- Install the chain tensioner – 5.5

Reassemble all other parts in the reverse sequence.

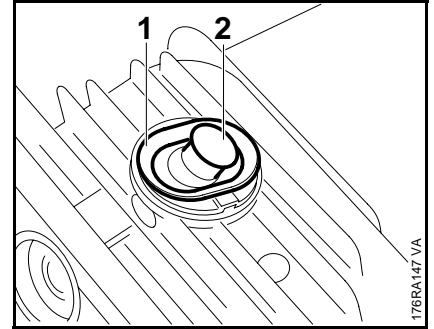

- Remove the shroud – 6.4
- Unscrew the decompression valve (1).
- Install in the reverse sequence (2).

Install in the reverse sequence.

- Fit the decompression valve and tighten it down firmly – 3.5
- Insert the cover (1).
- Fit the shroud – 6.4

## 7. Ignition System

Exercise extreme caution when troubleshooting or carrying out maintenance and repair work on the ignition system. The high voltages that occur can cause serious or even fatal accidents!

Troubleshooting on the ignition system should always begin at the spark plug –  4.4

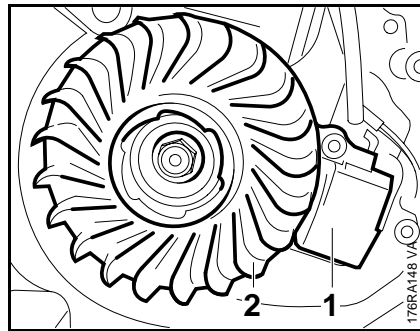

The electronic ignition system basically consists of an ignition module (1) and flywheel (2).

## 7.1 Ignition Module

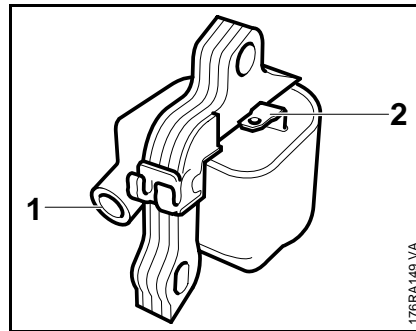

The ignition module accommodates all the components required to control ignition timing. There are two electrical connections on the coil body:

- High voltage output (1) for ignition lead
- Connector tag (2) for short circuit wire



Testing in the workshop is limited to a spark test. A new ignition module must be installed if no ignition spark is obtained (after checking that wiring and stop switch are in good condition).

## 7.1.1 Ignition Timing

Ignition timing is fixed and cannot be adjusted during repair work.

Since there is no mechanical wear in these systems, ignition timing cannot get out of adjustment.

## 7.1.2 Removing and Installing

- Remove the shroud –  6.4
- Remove the fan housing with rewind starter –  8.2

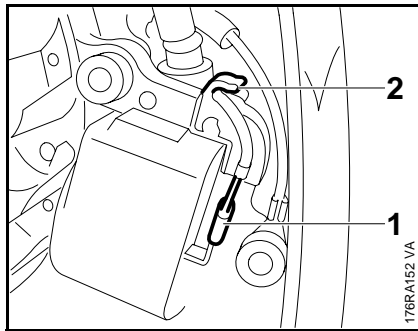

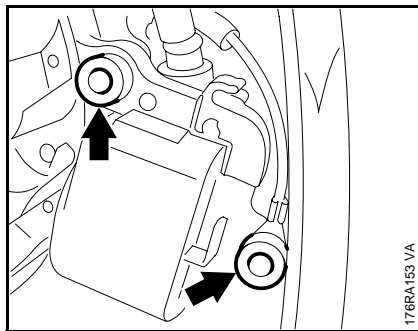

- Pull the short-circuit wire (1) off the ignition module and pry it out of the retainer (2).

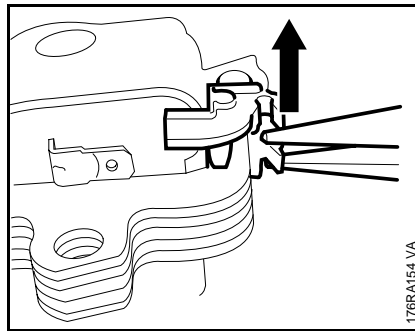

- Take out the screws (arrows).
- Remove the ignition module.

If the ignition lead or spark plug boot is damaged, install new parts –  7.2



- Press the lugs of the retainer outwards if necessary.
- Remove the retainer.
- Connect the ignition lead if necessary before proceeding with installation –  7.2

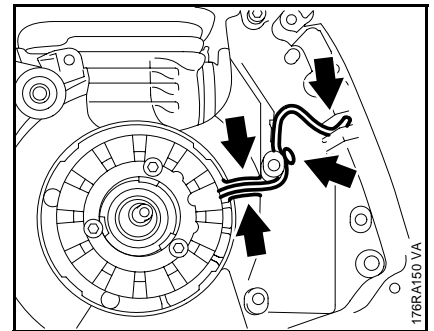

- On machines with handle heating, route the wire through the retainers (arrows).

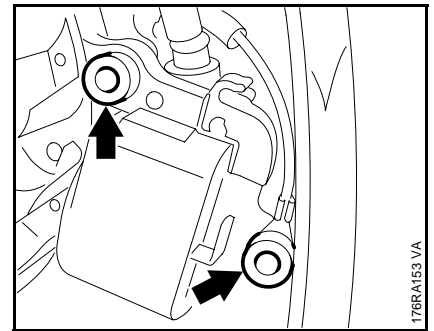

- Install the ignition module.
- On machines with handle heating, the plug connection from the generator must be routed under the ignition module.
- Coat the screw threads with Loctite 242 –  16.
- Fit the ground wire under the right-hand screw of the ignition module.
- Tighten down the screws moderately (arrows).

### 7.1.3 Testing the ignition system

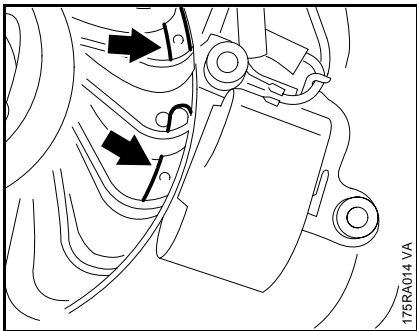

- Turn the flywheel until the two bumps (arrows) are aligned with the ignition module.

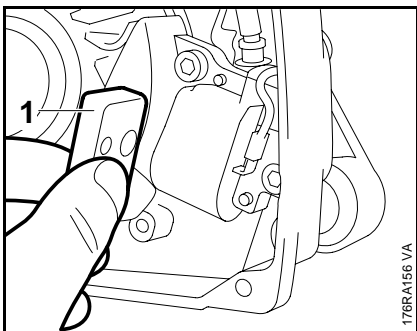

- Slide the setting gauge (1) 1111 890 6400 between the arms of the ignition module and the raised edge of the flywheel.
- Press the ignition module against the setting gauge.
- Tighten down the screws of the ignition module – 3.5
- Connect the short-circuit wire.

Reassemble all other parts in the reverse sequence.

Use the ZAT 4 ignition system tester 5910 850 4503 or ZAT 3 ignition system tester 5910 850 4520 to test the ignition system.

The ignition test refers only to a spark test, not to ignition timing!

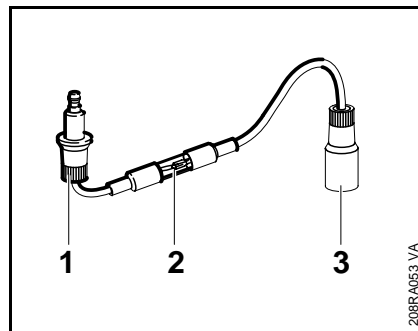

#### Using the ZAT 4 ignition tester 5910 850 4503

- Before starting the test, install a new spark plug in the cylinder and tighten it down firmly – 3.5
- Unplug the boot from the spark plug and connect it to the input terminal (1). Push the tester's output terminal (3) onto the spark plug.
- Crank the engine quickly with the rewind starter (min. 1,000 rpm) and check spark in the tester's window (2).

#### Warning!

The engine may start and accelerate during the test!

If a spark is visible, the ignition system is in order. If no spark is visible in the window (2), check the ignition system with the aid of the troubleshooting chart – 7.6.

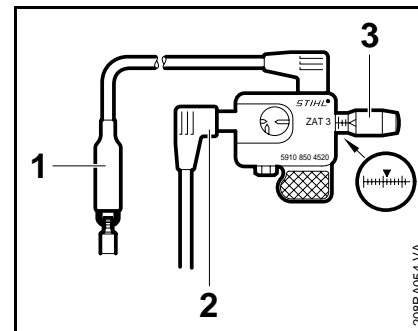

#### Using ZAT 3 ignition tester 5910 850 4520

The ZAT 3 ignition tester 5910 850 4520 must be used to test the auxiliary spark gap

- Before starting the test, screw a new spark plug in the cylinder and tighten it down firmly – 3.5
- Unplug the boot from the spark plug in the engine and connect it to the terminal (2).
- Attach the ground terminal (1) to the spark plug.
- Use adjusting knob (3) to set the spark gap to 2 mm (0.79 in).

## 7.2 Ignition Lead / Spark Plug Boot

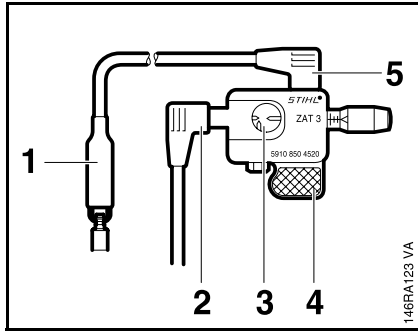

While using the ZAT 3, hold it only by the handle (4) or position it in a safe place. Keep fingers or other parts of your body at least 1 cm away from the spark window (3), high voltage connection (2), ground connection (5) and the ground terminal (1).

### Warning!

High voltage – risk of electrocution.

- Crank the engine quickly with the rewind starter (min. 1,000 rpm) and check sparkover in the tester's window (3).

### Warning!

The engine may start and accelerate during the test.

If a spark is visible, the ignition system is in order.

If no spark is visible in the window (3), check the ignition system with the aid of the troubleshooting chart – 7.6.

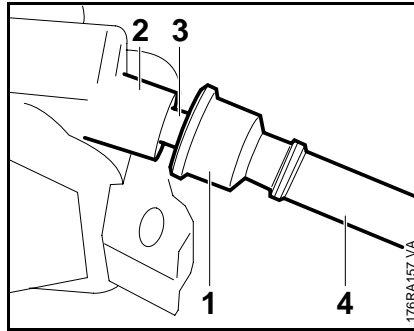

- Remove the ignition module – 7.1.2
- Pull the grommet (1) off the high voltage output (2).
- Unscrew the ignition lead (3) from the high-voltage output.
- Remove the grommet and insulating tube (4) from the ignition lead.

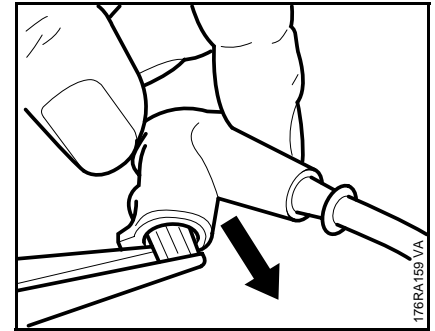

- Use suitable pliers to pull the leg spring out of the spark plug boot.
- Unhook the leg spring from the ignition lead.
- Pull the boot off the ignition lead.
- Cut new ignition lead to a length of 150 mm (59.06 in).
- Coat the end of the ignition lead (approx. 20 mm (7.87 in) with oil.
- Push the boot onto the ignition lead.
- Pull the ignition lead out of the boot with pliers.
- Use a pointed tool to pierce the center of the ignition lead's insulation, about 15 mm (5.91 in) from the end of the lead.

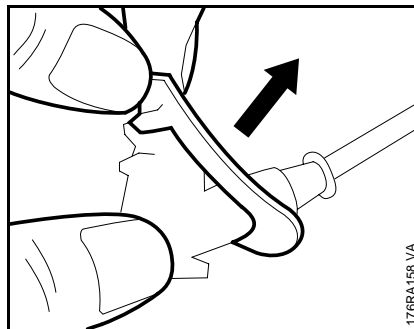

- Pull the cover off the spark plug boot.

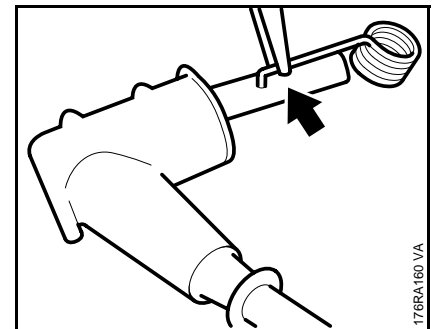

- Pinch the hook of the leg spring into the center of the lead (arrow).



### 7.3 Flywheel

#### 7.3.1 Removal

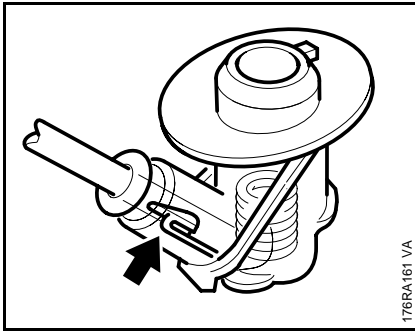

- Pull the ignition lead back until the leg spring locates properly inside the spark plug boot.
- Fit the cover over the spark plug boot.

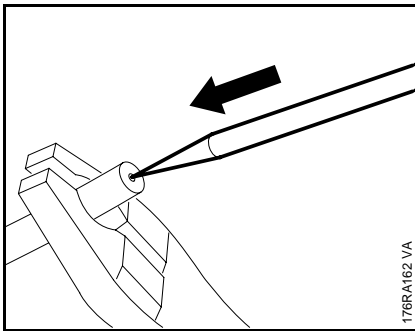

- Use a pointed tool to pierce the center of the other end of the ignition lead.
- Slip the insulating tube and grommet over the ignition lead.
- Pack the high voltage output with STIHL multipurpose grease – 16.

Do not use either graphite grease or silicone insulating paste.

- Screw the ignition lead into the ignition module.
- Push the grommet over the high voltage output.
- Install the ignition module – 7.1.2

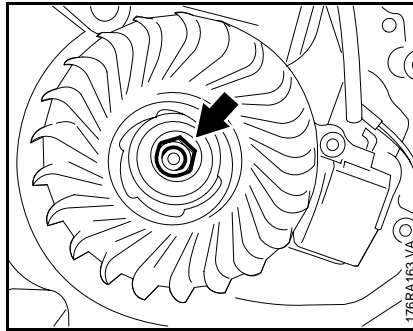

- Remove the fan housing with rewind starter – 8.2
- Block the piston with the locking strip – 5.3
- Unscrew the flywheel nut (arrow).

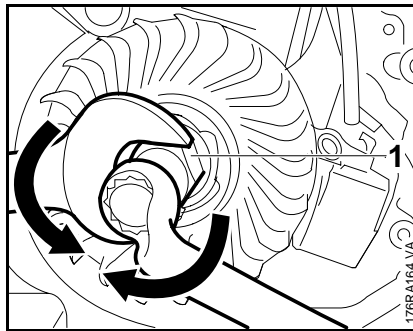

- Screw the puller (1) 1110 890 4500 into the flywheel.
- Screw home thrust bolt until the flywheel is released.

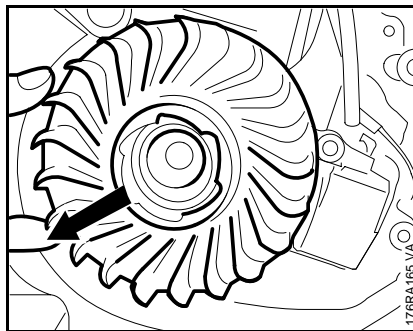



- Pull off the flywheel.
- Remove the puller from the flywheel.

There must not be any cracks or other signs of damage in the flywheel and magnet poles, otherwise the flywheel must be replaced.

### 7.3.2 Installation

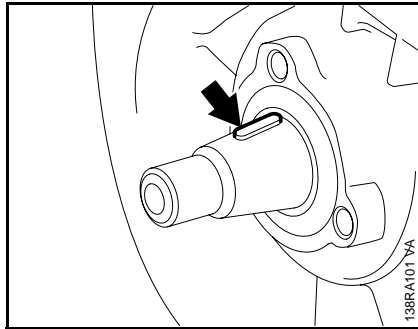
- Degrease the crankshaft stub and bore of the flywheel hub with standard solvent-based degreasant not containing any chlorinated or halogenated hydrocarbons –  16.



- Ensure that the key (arrow) is properly seated.
- Fit the flywheel.
- Screw on the collar nut and tighten it down –  3.5

Reassemble remaining parts in the reverse order.

### 7.4 Stop switch

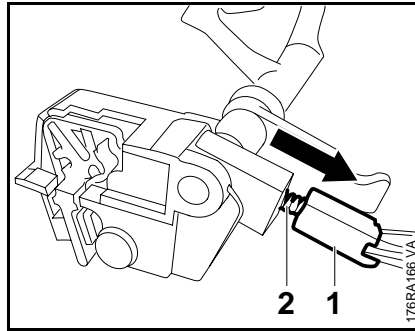

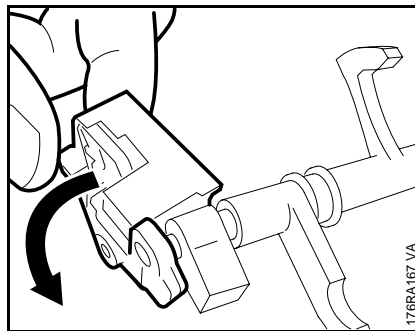

- Remove the switch shaft –  10.1
- Turn the switch housing until the slide control is clear.
- Pull out the slide control (1) and compression spring (2).



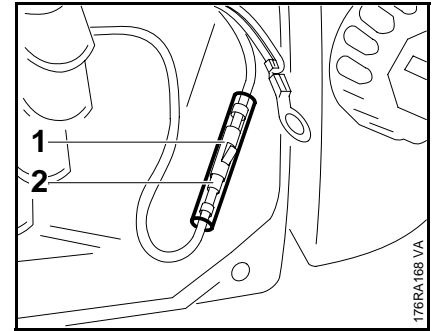

- Carefully push the switch housing aside and remove it.
- When fitting the slide control, push it inwards until it clicks into place.

### 7.5 Wiring harness

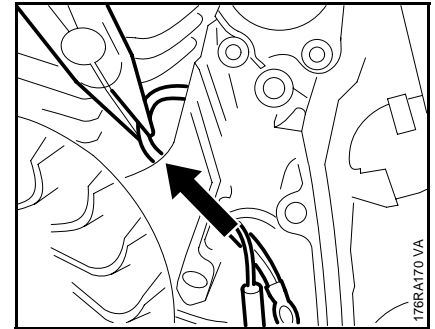

- Remove the ignition module –  7.1
- On machines with handle heating, pull the male connector (1) out of the female connector (2).



- Pull the wiring sideways out of the tank housing
- Remove the carburetor –  12.2.1

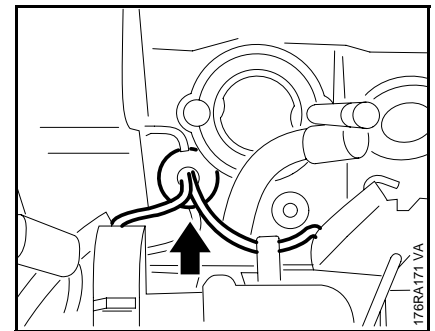

- Remove the grommet and wiring from the tank housing.

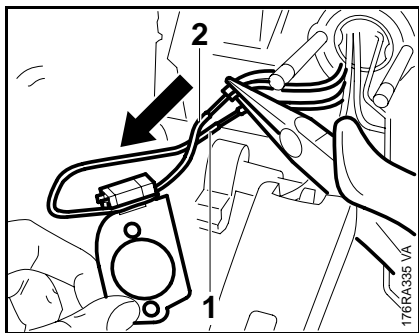

- On machines with carburetor heating, push the protective tubes back over the connections and unplug the leads (1+2).
- Remove the interlock lever – 10.2
- Remove the protective tubing over the plug connection on the lead from the generator to the handle heat shield.

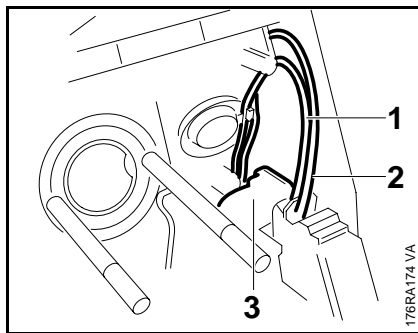

- Unplug the terminal sockets of the short-circuit wire (1) and ground wire (2) from the contact springs.
- On machines with handle heating, remove the heater switch (3) – 14.2
- Remove the wiring harness.

Reassemble in the reverse sequence.

- After insert the wiring harness, press the leads properly into the retainers
- Insert the grommets correctly in the openings in the tank housing.

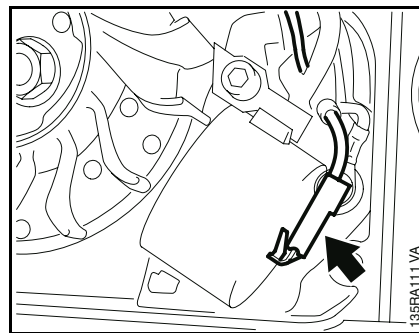

If the spark plug and ignition lead with spark plug boot are in order, check the resistance of the short circuit wire, ground wire and contact spring.

- Unplug the short-circuit wire (arrow).
- Connect the ohmmeter to ground and the short circuit wire.

- Set Master Control lever to "0"

The measured resistance must be around 0 ohm. If the value is distinctly higher, there is a break in the wire somewhere and the wire or slide control must be replaced.

- Set Master Control lever to "I"

The measured value must be infinitely large, otherwise replace the slide control.

The following tests must be performed if faults cannot be found:

- Examine the flywheel for signs of damage – 7.3
- Check the air gap between flywheel and ignition module – 7.3.2

Replace the ignition module if a fault still cannot be located – 7.1.2

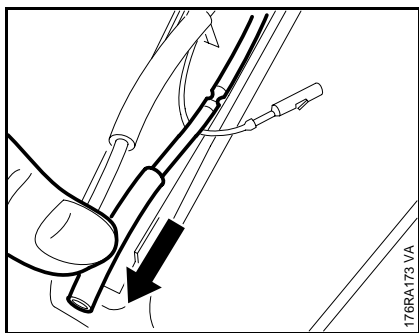

- Unplug both lines and remove the protective tubing.
- Pull the wire out of the grommet.

## 7.6 Ignition System Troubleshooting

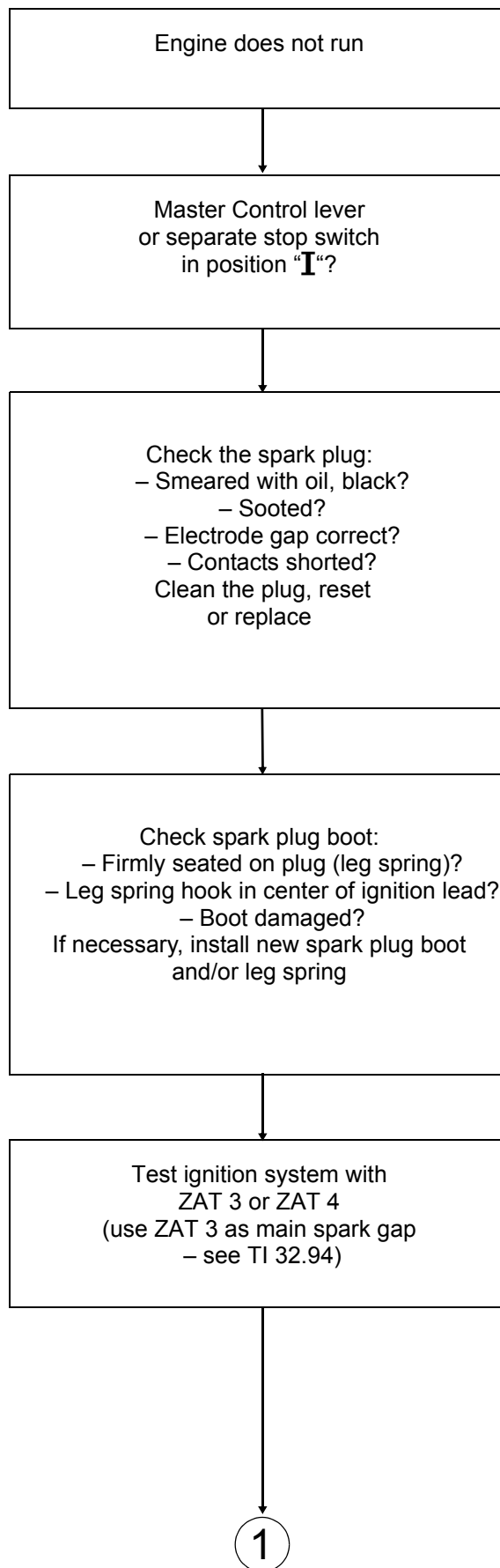

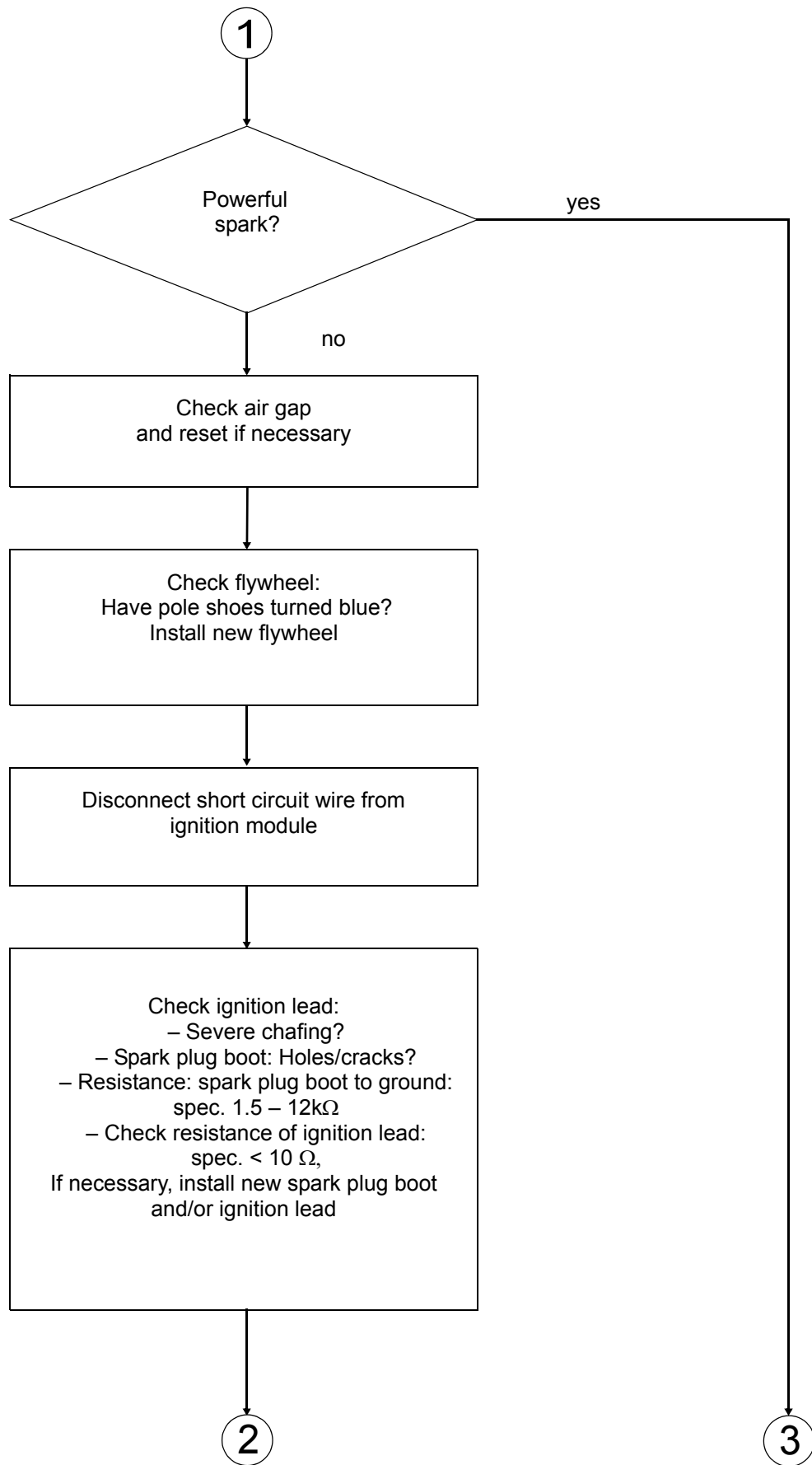

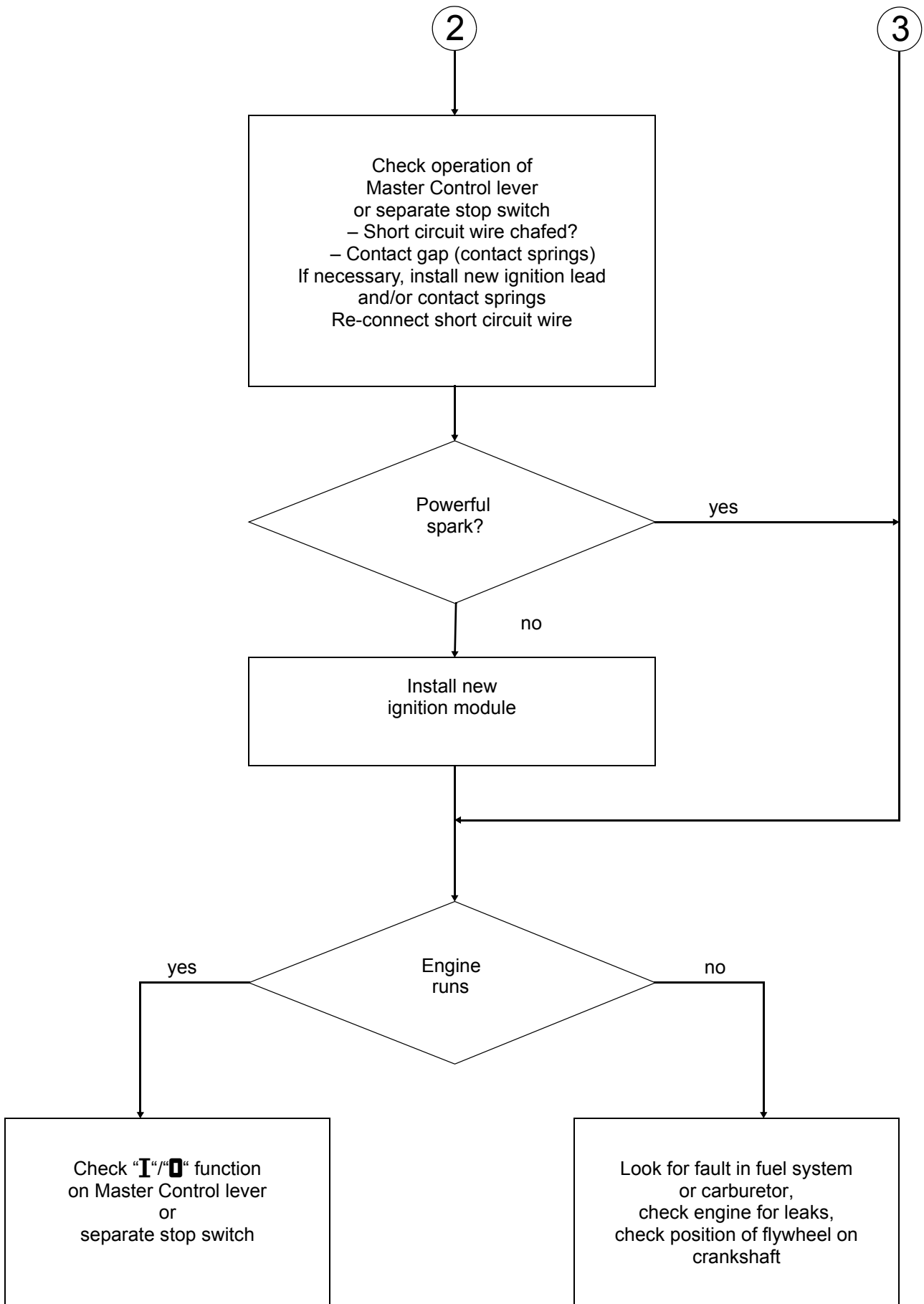

## 8. Rewind Starter

### 8.1 General

If the action of the starter rope becomes very stiff and the rope rewinds very slowly or not completely, it can be assumed that the starter mechanism is in order but plugged with dirt. At very low outside temperatures, the lubricating oil on the rewind spring may thicken and cause the spring windings to stick together, impairing the function of the starter mechanism. In such a case it is sufficient to apply a few drops of a standard solvent-based degreasant (containing no chlorinated or halogenated hydrocarbons) to the rewind spring.

Carefully pull out the starter rope several times and allow it to rewind until its normal smooth action is restored.

If clogged with dirt or pitch, the entire starter mechanism, including the rewind spring, must be removed and disassembled. Take particular care when removing the spring.

Clean all components –  16.

Before installing, lubricate the rewind spring and starter post with STIHL special lubricant –  16.

## 8.2 Removing and Installing

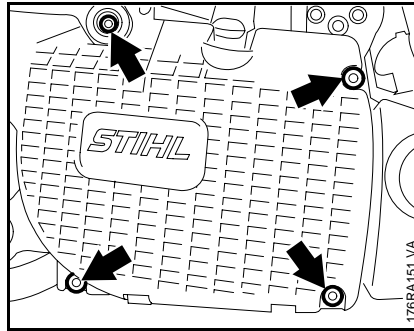

- Carefully remove the screws (arrows) from the fan housing with starter mechanism.
- Remove the fan housing.

Reassemble in the reverse sequence.

The hand guard is secured to the fan housing and crankcase with the IS-M5x35 screw.

- Tighten down the screws –  3.5

## 8.3 Pawls

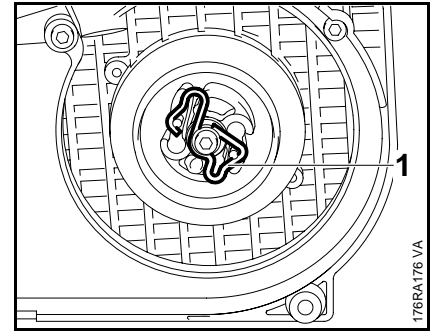

- Remove the fan housing with rewind starter –  8.2
- Carefully ease the spring (1) off the starter post.

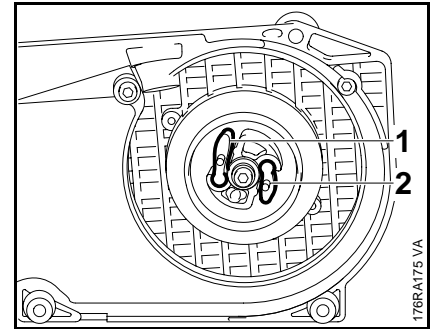

- Pull the pawls (1 + 2) out of the rope rotor.
- Lubricate pegs of new pawls with grease –  16.

Reassemble in the reverse sequence.

## 8.4 Rope Rotor

- Remove the fan housing with rewind starter –  8.2

### Relieving tension of rewind spring

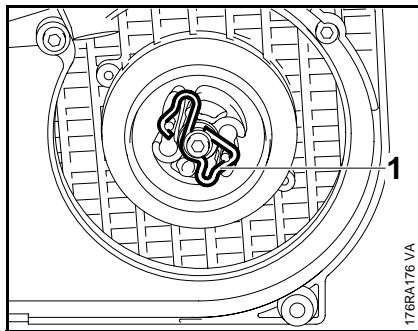

- Pull out the starter rope about 5 cm (1.97 in) and hold the rope rotor steady.
- While still holding the rope rotor steady, take three full turns off the rope rotor.
- Pull out the rope with the starter grip and slowly release the rope rotor.

The system will not be under tension if either the starter rope or rewind spring is broken.



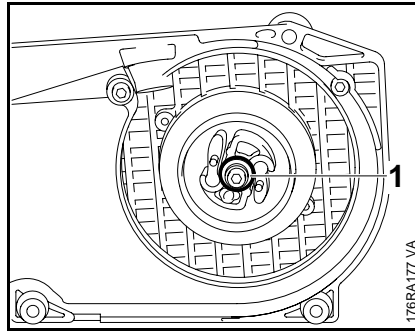

- Carefully ease the spring (1) off the starter post with a screwdriver or pliers.



- Remove the washer (1) from the starter post.
- Remove the pawls –  8.3
- Carefully pull the rope rotor off the starter post.
- Remove the starter rope from the rope rotor –  8.5

Reassemble in the reverse sequence.

- Fit the starter rope –  8.5
- Tension the rewind spring –  8.5.1

## 8.5 Starter rope

- Install the fan housing with starter mechanism –  8.2

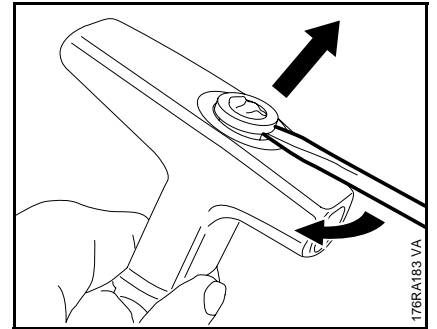

- Pry the nipple of the starter rope out of the starter grip.
- Remove remaining rope from the rope rotor.

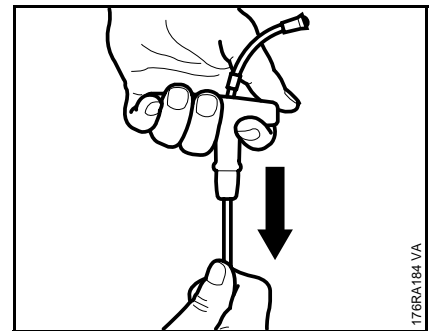

- Thread the new starter rope through the top of the starter grip.
- Remove the rope rotor –  8.4



## 8.5.1 Tensioning

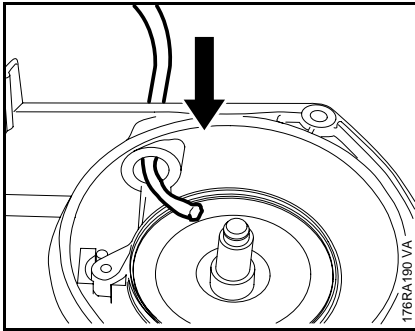

- Thread the other end of the rope, from the outside, through the guide bushing in the fan housing.

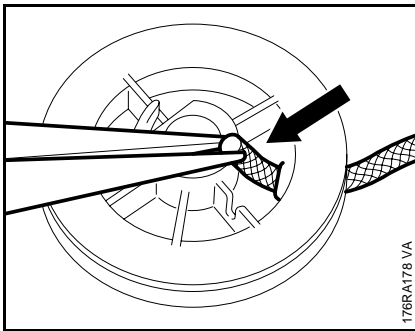

- Thread the new rope through the hole and pull it out.
- Secure the rope with a simple overhand knot and pull it back.
- Install the rope rotor – 8.4

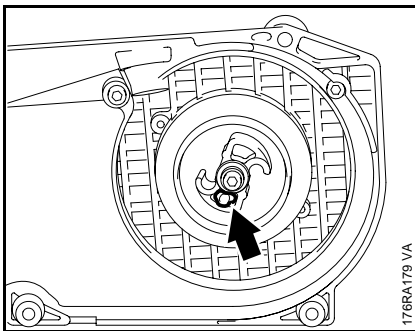

- Push the knot into the recess (arrow).
- Tension the rope rotor – 8.5.1

- Remove the fan housing with rewind starter – 8.2
- Relieve tension of rewind spring – 8.4

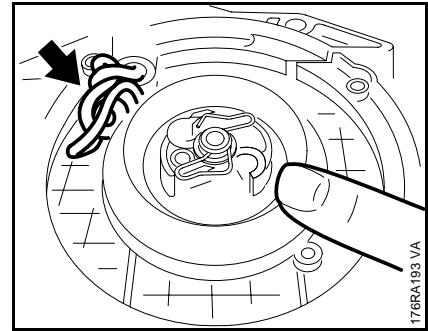

- Hold the rope rotor steady.
- Pull out the rope with the starter grip and straighten it out.
- Hold the starter grip firmly to keep the rope tensioned.
- Let go of the rope rotor and slowly release the starter rope so that it can rewind properly.

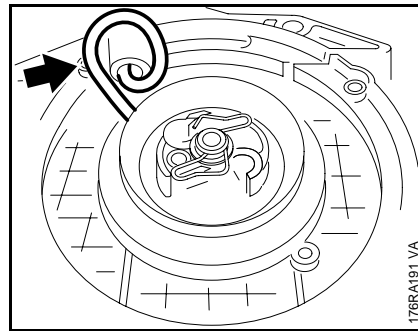

- Make a loop in the starter rope.

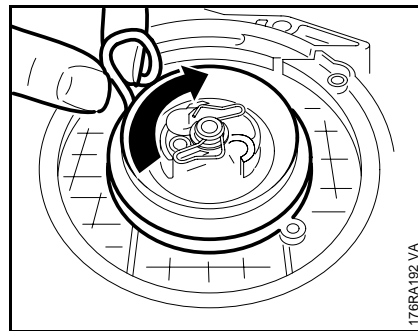

- Grip the rope next to the rotor and use it to turn the rope rotor six times clockwise.

## 8.6 Starter Rope Guide Bushing

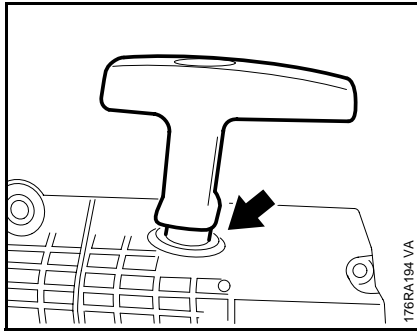

The rewind spring is correctly tensioned when the starter grip sits firmly in the rope guide bushing without drooping to one side. If this is not the case, tension the spring by one additional turn.

When the starter rope is fully extended, it must still be possible to rotate the rope rotor at least another half turn before maximum spring tension is reached. If this is not the case, pull the rope out, hold the rope rotor steady and take off one turn of the rope.

**Do not overtension the rewind spring as this will cause it to break**

- Fit the fan housing with rewind starter – 8.2

Wear on the guide bushing is accelerated by the starter rope being pulled sideways. The wall of the bushing eventually wears through and the bushing becomes loose.

- Remove the starter mechanism – 8.2
- Remove the rope rotor – 8.4

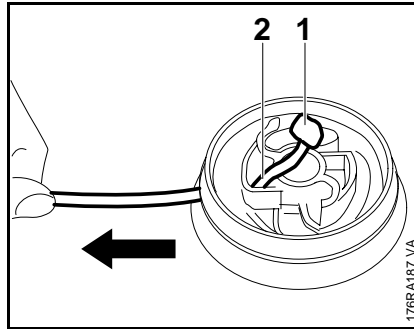

- Pull the knot (1) in the starter rope out of the recess (2) in the rope rotor.
- Undo the knot.
- Pull the starter rope out of the rope rotor and rope guide bushing.
- Use a suitable implement to pry the defective rope guide bushing out of the fan housing with starter mechanism.

### Installing the rope guide bushing

- Install the bushing in the mount in the fan housing with starter mechanism.

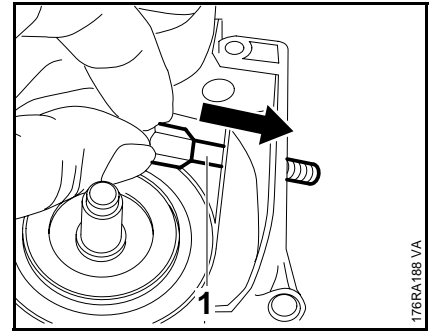

- Insert the screw spindle (1) of the installing tool 0000 890 2201 through the bushing from inside the fan housing.

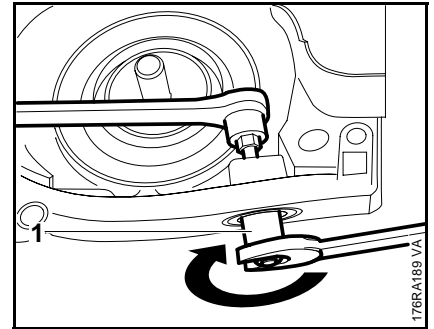

- Fit the thrust sleeve (1), tapered end first, and the hex nut.
- Tighten down the hex nut until the bushing is firmly seated.

The installing tool flares the lower end of the rope bushing.

- Remove the installing tool.
- Fit the starter rope and rope rotor – 8.5

Reassemble all other parts in the reverse sequence.

## 8.7 Replacing the Rewind Spring

Troubleshooting chart –  4.2

The replacement spring comes ready for installation and is secured in a frame.

### Removing

Wear a face shield and work gloves!

- Remove the rope rotor –  8.4

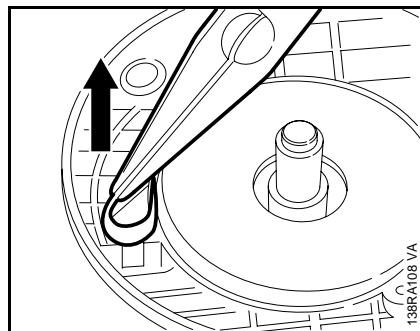

- Use suitable pliers to grip the outer spring loop and lift it up.
- Take the rewind spring out of the fan housing.
- Remove any remaining pieces of spring from the fan housing.

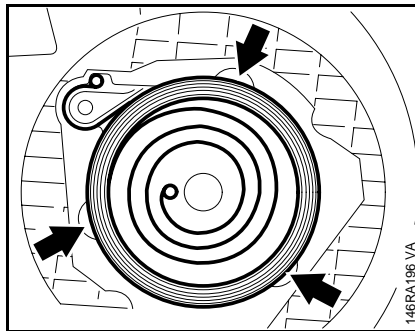

### Installing

- Lubricate the spring with a few drops of STIHL special lubricant before installation –  16.
- Position the replacement spring with frame in the fan housing.

The spring loop must be located over the lug in the fan housing.

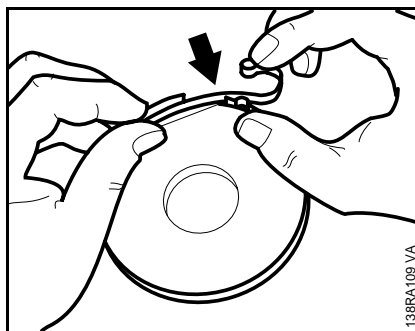

- Position suitable tools on the recesses (arrows) and push the spring into its seat in the fan housing.

If the rewind spring pops out during installation, fit it in the installing tool 1116 893 4800 as follows:



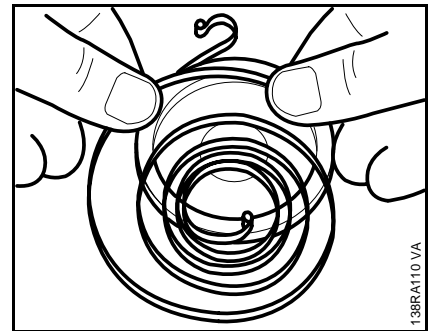

- Position the anchor loop about 25 mm (0.98 in) from the edge of the spring housing.



- Fit the rewind spring in the spring housing in the counterclockwise direction, starting from outside and working inwards.
- Place the spring housing in the fan housing.
- Press the spring loop into the recess in the fan housing at the same time.
- Remove the installing tool.
- Install the rope rotor –  8.4
- Tension the rewind spring –  8.5.1

## 9. AV handle system

The handle and engine housing are connected by vibration-damping annular rubber buffers. Damaged rubber buffers (annular buffers) must be replaced.

- Remove the air filter –  12.2.1
- Remove the shroud –  6.4

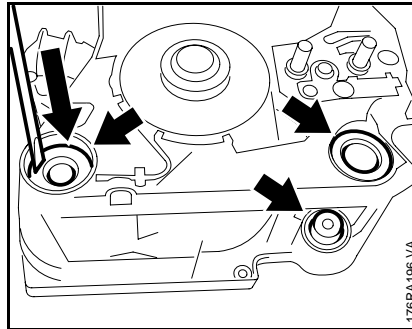

- Pry the annular buffers (arrows) out of the two halves of the crankcase.

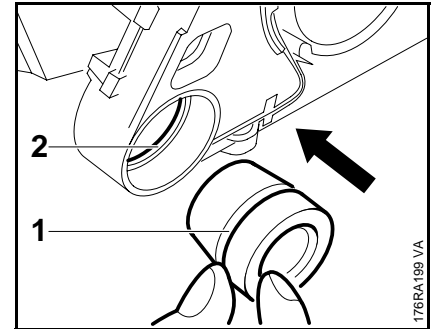

- Press the annular buffer on the clutch side in from the outside until the circumferential groove (1) engages the housing rib (2).

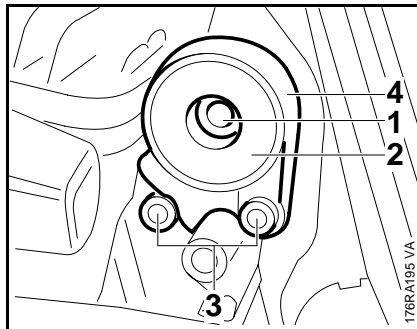

- Take out the screw (1).
- Remove the sleeve (2).
- Take out the screws (3).
- Remove the annular buffer (4).

The tank housing must be removed in order to remove the other annular buffers –  12.8

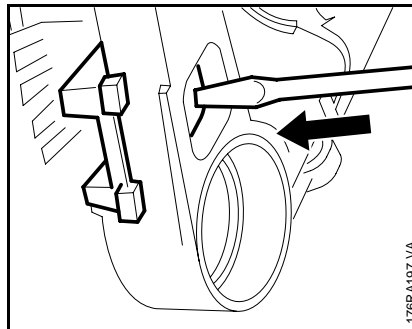

- Drive the stop buffer out of its mount and remove it.

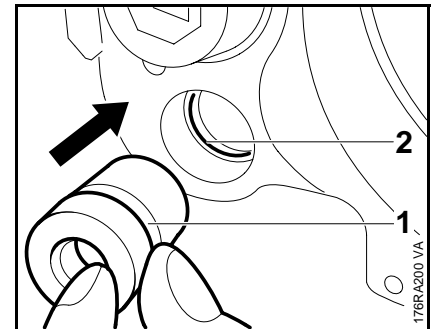

- Press the annular buffer on the starter side in from the outside until the circumferential groove (1) engages the housing rib (2).

Reassemble the other parts in reverse order.

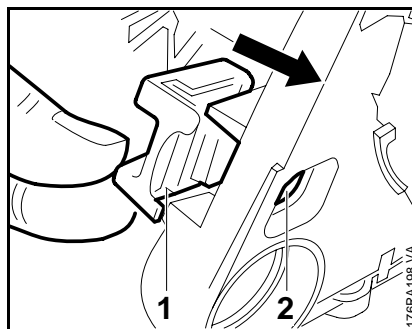

- Press the stop buffer into the guide until the circumferential groove (1) engages the housing rib (2).

## 10. Single lever master control / handle system

### 10.1 Switch shaft

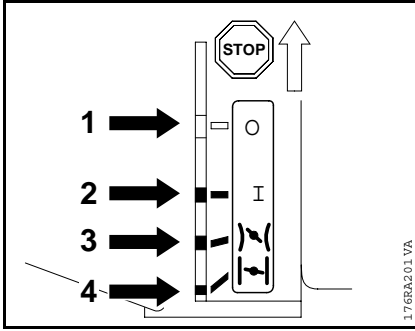

The master control lever moves the switch shaft to select the required function.

The following positions can be selected with the master control lever:

"STOP" (1) closes the short-circuit contact, interrupts ignition.

"RUN" (2) is the normal operating position: the engine is running or may start up.

"START" (3) is the starting throttle position / choke shutter open (warm start).

"CHOKE" (4) is the starting throttle position / choke shutter closed (cold start).

– Disconnect the throttle rod from the carburetor – 12.2.1

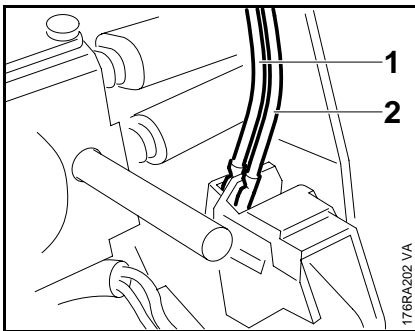

- Unplug the terminal sockets of the short-circuit wire (1) and ground wire (2) from the contact springs.

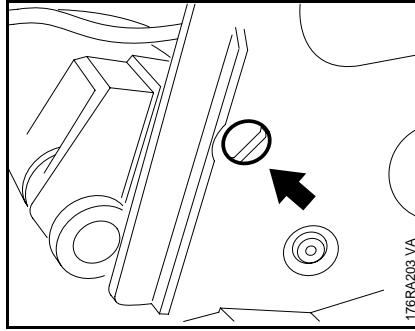

- Remove the screw (arrow) from the switch shaft.

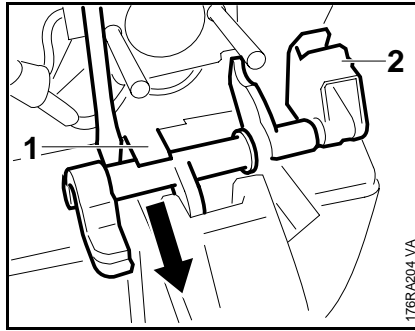

- Carefully ease the switch shaft out of its left-hand mount (1) and pull the switch housing (2) out of the right-hand guide.

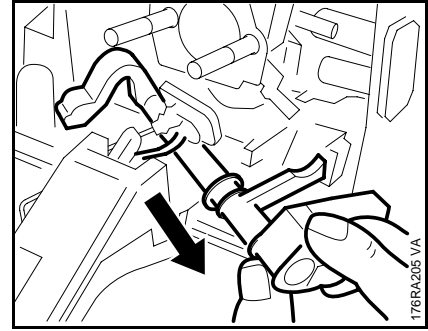

#### Machines with handle heating

- Remove the switch shaft under the leads towards the handle heating element.

Reassemble in the reverse sequence.

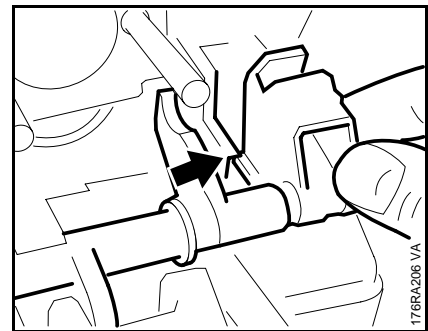

- Fit the switch housing in the guide before pressing the switch shaft into its mount.

Reassemble the remaining parts in reverse order.

## 10.2 Throttle Trigger / Interlock Lever

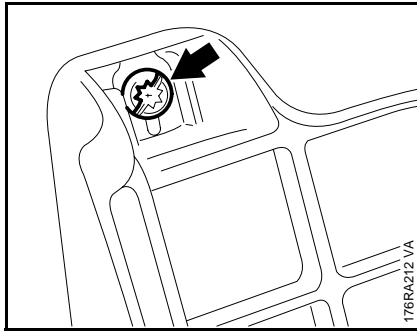

- Remove the filter base – 12.1
- Remove the screw (arrow) underneath the rear handle.
- Remove the handle molding upwards.

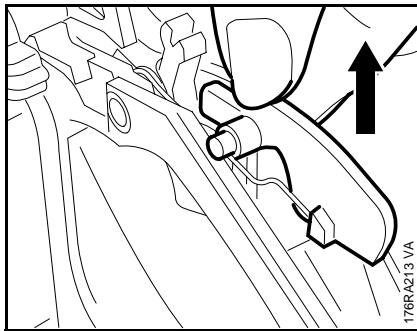

- Move the Master Control to the "RUN" position.
- Remove the interlock lever.

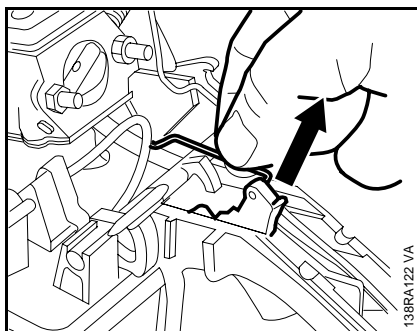

- Pull the throttle rod out of the trigger.

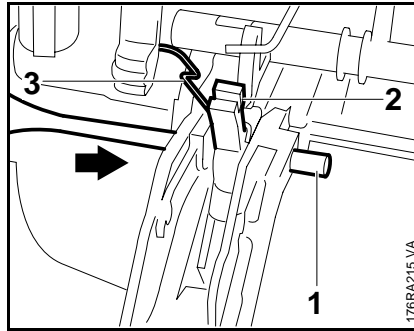

- Use a 5 mm (0.20 in) drift to drive out the pin (1).
- Remove the throttle trigger (2) with torsion spring (3).

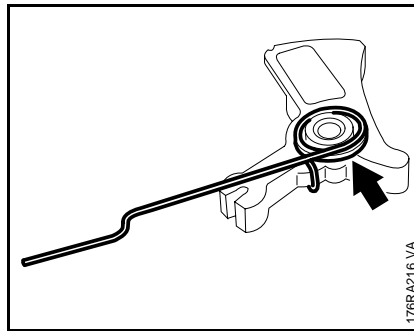

- Remove the torsion spring from the throttle trigger.

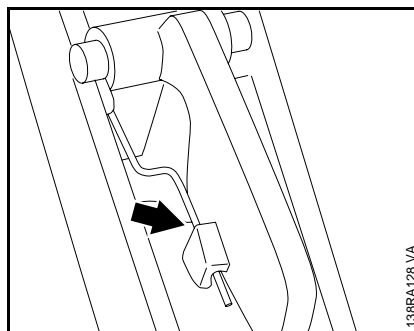

When installing, make sure the torsion spring be under the interlock lever and engage the notch.

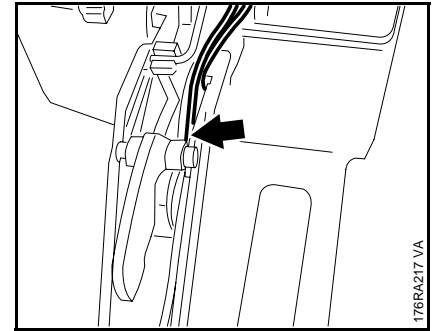

### Machines with handle heating only

- The wires from the heating element must be routed under the interlock lever (arrow) and in the guide.

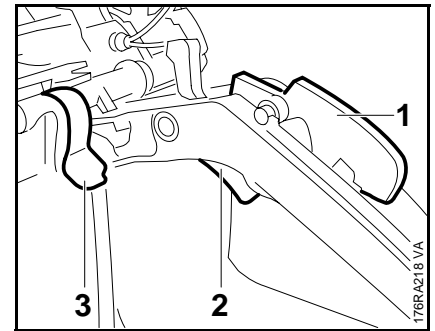

- Press down the interlock lever (1).
- Push the throttle trigger (2) upwards and move the switch lever (3) to "Choke" position.

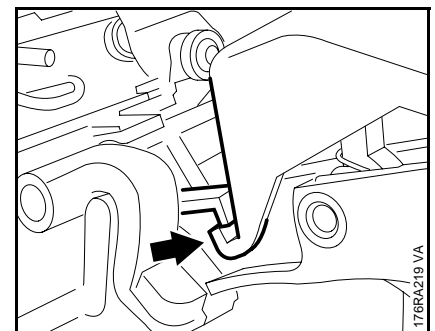

- Position the handle molding so that the lugs (arrow) engage the recess.

## 11. Chain Lubrication

### 11.1 Pickup Body / Suction Hose

Impurities gradually clog the fine pores of the filter with minute particles of dirt. This prevents the oil pump from supplying sufficient oil to the bar and chain. In the event of problems with the oil supply system, first check the oil tank and the pickup body. Clean the oil tank if necessary.

Troubleshooting chart –  4.3

#### Suction hose

- Unscrew the oil tank cap and drain the oil tank.

Collect chain oil in a clean container or dispose of it properly at an approved disposal site.

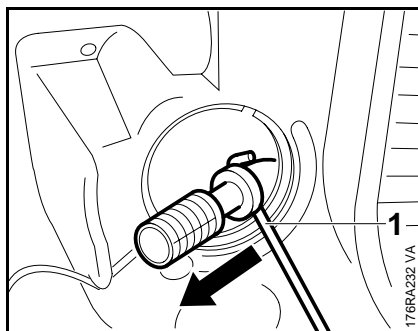

- Use hook (1) 5910 893 8800 to pull the pickup body out of the oil tank.

Do not stretch the oil hose too much during this operation.

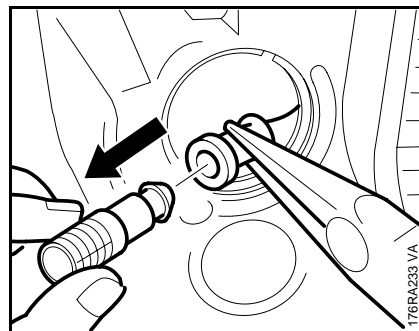

- Pull the pickup body out of the suction hose.

- Fit a new pickup body.
- Flush out the oil tank.

Reassemble in the reverse sequence.

#### Suction hose

- Remove the oil pump –  11.3.1
- Grip the tab of the suction hose with pliers and pull the grommet out of the bore.

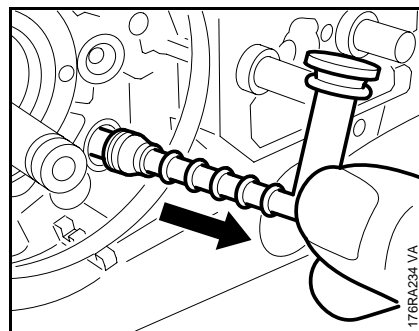

- Pull the suction hose with pickup body out of the crankcase.

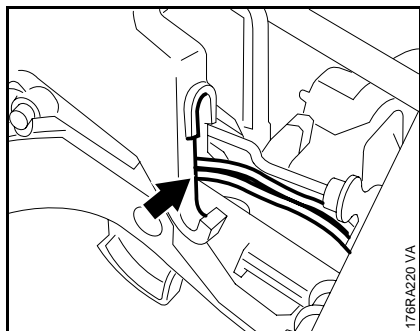

- The wires must be in the guide in the handle moulding.

- Refit the filter base –  12.1

Reassemble all other parts in the reverse sequence.

## 11.2 Valve

### 11.2.1 Cleaning

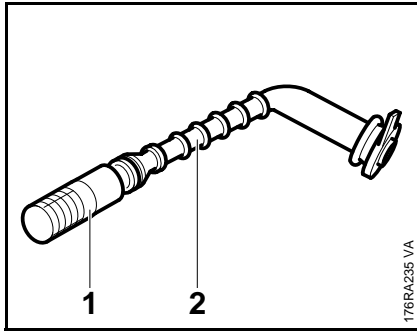

- Pull the pickup body (1) off the suction hose (2).

Reassemble in the reverse sequence.

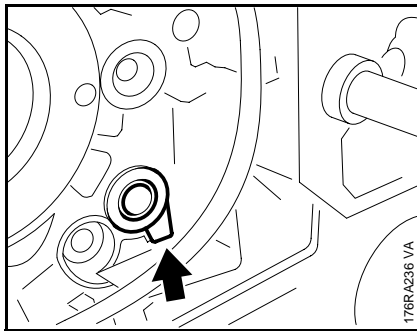

- Insert the suction hose in the crankcase.
- Lubricate grommet with a little oil.
- Use a blunt tool to push the suction hose into the crankcase so that the tab locates in its seat at the bottom right (arrow).

A valve is installed in the tank wall to keep internal tank pressure equal to atmospheric pressure.

#### Valve cleaning

- Remove the oil tank cap.
- Drain the oil tank.

Collect chain oil in a clean container or dispose of it properly at an approved disposal site.

- Remove the inner side plate – 5.4.2

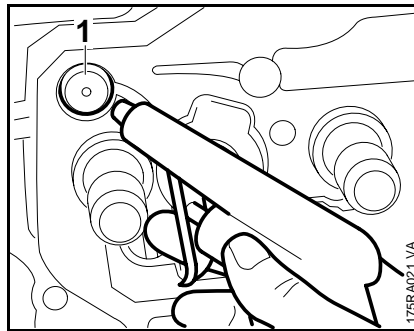

- Blow the valve (1) clear with compressed air (from outside to inside of tank).
- Flush out the oil tank.
- Fit the inner side plate – 5.4.2
- Screw in the oil tank cap.

### 11.2.2 Replacing

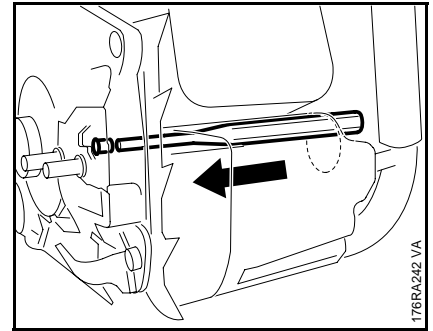

- Remove the oil tank cap.
- Remove the inner side plate – 5.4.2
- Use a 5 mm (0.20 in) drift to carefully drive the valve out of its seat from the inside of the tank.

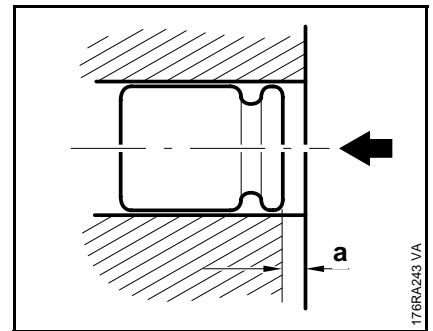

- Use a 7 mm (0.28 in) drift to carefully press home the valve from outside until it is about  $a = 1$  mm (0.04 in) below the housing face.

Reassemble all other parts in the reverse sequence.



## 11.3 Oil pump

### 11.3.1 Removing and installing

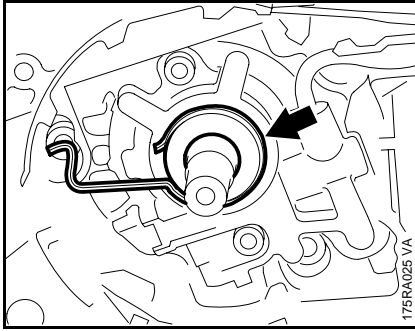

- Remove the clutch – 5.3
- Remove the brake band – 5.4.2
- Pull the worm with drive spring (arrow) out of the oil pump and off the crankshaft stub

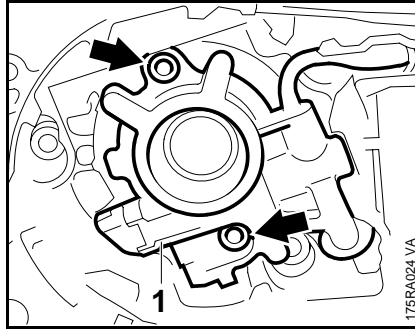

- Take out the screws (arrows).
- Pull the oil pump out of its seat.

Reassemble in the reverse sequence.

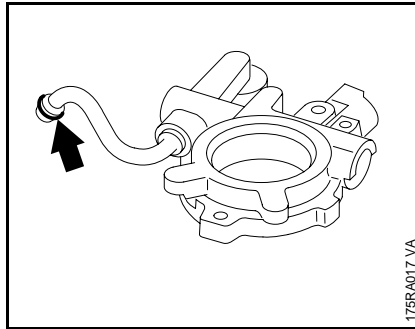

- Place a new O-ring (arrow) in the groove of the oil delivery line.
- Grease the worm at the pump piston – 16.
- Fit the oil pump and tighten down the screws – 3.5

#### Important!

Ensure that the oil delivery line is correctly seated.

- Grease the worm with drive ring before installing it – 16.

Reassemble the other parts in reverse order.

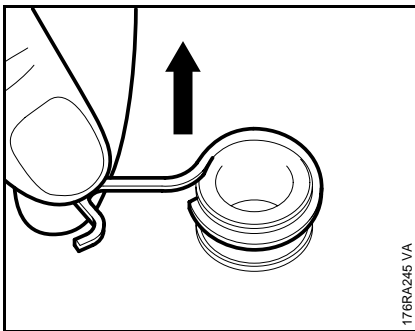

- Remove the drive spring from the worm if necessary.

### 11.3.2 Servicing

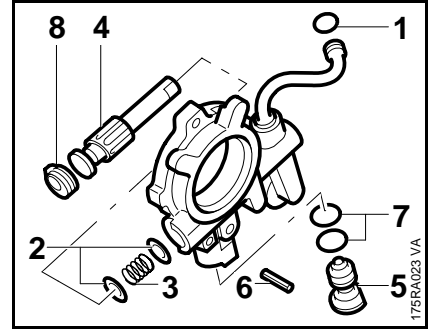

Always check the suction hose and pickup body before disassembling the oil pump.

- Remove the oil pump – 11.3.1
- Remove the O-ring (1).
- Use a 2 mm (0.08 in) drift to drive out the spring pin (6).
- Pull out the control bolt (5).
- Remove the O-rings (7).
- Pry out the plug (8).
- Remove the pump piston (4) with spring (3) and washers (2).

– Clean the individual parts with standard solvent-based degreasant not containing any chlorinated or halogenated hydrocarbons and check that the parts can be reused.

Reassemble in the reverse sequence.

Always install new O-rings.

- Lubricate the pump piston and worm with grease before installing – 16.

**12. Fuel System**  
**12.1 Air Filter**

Dirty air filters reduce engine power, increase fuel consumption and make starting more difficult.

**The air filter should be cleaned when there is a noticeable loss of engine power.**

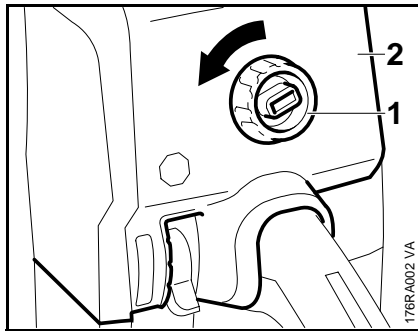

**Machines with box filter**

- Take out the retaining nut (1).
- Remove the carburetor box cover (2).

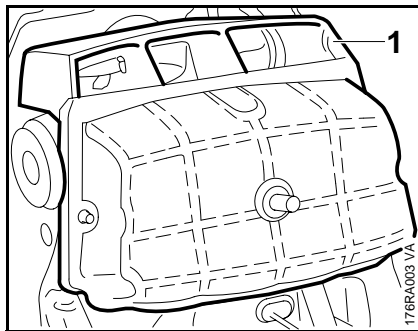

- Pull off the air filter (1).
- Thoroughly wash the air filter and blow through with compressed air; it must be replaced if damaged.

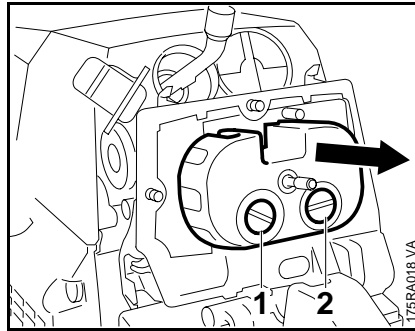

- Unscrew the slotted nuts (1+2).
- Pull off the baffle in the direction indicated.

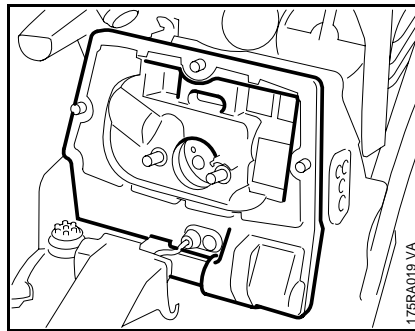

- Remove the filter base.
- Thoroughly wash the filter fabric in the filter base in a clean, non-flammable cleaning solution and blow through with compressed air; it must be replaced if damaged.

The filter base must be replaced if the filter fabric is damaged.

Reassemble in the reverse sequence.

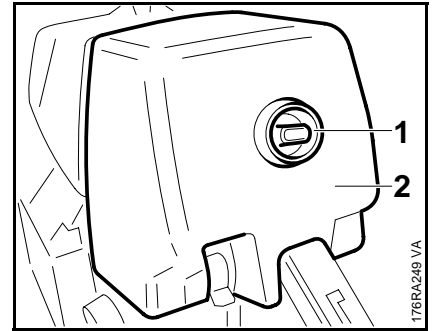

**Machines with HD filter**

- Take out the retaining nut (1).
- Remove the carburetor box cover (2).

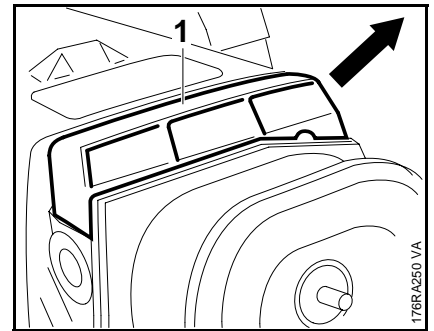

- Pull the air guide (1) up and off.

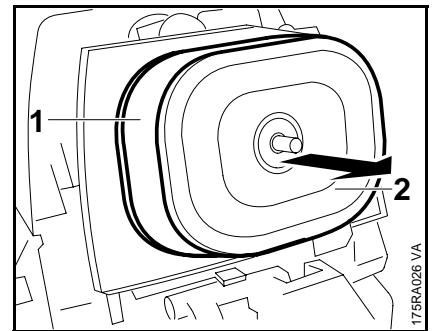

- Remove and replace the pre-filter (1).
- Remove the air filter (2) and replace the internal filter cartridge.

- Thoroughly wash the air filter in a clean, non-flammable cleaning solution and blow through with compressed air; it must be replaced if damaged.

The filter base must be replaced if the filter fabric is damaged.

Reassemble in the reverse sequence.

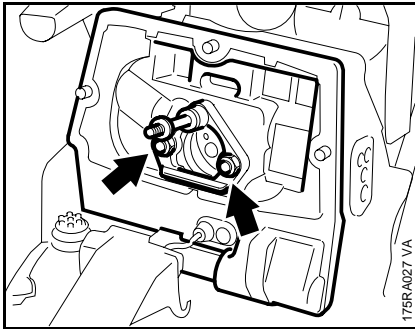

- Unscrew the nuts (arrows).
- Pull off the flange (1).

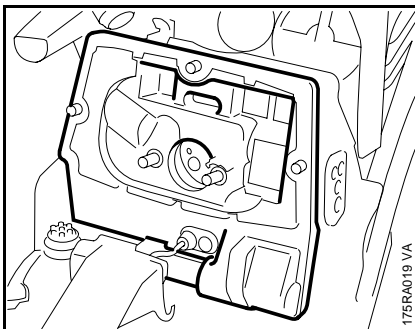

- Remove the filter base.
- Thoroughly wash the filter fabric in the filter base in a clean, non-flammable cleaning solution and blow through with compressed air; it must be replaced if damaged.

## 12.2 Carburetor

### 12.2.1 Removing and Installing

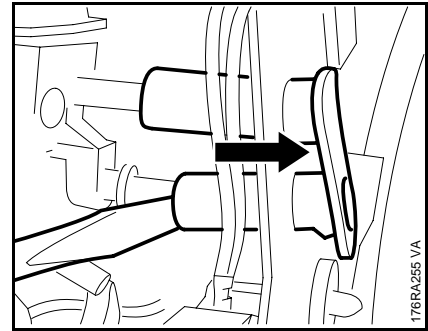

- Remove the filter base – 12.1

- Ease the grommet off the adjusting screws and pull it out of the housing.

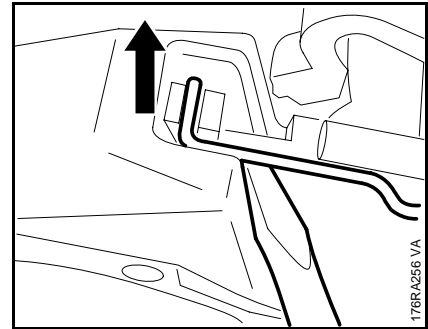

- Open the throttle fully.
- Ease the throttle rod off the trigger.

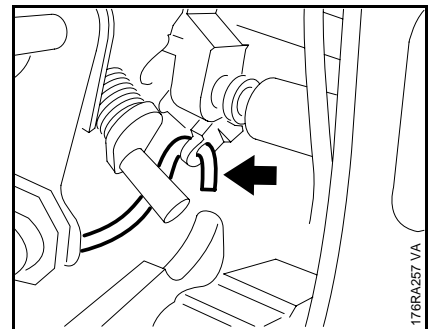

- Unhook the throttle rod from the throttle shaft.

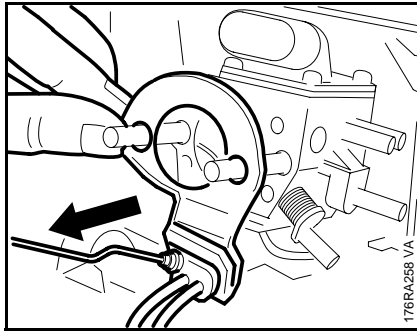

- Pull off the baffle with grommet and throttle rod.

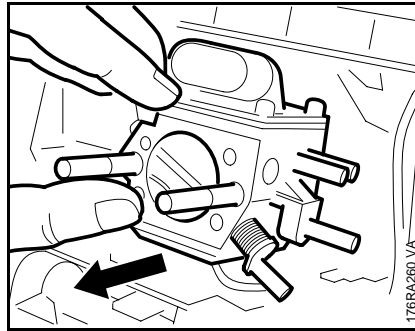

- Take out the carburetor.

Reassemble in the reverse sequence.

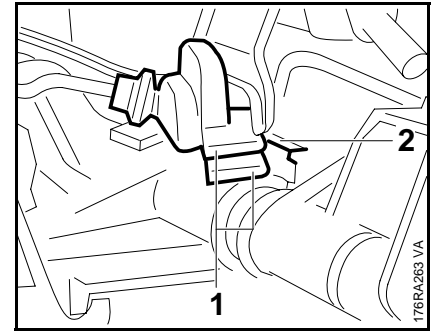

- Insert the grommet so that the rubber lips (1) are located inside the edge (2).

Reassemble the other parts in reverse order.

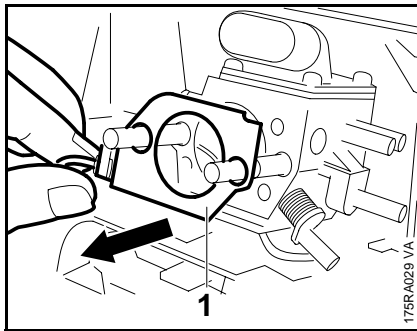

#### Machines with carburetor heating

- Remove the heating element (1) from the stud bolts.
- Unplug the lead to the thermostatic switch –  13.2

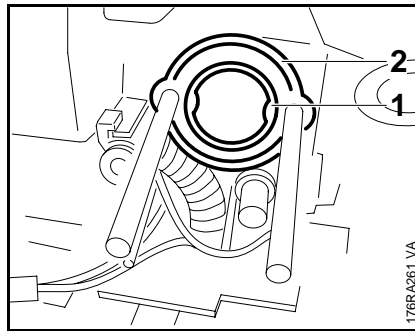

- Ensure that the sleeve (1) and washer (2) are fitted before pushing the carburetor into position.

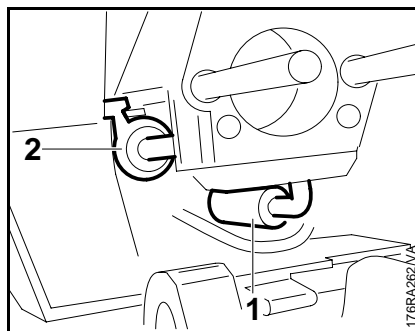

- When pushing the carburetor into position, make sure that the impulse hose (1) and fuel hose (2) are correctly seated.

## 12.2.2 Leakage Test

In the case of problems with the carburetor or fuel supply system, also check and clean or replace the tank vent –  12.5

The carburetor can be tested for leaks with the carburetor and crankcase tester 1106 850 2905.

- Remove the carburetor –  12.2.1

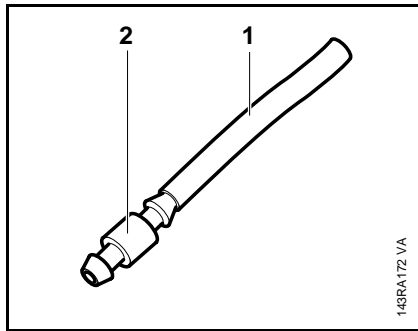

- Push the fuel line (1) 1110 141 8600 onto the nipple (2) 0000 855 9200.

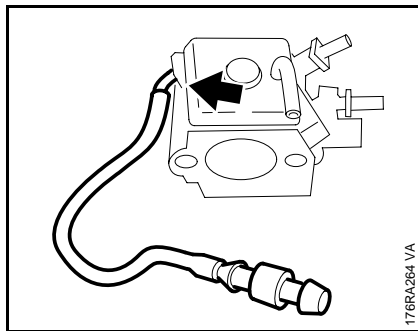

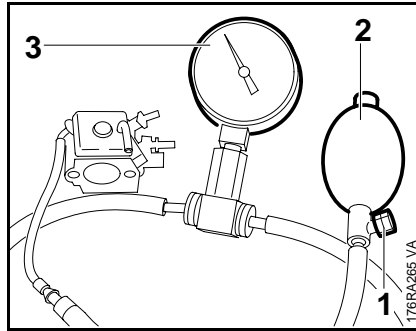

- Push the fuel line with nipple onto the carburetor's elbow connector.



- Push the fuel line with nipple onto the carburetor's elbow connector 1106 850 2905.
- Close the vent screw (1) on the rubber bulb (2) and pump air into the carburetor until the pressure gauge (3) shows a reading of approx. 0.8 bar (11.60 psi).

If this pressure remains constant, the carburetor is airtight. However, if it drops, there are two possible causes:

1. The inlet needle is not sealing (foreign matter in valve seat or sealing cone of inlet needle is damaged or inlet control lever sticking). Remove to clean –  12.3.2
2. Metering diaphragm damaged, replace if necessary –  12.3.1

- After completing the test, open the vent screw (1) and pull the fuel line off the carburetor.

- Push the fuel hose onto the elbow connector.

- Install the carburetor –  12.2.1

Reassemble all other parts in the reverse sequence.

## 12.3 Servicing the Carburetor

### 12.3.1 Metering Diaphragm

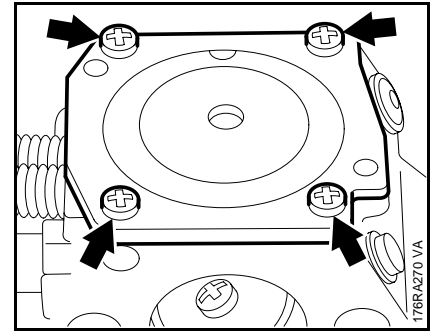

- Remove the carburetor –  12.2.1

- Take out the screws (arrows).

- Remove the end cover.

- Carefully remove the gasket and pump diaphragm from the end cover.

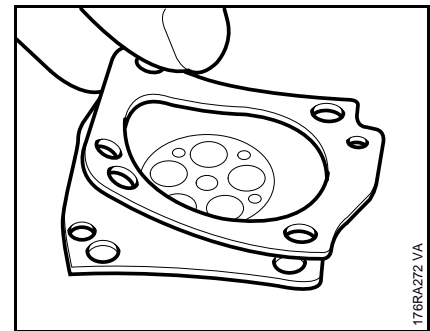

- Carefully separate the diaphragm and gasket.

- Examine the diaphragm for signs of damage or wear, replace if necessary.

### 12.3.2 Inlet Needle

The diaphragm material and the inlet and exhaust valves are subjected to continuous alternating stresses and ultimately show signs of fatigue. The diaphragm distorts and swells and has to be replaced.

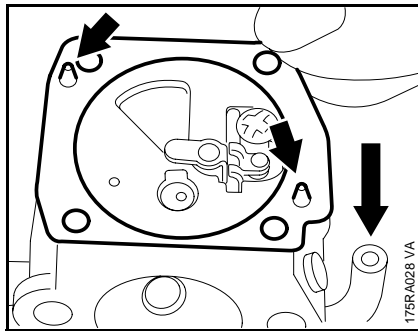

- Place the gasket on the carburetor body.

The gasket and metering diaphragm are located by the integrally moulded pins (arrows).

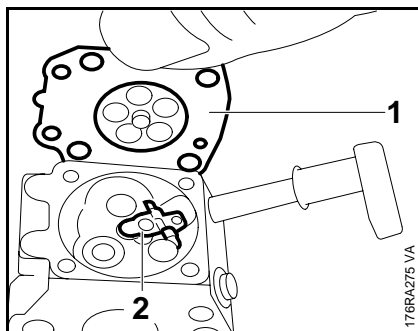

- Fit the metering diaphragm so that the perforated plate (1) faces the inlet control lever (2).
- Fit the end cover.

- Insert the screws and tighten them down firmly.

Reassemble all other parts in the reverse sequence.

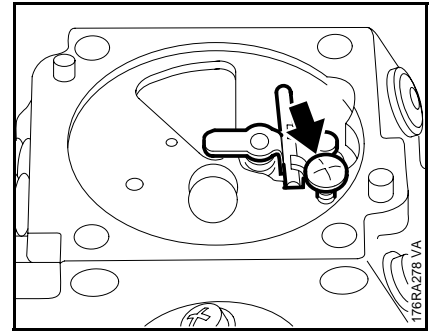

- Remove the metering diaphragm
  -  12.3.1

- Take out the screw (arrow).

- Remove the inlet control lever with spindle.

There is a small spring under the inlet control lever which may pop out during disassembly.

- Take out the inlet needle.

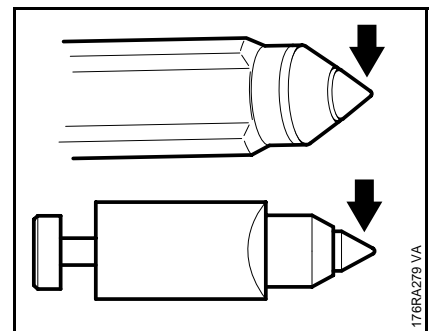

- If there is an annular indentation on the sealing cone of the inlet needle, a new inlet needle must be fitted because a tight seal is no longer assured.

### 12.3.3 Fixed Jet

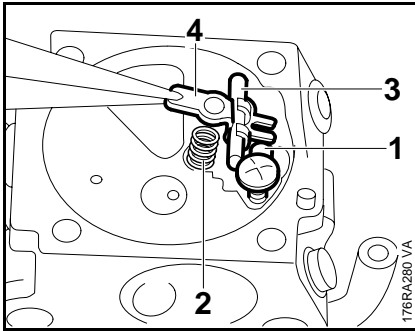

- Fit the inlet needle (1).
- Fit spring (2) in bore.
- Insert spindle (3) in the inlet control lever (4).

– Engage clevis in annular groove on head of the inlet needle.

– Press the inlet control lever down and secure it with the screw.

Make sure the helical spring locates on the control lever's nipple.

– Check that inlet control lever moves freely.

The upper face of the inlet control lever must be flush with the top of the carburetor body.

– Install the metering diaphragm – 12.3.1

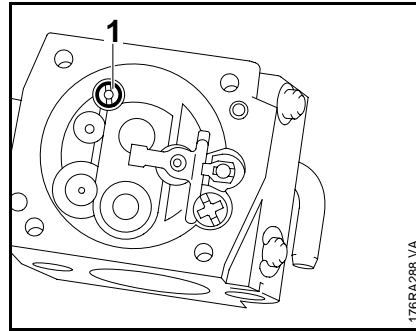

– Remove the metering diaphragm – 12.3.1

● Use a suitable screwdriver to unscrew the fixed jet (1).

The fixed jet must not be damaged by the screwdriver during assembly or disassembly!

Reassemble in the reverse sequence.

### 12.3.4 Pump Diaphragm

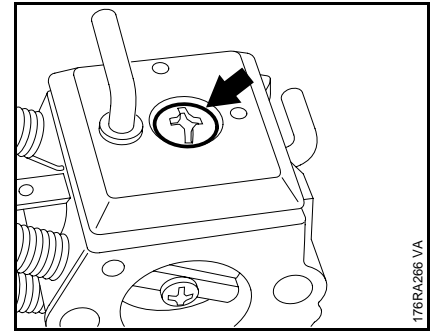

● Take out the screw (arrow).

– Remove the end cover.

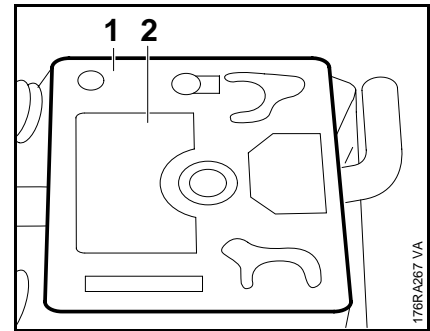

● Remove the gasket (1) and pump diaphragm (2) from the end cover or carburetor body.

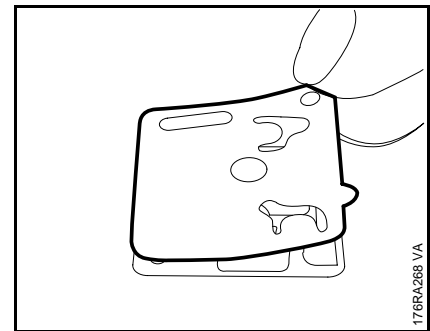

● Carefully separate the diaphragm and gasket.

– Inspect diaphragm for damage and wear, install a new gasket.

## 12.4 Adjustment (carburetor without limiter caps)

The diaphragm material and the inlet and exhaust valves are subjected to continuous alternating stresses and ultimately show signs of fatigue. The diaphragm distorts and swells and has to be replaced.

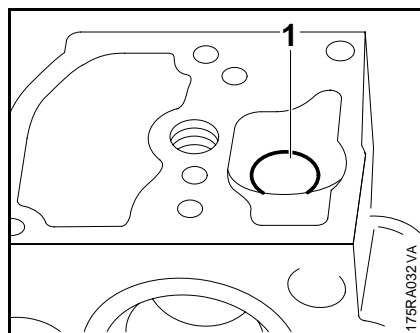

- Inspect the fuel strainer (1) for contamination and damage. If necessary, use a needle to remove it from the carburetor body and clean or replace it.

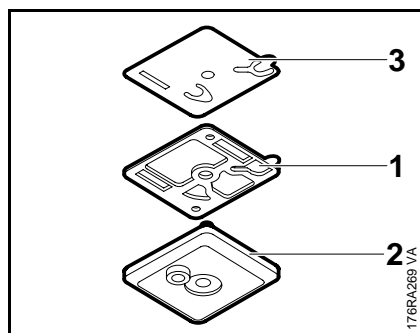

- Place the gasket (1) on the end cover (2).
- Wet the pump diaphragm (3) with fuel and place it on the gasket.

- Place the end cover on the carburetor body.

The pump diaphragm, gasket and end cover are located by the pins integrally moulded onto the end cover.

- Insert the screw and tighten it down.

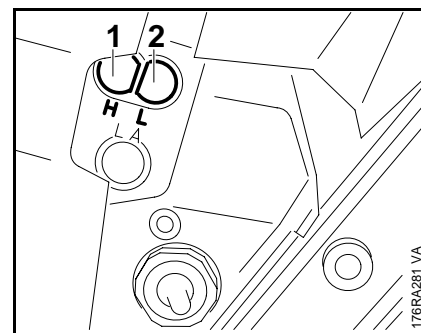

### Standard setting (without tachometer)

The standard setting must be made first when setting a new machine.

- Slowly turn both adjusting screws **H** (1) and **L** (2) clockwise into their seats.

Then adjust as follows:

- Back off high speed screw **H** one turn.
- Back off low speed screw **L** one turn.

If a tachometer is not available, the high speed screw **H** must not be set to a leaner setting than the standard setting.

### Standard setting (with tachometer)

- Check air filter and clean or replace it if necessary.
- Check the spark arresting screen if installed and clean or replace it if necessary.
- Check the chain tension.
- Let the engine warm up.
- Adjust engine idle speed.



## 12.4.1 Adjustment (carburetor with limiter cap)

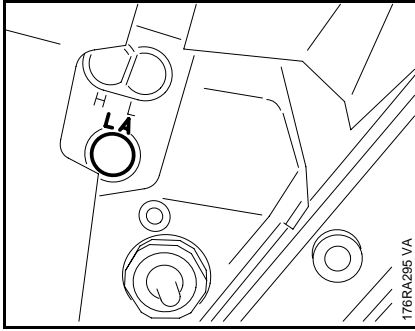

### Adjusting engine idle speed

– Adjust engine idle speed with the tachometer. Set the specified speeds within a tolerance range of +/- 200 rpm.

1. Set the idle speed screw **LA** to a speed of 3,300 rpm.
2. Turn the low speed screw **L** clockwise or counterclockwise until the maximum speed is obtained.

If this speed is greater than 3,700 rpm, stop adjustment and restart with step 1.

3. Set the speed to 3,300 rpm again with the idle speed screw **LA**.
4. Adjust the low speed screw **L** until the speed equals 2,500 rpm.

Starting from the standard setting, set the maximum speed of 13,500 rpm with the high speed screw **H**:

If the setting is made too **lean**, the engine may become damaged as a result of insufficient lubrication and overheating!

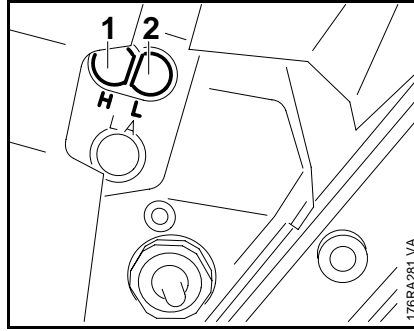

### Standard setting

The limiter cap must not be removed for the standard setting!

- With this carburetor, it is only possible to correct the settings of the high speed screw **H** (1) and low speed screw **L** (2) within fine limits.

Then proceed as follows:

- Open the high speed screw **H** counterclockwise (max. 3/4 turn) as far as stop.
- Close the low speed screw **L** clockwise as far as stop, then open it one quarter turn counterclockwise.

### Adjusting engine idle speed

- Check air filter and clean or replace it if necessary.
- Check the spark arresting screen if installed and clean or replace it if necessary.
- Check the chain tension.
- Let the engine warm up.

Adjust the idle speed with the tachometer. Set the specified speeds within a tolerance range of +/- 200 rpm.

1. Set the idle speed screw **LA** to a speed of 3,300 rpm.
2. Turn the low speed screw **L** clockwise or counterclockwise until the maximum speed is obtained.

If this speed is greater than 3,700 rpm, stop adjustment and restart with step 1.

3. Set the speed to 3,300 rpm again with the idle speed screw **LA**.
4. Adjust the low speed screw **L** until the speed equals 2,500 rpm.

## 12.4.2 Basic Setting (carburetor with limiter cap)

The limiter caps have to be removed from the adjusting screws only if it is necessary to replace the high speed screw (**H**) or low speed screw (**L**), clean the carburetor or carry out the basic setting. Perform the two following operations:

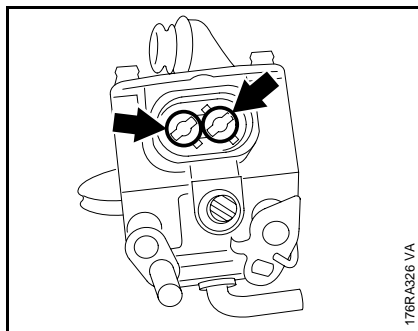

- Turn the limiter cap of high speed screw (**H**) counter-clockwise as far as stop until the limiter cap lugs are in line with the carburetor openings.
- Turn the limiter cap of low speed screw (**L**) clockwise as far as stop. Turn the limiter cap back one quarter turn until its lugs are in line with the carburetor openings.

### Note:

- The lugs of the limiter caps are at a right angle to the screwdriver slot.

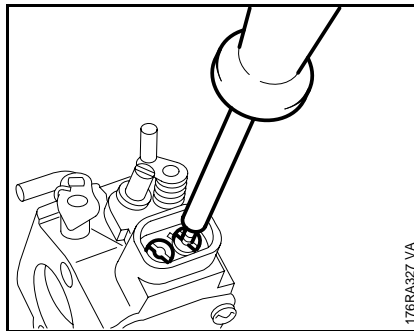

- Insert puller 5910 890 4500 into the middle of the limiter caps and press down lightly, turning counterclockwise at the same time, until the limiter caps can be lifted out of the carburetor body.

The basic setting must be made first after removing the limiter caps!

Proceed as follows:

- Open the high speed screw **H** one full turn.
- Open the low speed screw **L** one full turn.
- Set the idle speed to 2,500 rpm with the low speed screw **L**
- Fit the limiter caps if a tachometer is not available (see step 6).

### Precision adjustment

- Check air filter and clean or replace it if necessary.
- Check the spark arresting screen if installed and clean or replace it if necessary.
- Check chain tension.
- Warm up the engine.

Adjust idle speed with a tachometer. Adjust specified engine speeds within tolerance of +/- 200 rpm.

1. Adjust engine speed with idle speed screw (**LA**) to 3,300 rpm.
2. Turn low speed screw (**L**) clockwise or counterclockwise to obtain maximum engine speed.

If this speed is higher than 3,700 rpm, abort the procedure and start again with step 1.

3. Use the idle speed screw (**LA**) to set engine speed again to 3,300 rpm.
4. Set the engine speed to 2,500 rpm with the low speed screw (**L**).
5. Set the maximum speed to 13,500 rpm with the high speed screw **H**.
6. Install new limiter caps, noting that the stop lugs on the limiter caps must line up with the openings in the carburetor.

Used limiter caps must not be reused as they may be damaged. Always use new limiter caps!

## 12.5 Tank Vent

Correct operation of the carburetor is only possible if atmospheric pressure and internal fuel tank pressure are equal at all times. This is ensured by the tank vent.

### Important!

In the event of trouble with the carburetor or the fuel supply system, always check and clean the tank vent.

Check function by performing vacuum test on the tank via the fuel hose.

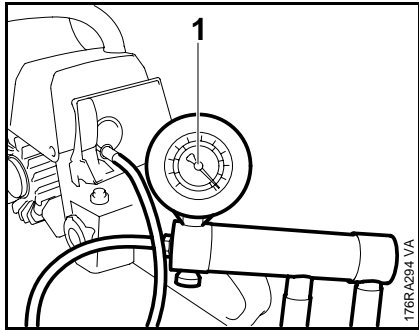

– Remove the carburetor –  
📖 12.2.1

- Connect service tool (1) 0000 850 3501 to the fuel hose and create a vacuum in the fuel tank.

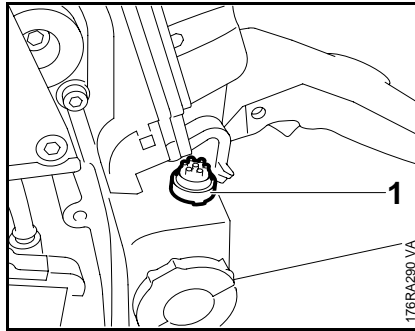

- Equalization of pressure takes place via the tank vent (1). There must not be any build-up of vacuum in the tank. In the event of a malfunction, pry out the tank vent with a slotted screwdriver and fit a new valve with new O-ring.

## 12.6 Pickup Body

The diaphragm pump draws fuel from the tank into the carburetor through the fuel hose. Any impurities mixed with the fuel are retained by the pickup body. The fine pores of the filter eventually become clogged with minute particles of dirt. This restricts the passage of fuel and results in fuel starvation.

In the event of trouble with the fuel supply system, always check the fuel tank and the pickup body first. Clean the fuel tank if necessary.

### Cleaning the fuel tank

- Remove the fuel tank cap and drain the tank.
  - Pour a small amount of clean gasoline into the tank. Close the tank and shake the saw vigorously.
  - Open the tank again and drain it.

Dispose of fuel properly in accordance with environmental requirements!

### Pickup body

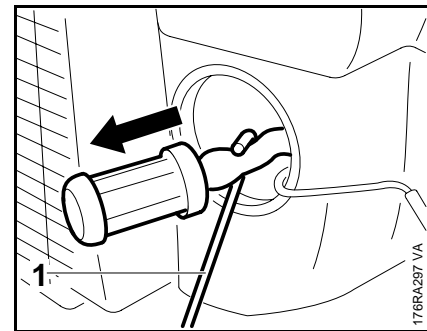

- Use hook (1) 5910 893 8800 to pull the pickup body out of the fuel tank.

Do not stretch the fuel hose too much during this operation.

## 12.7 Fuel Hose

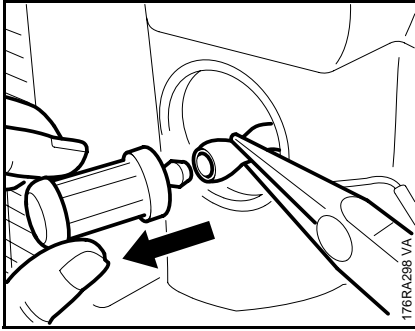



- Pull the pickup body off the fuel hose.

– Fit a new pickup body.

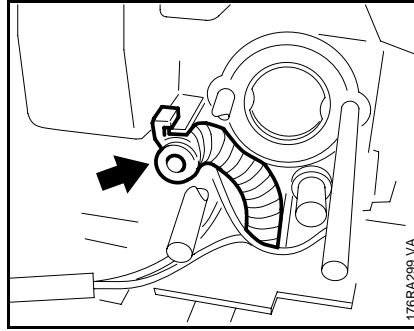
Install in the reverse sequence.



– Remove carburetor –  12.2.1

– Remove pickup body –  12.6

- Pull the fuel hose (arrow) out of its retainer in the tank.

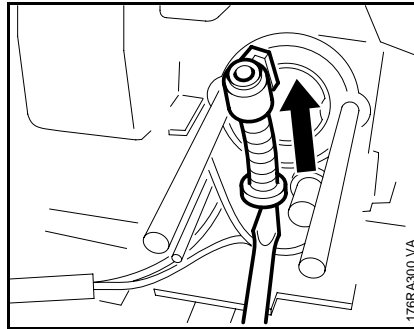

- Pry the flange of the fuel hose out of the fuel tank.

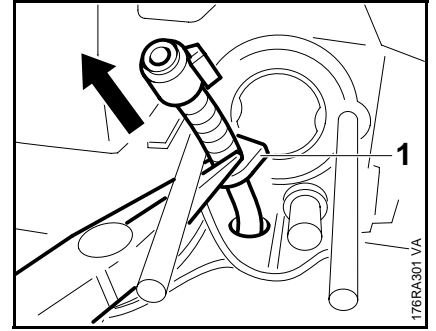

- Pull out the fuel hose.

Install in the reverse sequence.

– Lightly coat the bead of the fuel hose with a little oil.

- The flat edge (1) of the bead must rest against the tank housing.

## 12.8 Tank housing

- Drain the fuel tank.
- Drain the oil tank.

Drain the fuel into a clean container or dispose of properly in accordance with regulations!

- Remove the carburetor – [12.2.1](#)

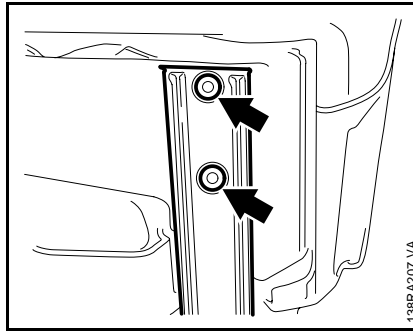

- Take out the lower screws (arrows) on the front handle.
- Remove the front handle.

Disconnect the heating element on machines with handle heating – [14.4](#)

- Unplug the lead from the generator to the handle heating element – [7.5](#)
- On machines with carburetor heating, unplug the lead to the heating element – [7.5](#)

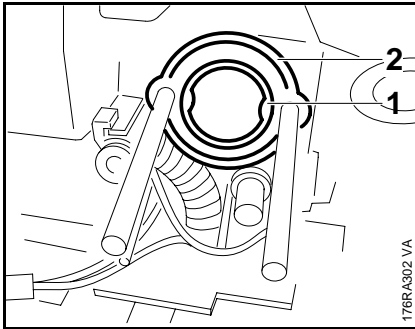

- Pull the sleeve (1) out of the manifold and remove the washer (2) from the stud bolts.

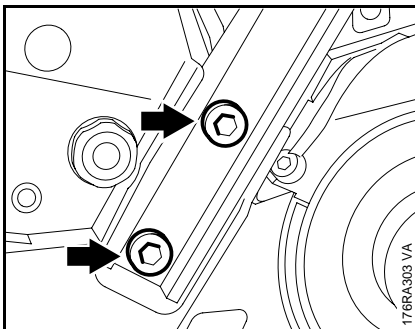

- Take out the screws (arrows) at the side of the front handle.

Heat the screw points, but do not overheat the plastic material.

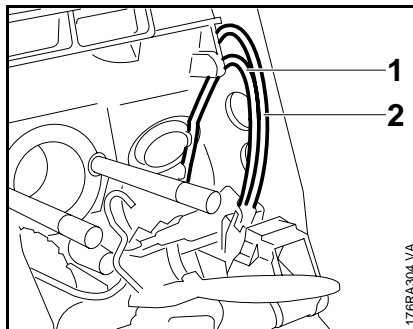

- Unplug the terminal sockets of the short-circuit wire (1) and ground wire (2) from the contact springs.

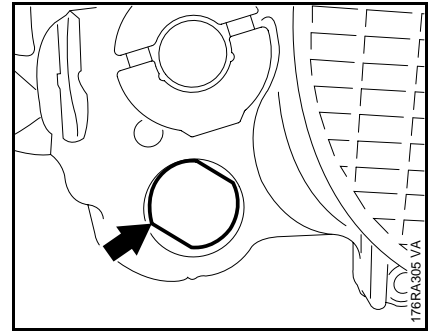

- Remove the heater switch on machines with handle heating – [14.2](#)
- Ease the plug (arrow) out of the annular buffer on the starter side.

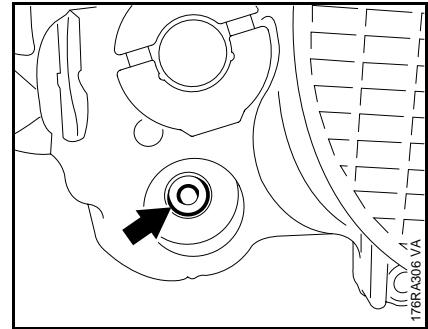

- Take the screw (arrow) out of the annular buffer.
- Remove the inner side plate – [5.4.2](#)

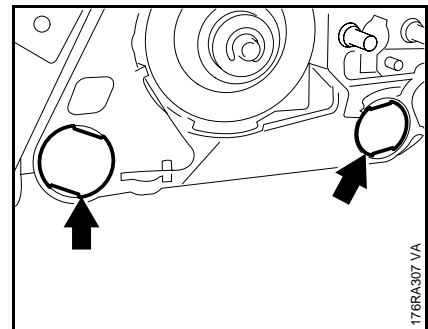

- Remove the chain catcher – [5.2](#)
- Unscrew the plugs (arrows) from the annular buffers on the clutch side.

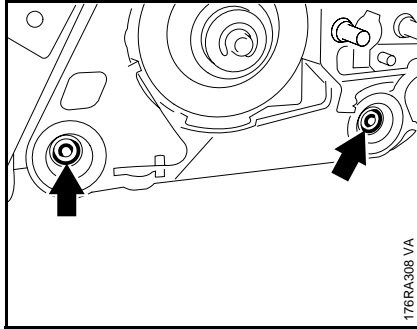

- Take the screws (arrows) out of the annular buffers.

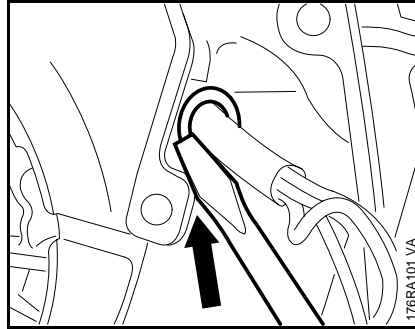

- Turn the tank housing to the side.
- Ease the grommet out of the housing and pull out the wiring harness.

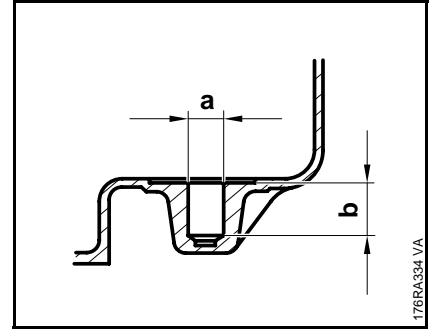

If the screw thread for the special self-threading screws is damaged, the tank housing can be repaired by fitting a threaded insert.

- Drill the damage thread to a diameter  $a = 8.5 \text{ mm}$  (0.33 in) and depth of  $b = 15 \text{ mm}$  (0.59 in).

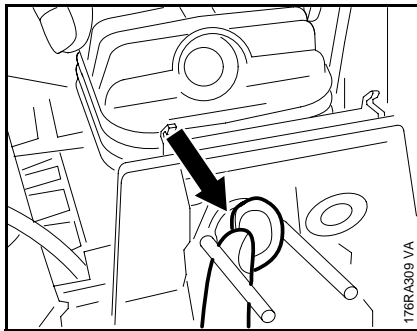

- Pull the tank housing forwards, pressing the manifold flange out of the tank housing at the same time.

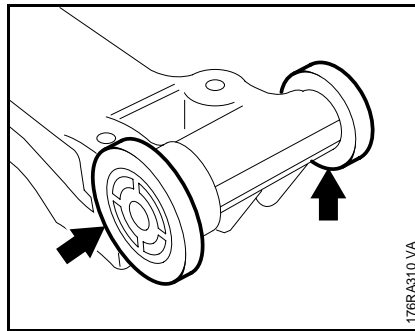

- Remove the rings (arrows) from the tank housing.
- The impulse hose, fuel hose, switch shaft, throttle trigger and tank vent must be removed before replacing.

**Important!**

The required depth of 15 mm (0.59 in) must not be exceeded under any circumstances.

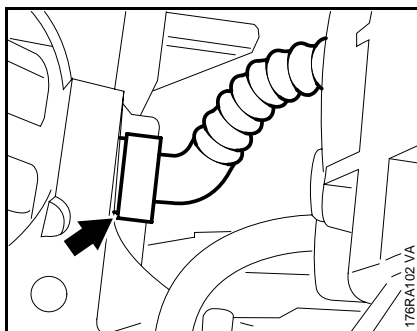

- Unplug the impulse hose (arrow) from the connector.

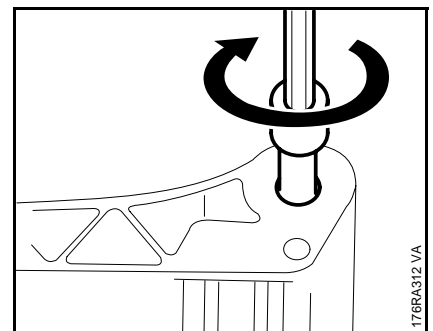

- Turn a size M6x10 screw with washer into the threaded insert.
- Screw the threaded insert into the tank housing.

- Use a size M6x18 screw for attachment instead of the special self-threading screw.

Reassemble in the reverse sequence.

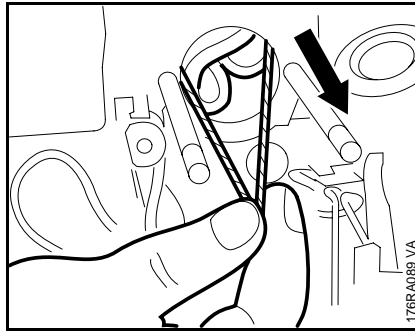

- Pull the ends of string outwards.

In this way, the manifold flange is fitted over the intake opening of the tank housing without damaging the manifold.

- Ensure that the flange is properly seated in the tank housing.

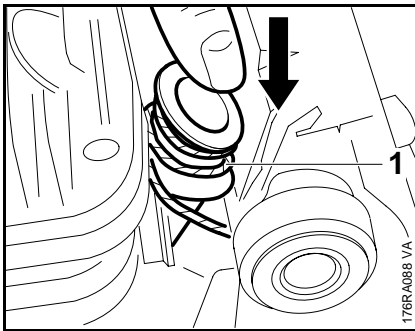

- To pull the manifold flange through the intake opening in the tank housing, wind a piece of string (1) (about 15 cm (5.90 in) long) around the back of the flange, and pass the ends of the string through the intake opening.

- Press the manifold down.

- Push the ends of the string through the opening in the tank housing.

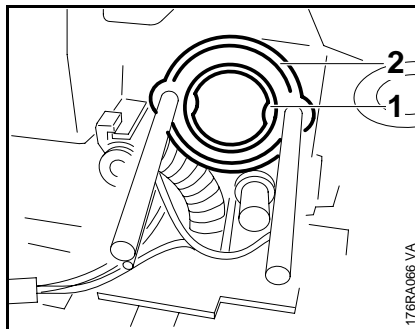

- Mount sleeve (1) in manifold.
- Slide washer (2) onto the stud bolts.

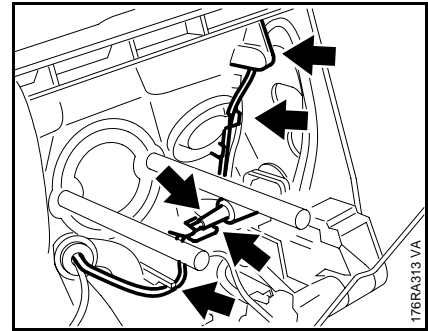

- Check that all wires are correctly routed in the guides (arrows).

- Secure the screws of the front handle with Loctite –  16.

- Tighten down the screws –  3.5

Reassemble all other parts in the reverse sequence.

### 13. Carburetor Heating

Current is supplied via wires to the heating element installed between the baffle and the carburetor.

Carburetor heating is controlled by a thermostatic switch on the heating element

The carburetor heating system should be checked if running problems occur when the cold engine is idling or running at part load, particularly at temperatures below freezing.

Idling problems with a hot engine are also an indication of a fault in the carburetor heating system.

#### Checking correct operation of the complete system

The generator and heating element are tested when checking correct operation of the complete system. An ambient temperature of at least +20 °C (68 °F) is required for this purpose.

If the temperature is lower than + 13 °C (55 °F), the thermostatic switch may close and produce false readings.

Test the thermostatic switch separately.

- Remove the filter base –  12.1

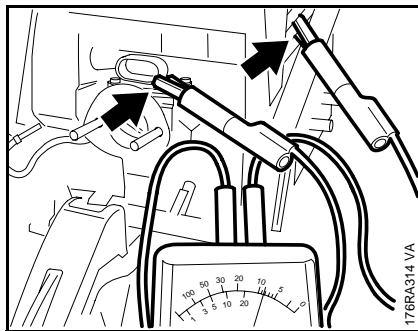

- Set the ohmmeter to measuring range "Ω".
- Clip one of the two test leads to the carburetor body and the other to a cylinder fin (ground).

- If the system is in good condition the ohmmeter will indicate about 8 Ω in measuring range "Ω".

If the reading obtained is outside this tolerance, test each component separately.

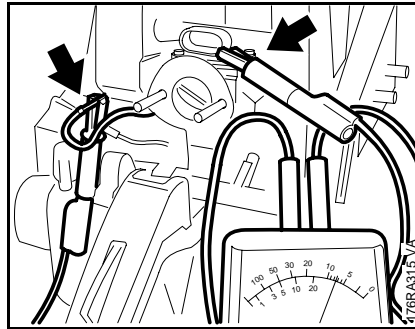

#### Heating element

- Disconnect the lead to the heating element.
- Clip one test lead to the heating plate, the other to the wire that goes to the heating element.
- If the heating element is in good condition the ohmmeter will show a reading of about 8 Ω in measuring range "Ω".

If the reading obtained is outside this tolerance, install a new heating element.

#### Thermostatic switch

- Disconnect the lead to the thermostatic switch.

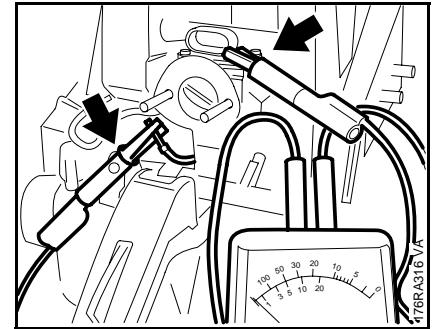

- Clip one test lead to the heating plate, the other to the wire that goes to the thermostatic switch.

At temperatures above + 20 °C (68 °F), the ohmmeter must indicate an infinitely high value in measuring range "Ω".

Cool the switch to below +6 °C (42 °F). The ohmmeter must indicate a value of 0.5 Ω in the "Ω" range. If not, the thermostatic switch is defective and must be replaced.



## 13.1 Troubleshooting Chart

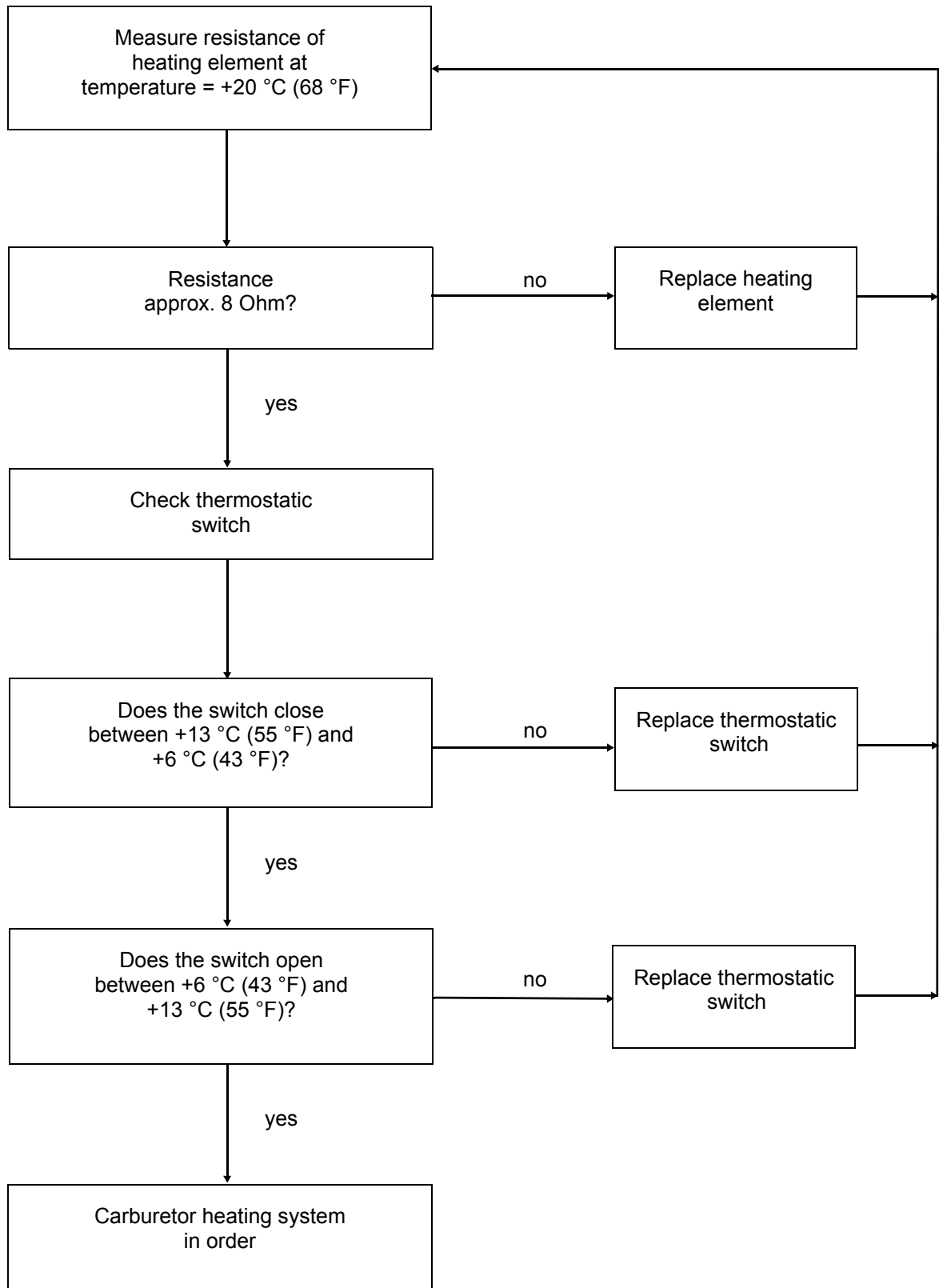

### 13.2 Heating element with thermostatic switch

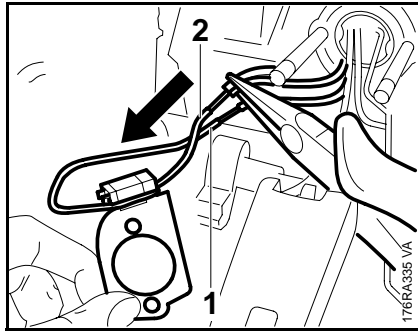

– Remove the heating element –  
 12.2.1

- Unplug the two leads (1+2).

The plug and socket connection must not be bent or kinked during removal or installation, otherwise the parts may break.

Reassemble in the reverse sequence.

Check that the plug connection lies flat after fitting the baffle.

## 14. Handle Heating System

### 14.1 Troubleshooting

The entire handle heating system is maintenance-free and subject to practically no wear. Faults in the generator, heating elements and wiring are generally caused by mechanical damage.

There are two reasons for failures in the heating system:

1. A break in the circuit due to a faulty wire or component.
2. A short circuit resulting from damage to the insulation.

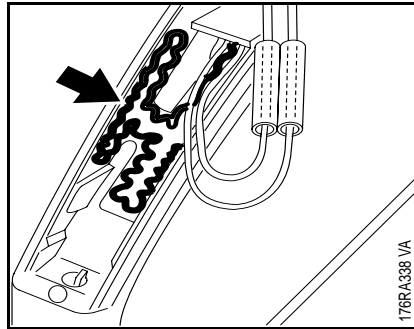

If the affixed heating element in the rear handle does not adhere firmly at all points and without creasing, it may also fail due to overheating.

#### Tracing the cause of a fault

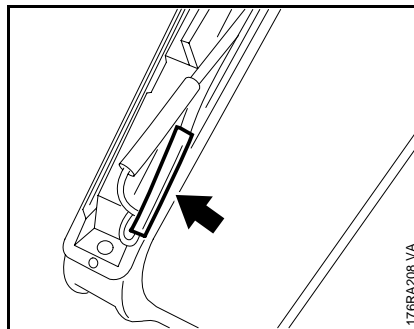

– Remove the interlock lever –  
 10.2

- Remove the protective tubing (arrow) over the plug connecting the lead from the generator to the handle heating element.

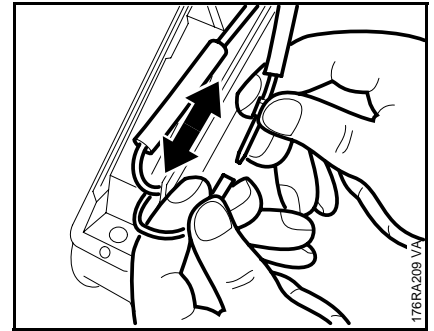

- Unplug the two leads.

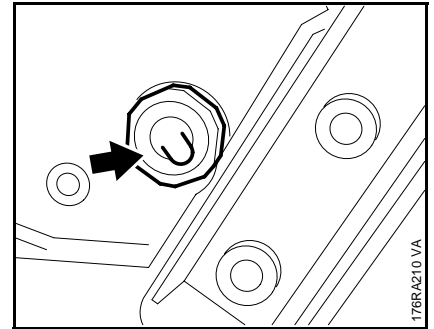

- Set the heater switch (arrow) to position "I".

– Set ohmmeter to "Ω".

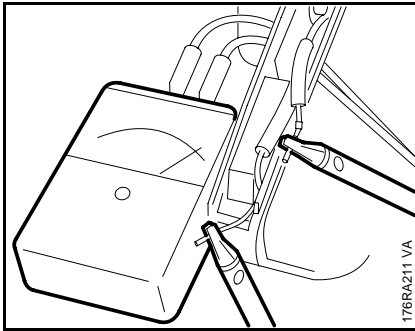

- Clip one of the two test leads to the wire from the generator, the other to the wire leading to the handle heating element.

All electrical components of the heating system are connected in series with the ohmmeter.

If the system is in order, the ohmmeter will show a reading of about  $8 \Omega$  in measuring range " $\Omega$ ".

If the pointer does not move, there is a break in the circuit.

If the ohmmeter shows a very low value, there is a short circuit in one of the components.

In both cases, each component must be tested individually –  14.1

The generator is not connected to the heating element during this time.

- After testing, reconnect the leads and slide the protective tubing back over the plug connection.
- Install the interlock lever and handle moulding –  10.2

### 14.1.1 Troubleshooting Chart

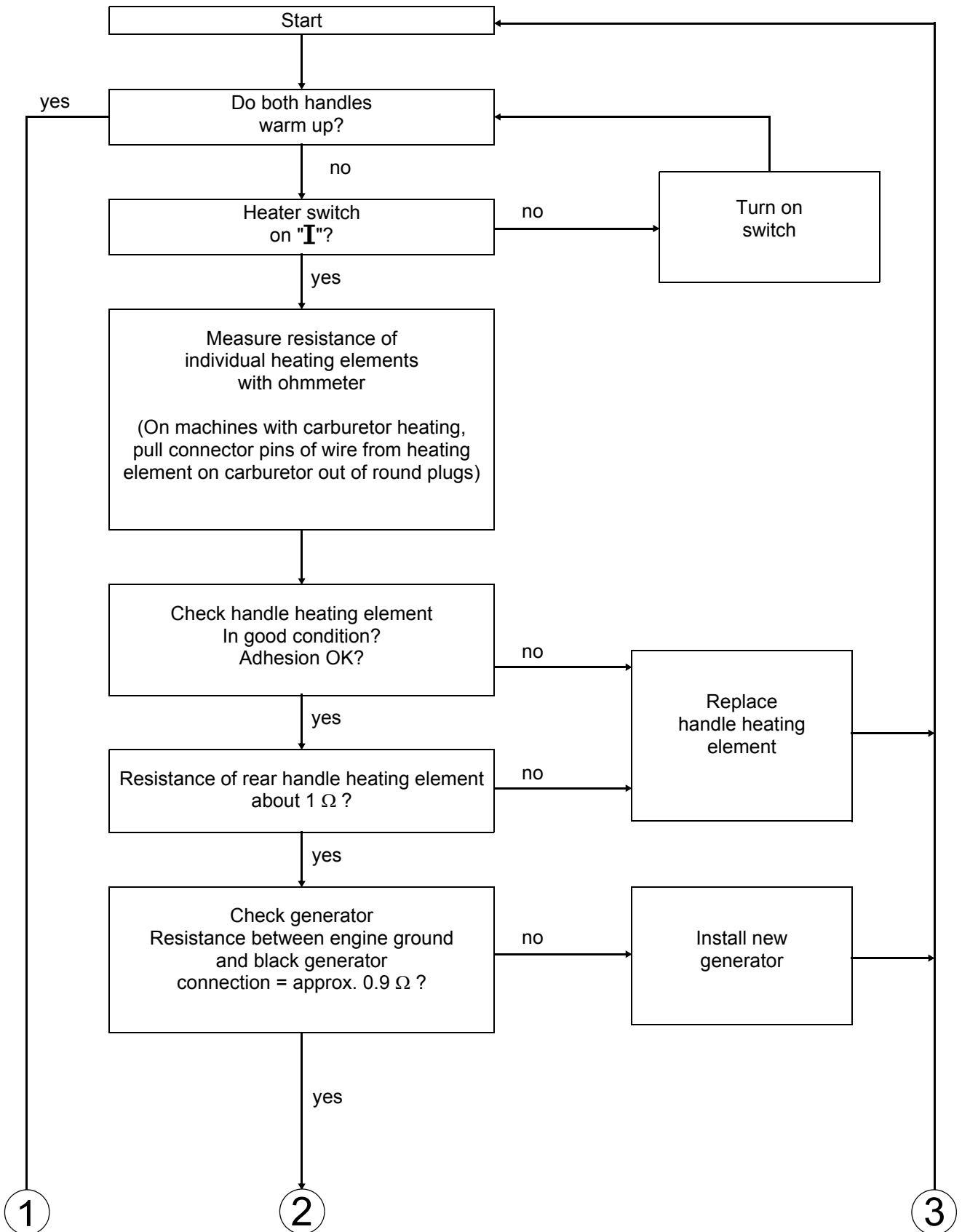

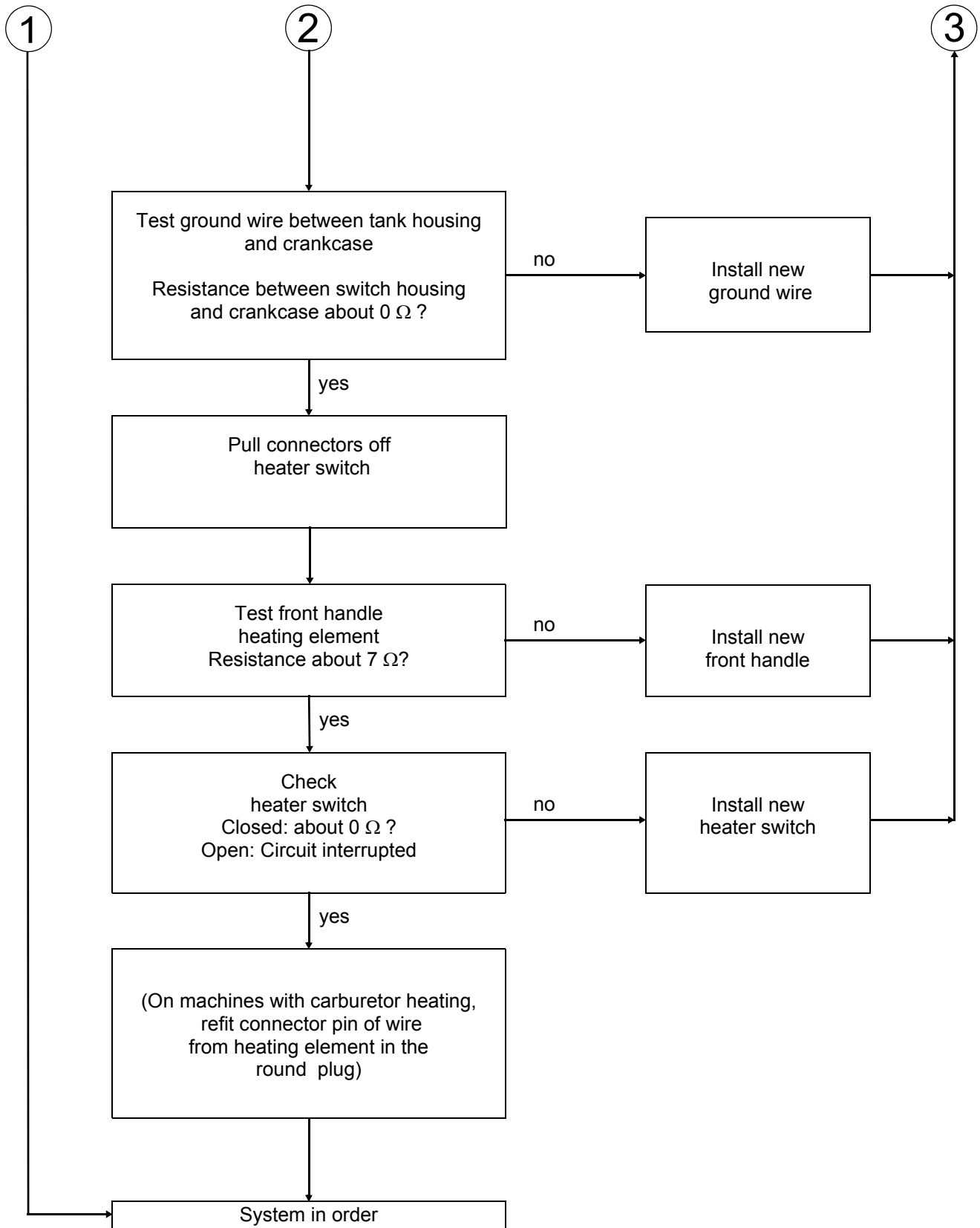

### 14.1.2 Test Connections and Test Values

- The pin and socket connections of the wires in the rear handle must be disconnected to **test the individual components** separately.

Component	Ohmmeter connection (use either test lead)		Resistance $\Omega$		If faulty	
	Lead 1	Lead 2	Spec.	Actual	Cause	Abhilfe
Switch	Switch terminal <sup>1)</sup>	Ground	< 0.5	-	Switch faulty	Schalter ersetzen
Heating element in handle	Plug connector on lead to handle heating element	Plug connector on lead to handle heating element	1.0	0.8...1.2	Heating element OK	Replace heating element or insulate damaged area
				-	Broken wire, heating element damaged	
				0	Short circuit – damaged insulation	
Heating element in front handle	Connector on wire from front handle heating element	Ground	7.0	6.0...8.0	Heating element OK	Install new front handle
				-	Break in wire, heating element damaged	
				0	Short circuit – damaged insulation	
Generator	Connector on wire	Ground	0.9	0.6...1.0	Generator OK	

<sup>1)</sup> Pull out the wire for this purpose

## 14.2 Heater switch

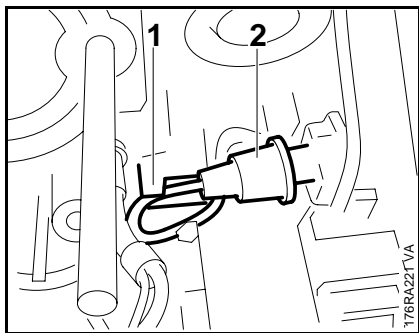

- Remove carburetor – 12.2.1
- Pull the connecting lead out of its mount (1).
- Slide the rubber grommet (2) back slightly.

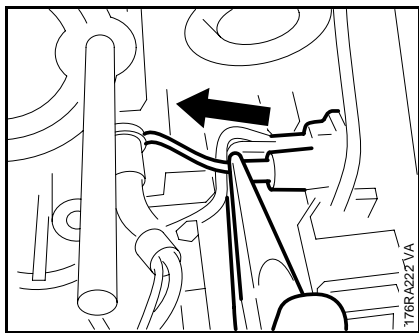

- Pull the contact sleeve of the connecting lead out of the heater switch.

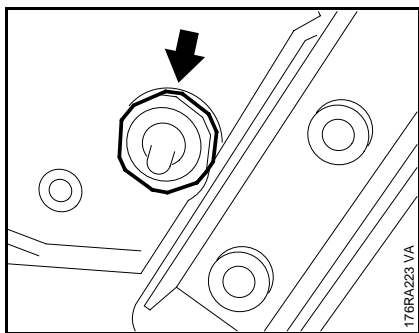

- Unscrew the nut (arrow) on the heater switch.
- Remove the washer.

## 14.3 Heating element in front handle

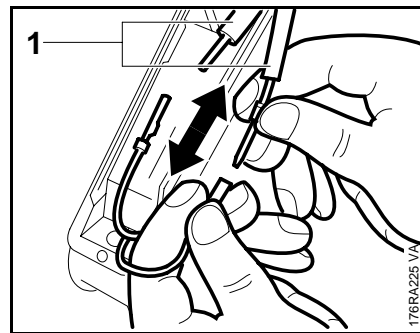

- Remove the interlock lever – 10.2
- Pull the protective tubing (1) off both plug connections.
- Unplug the leads to the handle heating.

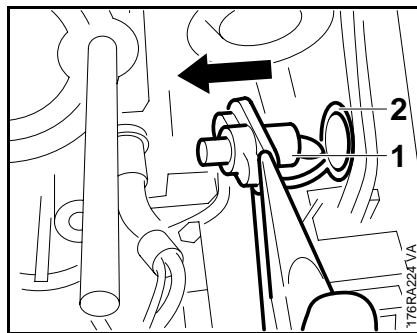

- Pull the heater switch (1) out to the inside.
- Place a new heater switch in the cable lug (2) of the ground wire.
- Insert the heater switch in the hole.
- Slip the washer into place.
- Screw on the nut and tighten it down.
- Push the contact sleeve of the connecting lead into the switch.
- Slip the rubber grommet over the connection.
- Press the connecting lead into the mount.
- Install the carburetor – 12.2.1

## 14.4 Heating element in front handle

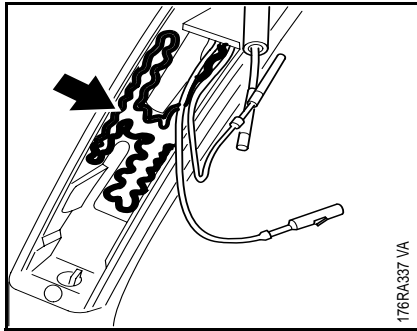

- Remove the pressure element and heating element from the handle moulding.

Before fitting a new heating element, clean the bonding area in the handle to remove all grease, dirt and moisture.

- Peel the backing off the new heating element.

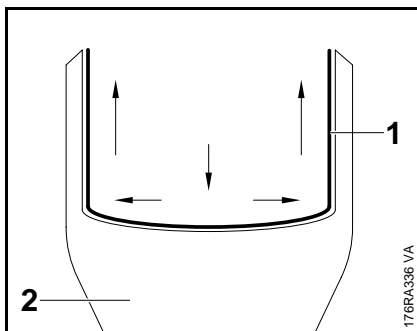

- Place the heating element (1) in the handle moulding (2) and press it into place uniformly from the inside outwards.

The heating element must lie flat without creasing. If it does not adhere firmly and uniformly at all points, heat transmission will be interrupted and the heating element will fail due to overheating. The ambient temperature must be at least +15 °C (59 °F) during installation.

Reassemble in the reverse sequence.

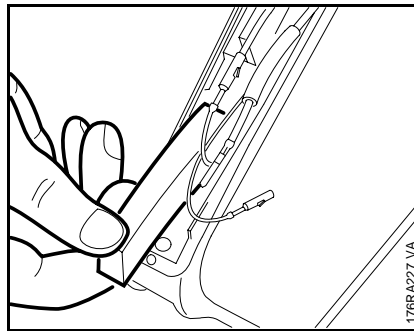

- Place a new pressure element (cellular rubber moulding) on the heating element, ensuring that the entire heating element is covered.
- Plug both leads together again.
- Slide the protective tubing over the plug connections.
- Install the interlock lever – 10.2

### Check operation of the heating element

Run the machine at full throttle for not more than 30 seconds with the heater switched on

The heating element in the front handle cannot simply be replaced if defective. The complete handle must be replaced in this case.

- Remove the carburetor – 12.2.1
- Remove the interlock lever – 10.2
- Take off the protective tubing over the plug connection in the lead from the front handle heating element to the rear handle heating element.

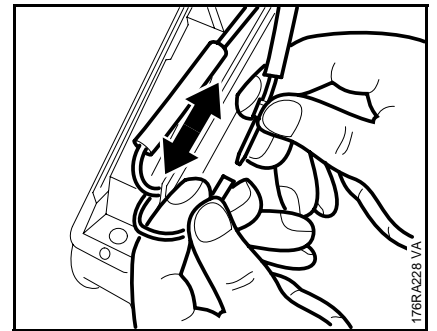

- Unplug the two leads.

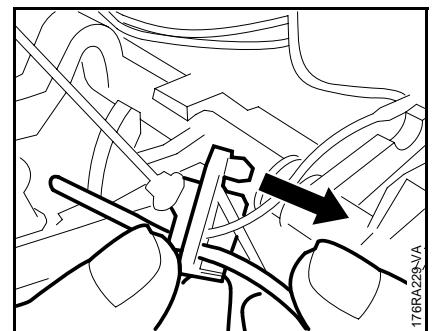

- Pull the leads out of the rubber grommet.
- Pull the connecting wire out of the heater switch – 14.2



## 14.5 Generator

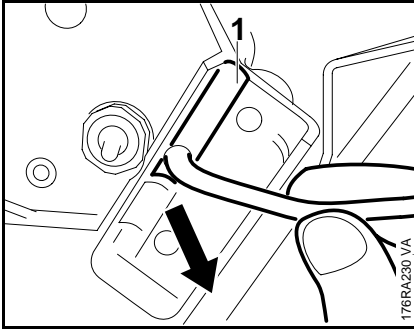

– Remove the front handle –  
 12.8

- Pull the connecting lead out of the opening.

Reassemble in the reverse sequence.

- Lay the connecting leads in the recess (1) when fitting the front handle.

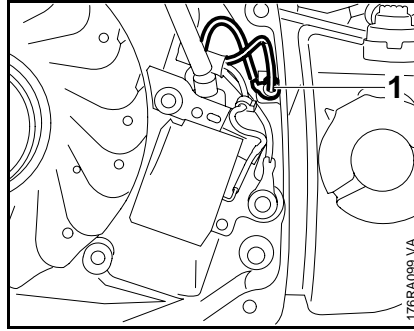

– Remove the ignition module –  
 7.1.2

– Remove the flywheel – 7.3

- Break the connection (1).

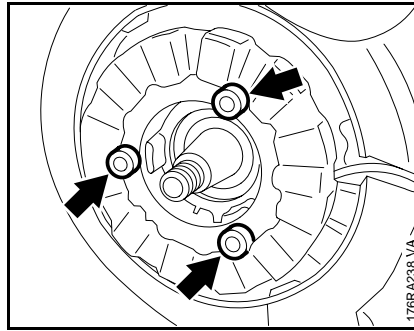

- Take out the screws (arrows).

– Remove the generator.

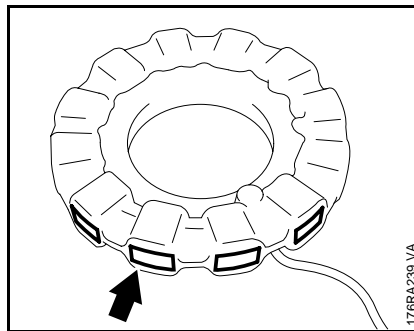

- There must not be any cracks or other signs of damage on the generator and poles, otherwise they must be replaced.

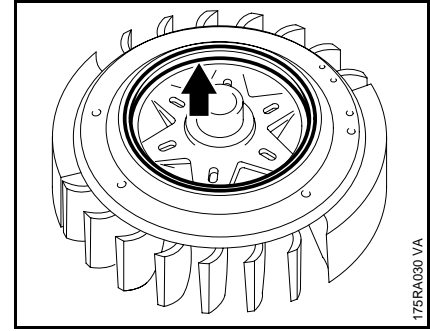

- There must not be any cracks or other signs of damage on the magnet ring (arrow) in the flywheel, otherwise it must be replaced.

Reassemble in the reverse sequence.

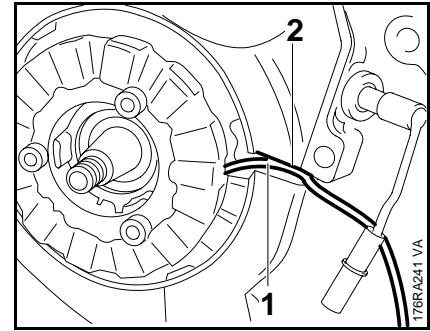

- Position the generator with the connecting lead (1) facing the housing.

- The connecting lead must be located beside the recess (2) in the housing.

– Secure the screws with Loctite 242 – 16.

– Tighten down the screws – 3.5

Reassemble the remaining parts in reverse order.

## 15. Special Servicing Tools

No.	Part Name	Part No.	Application	Rem.
1	Locking strip	0000 893 5903	Blocking the crankshaft	
2	Sealing plate	0000 855 8106	Sealing exhaust port	
3	Wooden assembly block	1108 893 4800	Fitting piston	
4	Clamping strap	0000 893 2600	Compressing piston rings	
5	Test flange	1128 850 4200	Leakage test	
6	- Bushing	0000 963 1008	Supplement to test flange 1106 850 4201	
7	Carburetor and crankcase tester	1106 850 2905	Testing carburetor and crankcase for leaks	
8	Vacuum pump	0000 850 3501	Testing crankcase for leaks, checking tank vent	
9	- Nipple	0000 855 9200	Testing carburetor for leaks	
10	- Fuel line	1110 141 8600	Testing carburetor for leaks	
11	- Plug	1122 025 2200		
12	Puller	5910 890 4400	Removing oil seals	
13	Jaws (No. 3.1 + 4)	0000 893 3706	Removing oil seal(s)	
14	Jaws (No. 6)	0000 893 3711	Removing oil seal(s)	
15	Installing tool	1128 890 3900	Installing oil seal (starter side)	
16	Installing sleeve	1122 893 4600	Protecting oil seal (clutch side)	
17	Press sleeve	1118 893 2401	Installing oil seal (clutch side)	
18	Assembly drift	1111 893 4700	Removing and installing the piston pin	
19	Installing tool 12	5910 890 2212	Fitting hookless snap rings in piston	
20	Stud puller M8	5910 893 0501	Removing bar mounting studs	
21	Installing tool	1116 893 4800	Rewinding the rewind spring	
22	Setting gauge	1111 890 6400	Setting air gap between ignition module and flywheel	
23	Hook	5910 893 8800	Removing pickup body	
24	Assembly stand	5910 890 3100	Holding saw for servicing / repairs	
25	Service tool AS	5910 890 2005	Removing and installing crankshaft	
26	Assembly tube	1117 890 0900	Detaching and attaching clutch springs	
27	Service tool AS (set)	5910 007 2205	Removing crankshaft (clutch side)	
28	Screw sleeve	5910 893 2420	Installing crankshaft	
29	Service tool ZS (set)	5910 007 2220	Removing crankshaft (starter side)	
30	Screw sleeve	5910 893 2409	Pulling crankcase halves together	
31	Puller	5910 890 4500	Removing limiter caps	

No.	Part Name	Part No.	Application	Rem.
32	Puller for flywheel	1110 893 4500		
33	Torque wrench	5910 890 0301	0.5 to 18 Nm (0.37 to 13.28 in) Alternative: Torque wrench 5910 890 0302 with optical/acoustic signal	
34	Torque wrench	5910 890 0311	6 to 80 Nm (4.43 to 59.00 in) Alternative: Torque wrench 5910 890 0312 with optical/acoustic signal	
35	Crimping tool	5910 890 8210	Attaching connectors to electrical wires	
36	Socket, 13 mm, DIN 3124	5910 893 5608	Flywheel nut	
37	Socket, DIN 3124-S19x12.5L	5910 893 5613	Clutch	
38	Screwdriver bit T 27 x 125	0812 542 2104	Removing and installing spline socket head screws with electric or pneumatic screwdrivers; tighten down screws with torque wrench	
39	T-handle screwdriver, T 27 x 150	5910 890 2400	IS-P screws (4 mm)	1)
40	Press arbor	1118 893 7200	Removing and installing ball bearing (clutch side)	
41	Press arbor	1120 893 7200	Removing and installing ball bearing (flywheel side)	
42	Pliers, DIN 5254-A 19	0811 611 8380	Removing and installing external retaining rings	

Remarks:

1) Use only for releasing P screws.

## 16. Servicing Aids

No.	Part Name	Part No.	Application
1	Lubricating greas (225g (0.50 lb) tube)	0781 120 1111	Oil seals, oil pump drive, chain sprocket bearing, sliding and bearing points of brake band, pawl pegs
2	Ignition lead HTR (10 m (32.81 ft)	0000 930 2251	
3	STIHL special lubricant	0781 417 1315	Bearing bore in rope rotor, rewind spring in fan housing
4	Dirko grey sealant (100 g (0.22 lb) tube)	0783 830 2120	Engine pan, oil seals (outside)
5	Standard commercial solvent- based degreasant containing no chlorinated or halogenated hydrocarbons		Cleaning sealing faces
6	STIHL multipurpose grease	0781 120 1109	High voltage output on ignition module
7	Medium-strength threadlocking adhesive (Loctite 242) (250 ml (8.25 fl.oz) bottle)	0786 110 0116	
8	High-strength threadlocking adhesive (Loctite 270) (50 ml (1.65 fl.oz) bottle)	0786 111 1109	
9	High-strength threadlocking adhesive (Loctite 649) (50 ml (1.65 fl.oz) bottle)	0786 110 0126	
10	Press Fluid OH 723	0781 957 9000	



**englisch / english**

0455 175 0123. M0. E6. Printed in Germany