

024

Technical Information



T.5.83

Engineering Changes on Stihl's Model 024 Chain Saws (Series 1121):

- 1) Centrifugal clutch
- 2) Wire snap ring (piston pin retainer)
- 3) Rim sprocket (special accessory)
- 4) Trigger unit for ignition system (correction of part number)

1. Centrifugal clutch:

In order to improve operation, the present Clutch Springs, 0000 997 5625, will be replaced by stiffer ones, 0000 997 5626, starting with machine number X 10 955 600. As the size difference of the springs is only nominal, the new Spring, 0000 997 5626 will be colored white for the sake of easy identification.

The original type springs can be used for the clutches of the Stihl 020 saws. The new spring (white) is not, however, suitable for use in 020 clutches as the clutch would drop out of engagement at too high an engine speed and this would result in overheating and premature clutch wear.

Clutch 1121 160 2000, will only be supplied with these new springs in the future. The springs on existing stocks of clutches should be changed before the clutches are installed.

Summary:

	Original version	New version
Centrifugal clutch, consisting of:	1121 160 2000	1121 160 2000
Carrier	1121 160 2300	1121 160 2300
Clutch shoe	1121 162 0800	1121 162 0800
Clutch spring (yellow)	0000 997 5625	---
Clutch spring (white)	---	0000 997 5626

2. Wire snap ring (piston pin retainer):

From machine No. X 10 986 435 there will be an installation groove in the piston boss so that the C 10 hookless snap rings can be used for retaining the piston pin. Although it takes a little more time to fit and remove these new snap rings, they are more reliable than "hooked snap rings", especially at high R.P.M.



At the present time Cylinders, 1121 020 1200 and Piston, 1121 030 2000, are still being supplied as spare parts with a single hook snap ring.

The B 10 snap rings, with 1 hook, 9462 650 1010, will continue to be supplied for service pistons, without the installation groove.

Service note:

Only B 10 snap rings, with 1 hook, may be used on pistons which have no installation groove since hookless snap rings can only be removed with great difficulty from such pistons.

On pistons with the ring installation groove, the hookless snap rings are removed by inserting a scriber or similar tool in the groove and "picking out" the snap ring (see illus. at right).

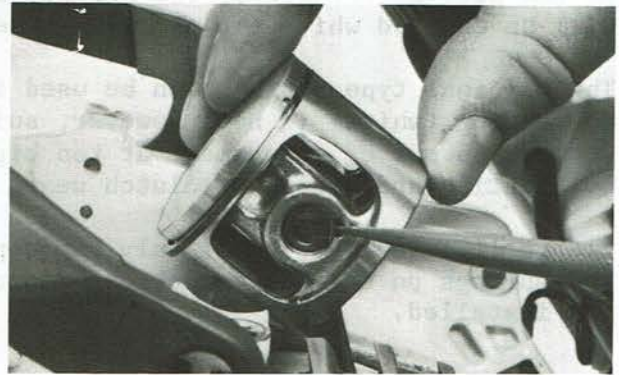

It is only necessary to remove one snap ring in order to push out the piston pin with the assembly tool, 1110 893 4700. The new installing Pliers, 5910 890 8200, simplify fitting of the snap ring. The pliers are used as follows:

* Position snap ring in slot of open pliers so that the ring gap is not near the slot. The slide must be pulled back fully.

* Close the pliers, squeeze firmly together and move the slide in a few millimeters at the same time. The pressure on the pliers can then be released.



* Apply the sleeve of pliers to piston boss and push slide fully home. The snap ring slips into the piston boss in the process (see illus. to right).

Replacement pistons are already equipped with a snap ring in the piston boss at the clutch side. This means that the piston pin must always be fitted from the ignition side.

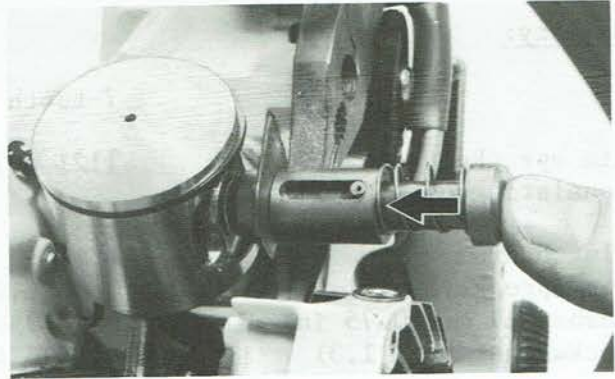

Summary:

	Original version	New version
Cylinder with piston; including:	1121 020 1200	1121 020 1200
Piston assy., including:	1121 030 2000	1121 030 2000
Wire snap ring (B 10)	9462 650 1010	---
Wire snap ring (C 10)	---	9463 650 1000
all other parts unchanged		

3. Rim sprocket (special accessory):

Rim sprockets (0.325") with 7 and 8 teeth are now available for Stihl's model 024 saws. Since the 024 was originally designed to take rim sprockets, installation only requires that the standard sprocket be exchanged for the new clutch drum and rim sprocket.

Note on assembly:

The rim sprocket must be positioned on the hub of the clutch drum so that the side with the wood chip openings faces outward. Moreover, washer 0000 958 1009 (19 mm / 0.75 in dia.) must be fitted in place of washer 0000 958 0506 (29 mm / about 1.14 in dia.). This is to ensure that the chips can drop out of the "pockets" in the sprocket.

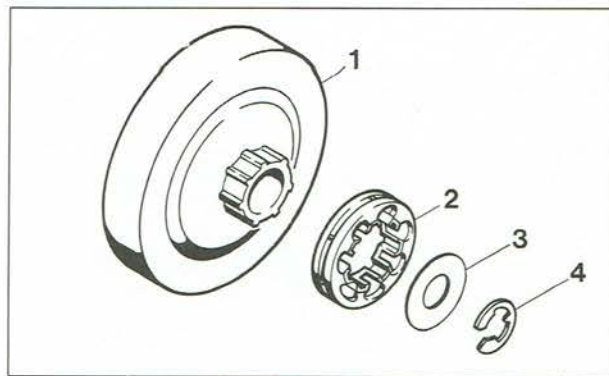

Summary:

	7-tooth	8-tooth	Ind.-No.
Rim sprocket kit, 0.325"; consisting of:	1121 007 1001	1121 007 1002	
Clutch drum	*	*	1
Rim sprocket	0000 642 1236	0000 642 1234	2
Washer 19 mm (0.75 in) dia.	0000 958 1009	0000 958 1009	3
Lockwasher (8 x 1.3)	9460 624 0801	9460 958 0801	4

*Not available as separate item

4. Trigger unit for ignition system (correction of part number):

Please note that the correct part number for the 024 electronic unit is, 1118 400 1004. Thank you.

U/TSM:tc

243/312

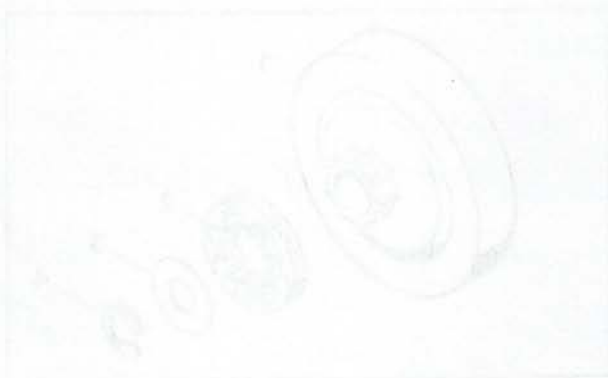

Model 026 "PRO" Chainsaw - Series 1121

Contents

1. STIHL 026 "PRO" Air filter system with compensator (air filter, carburetor, carburetor box cover), Decompression valve (cylinder, shroud)
2. 026 oil pump (service note)
3. Chain brake (stronger brake spring)

1. Air filter system with compensator decompression valve

A new model 026 "PRO" chainsaw will come with a newly developed air filter system and decompression valve. The filter system considerably improves particle retention and, together with the compensator, helps extend filter service life many times over. This permits very long periods of operation and thus reduces maintenance costs. The decompression valve helps bring about a considerable increase in starting comfort. The assemblies and parts affected by the modification are described below.

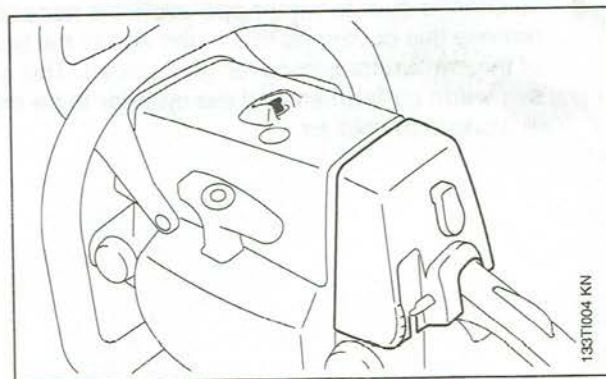

1.1 Air filter system with compensator

Benefits and features of the new **air filter**:

- Much larger filter area
- Filter fabric made of two-ply polyamide (instead of wire mesh)
- Integrally molded baffle (no longer available as separate item)
- Redesigned and optimized choke shutter
- Inner half of filter with connector for compensator
- Retaining lugs for the carburetor box cover
- A "felt" filter is available in place of the "flocked" air filter

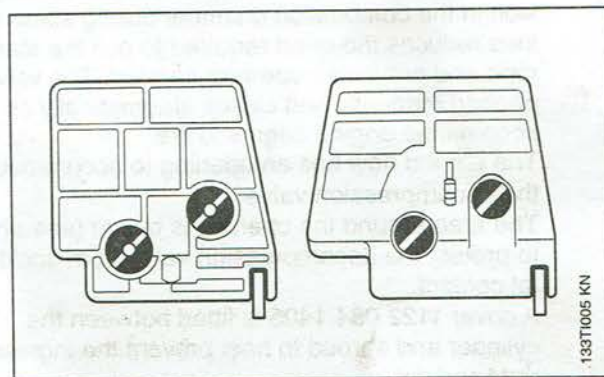

Standard 026 version

New 026 "PRO" version

The connector on the metering end cover of the new **carburetor** projects into the inner half of the air filter. This connection between the clean air side of the air filters and the outside of the metering diaphragm produces the compensator effect. The **compensator** keeps the fuel content in the air flow constant at all times, irrespective of how dirty the air filter is. The mixture cannot become over-rich and it is no longer necessary to change the setting of the high speed screw as contamination of the air filter increases.

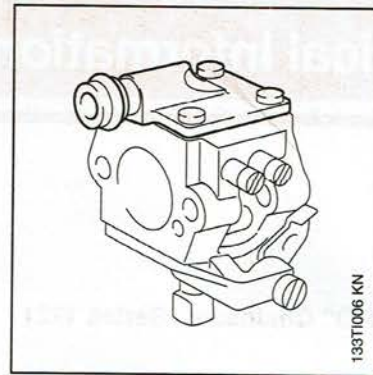

The new **carburetor box cover** has been designed so that combustion air is no longer drawn in at the top (through the gap), but at the bottom (between the carburetor box cover and tank housing). The carburetor box cover is secured to the air filter with a twist-lock lever (1) which turns through 90°. The original wire mesh prefilter has been replaced by an integrally molded plastic screen which is sealed off for summer operation by cover (2). To change over to winter operation it is necessary to remove this cover and fit it in the slot at the bottom of the carburetor box cover (see arrow). This causes warm air from around the cylinder to be drawn in along with cold air.

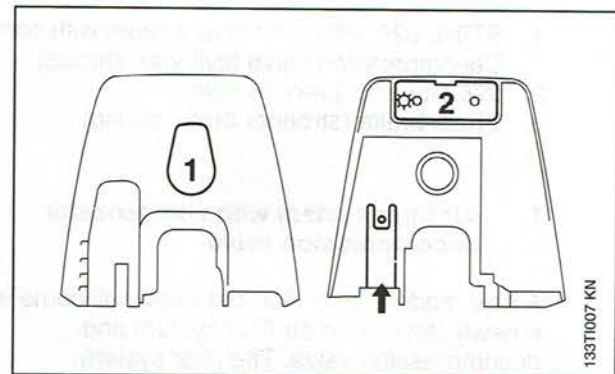

Carburetor box cover 1121 140 1904

1.2 Decompression valve

The decompression valve releases the compression in the combustion chamber during starts and thus reduces the effort required to pull the starter rope and enhances operator comfort. The valve is opened manually and closes automatically as soon as the engine begins to fire. The shroud now has an opening to accommodate the decompression valve. The area around the opening is raised (see arrow) to protect the decompression valve from accidental contact. A cover 1122 084 1405 is fitted between the cylinder and shroud to help prevent the ingress of dust and dirt.

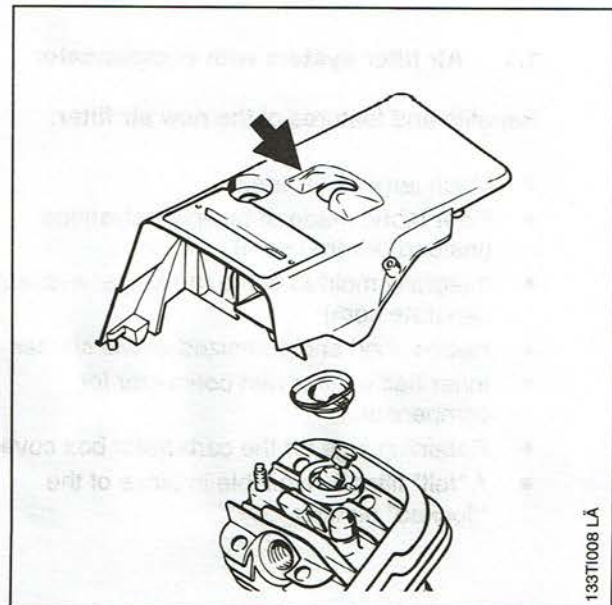

1.3 Parts availability

The original versions of the air filter and carburetor box cover remain available as replacement parts. The original end cover is supplied with the new replacement carburetor 1121 120 0650 for use in 026 saws without compensator (and for the 024). Only the new versions of the shroud and cylinder are available. If they are used for a machine without decompression valve, the opening must be sealed with the cap 1122 084 7100 provided and the tapped hole for the decompression valve sealed with the plug 1122 025 2200. The cap and plug are therefore included in the scope of supply of the new replacement parts.

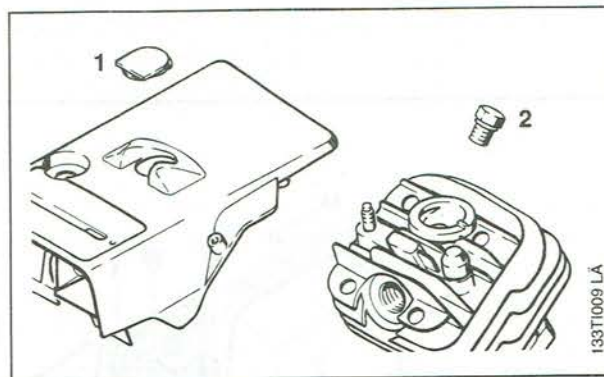

1 Cap
1122 084 7100

2 Plug
1122 025 2200

1.4 Service note

Air filter system, carburetor

The component parts of the new air filter system (air filter, carburetor with connector for compensator and carburetor box cover) may only be installed in model 026 saws from machine number X 30 976 775 and only as a complete assembly. Tank housings with a new (lower) tank vent (see TI 06.95) were installed for the first time from this machine number, and this provides sufficient space for the extra width of the new air filter. The carburetor's high and low speed adjusting screws are sealed with LOCTITE 221.

In the event of repairs to a carburetor with compensator cover, the adjusting screws must be cleaned thoroughly before installation and recoated with fresh LOCTITE 221. **Do not apply LOCTITE to the first two to three turns of the thread - under no circumstances may adhesive get into the carburetor!**

Correctly sealed adjusting screws tend to be a little difficult to turn.

Decompression valve

The decompression valve can be removed and installed with a standard deep well 13-mm socket. Tightening torque 14 Nm (10.3 lbf.ft).

To carry out the pressure test on the engine, we recommend that the decompression valve be removed and the tapped hole sealed with the plug 1122 025 2200.

Important! In case of repairs, remove the decompression valve before fitting the locking strip (to block the piston).

The new repair kit 1121 900 9004 and new intake air preheating kit 1121 007 1044 are available for models 026 "PRO" with the new air filter system.

1.5 Summary

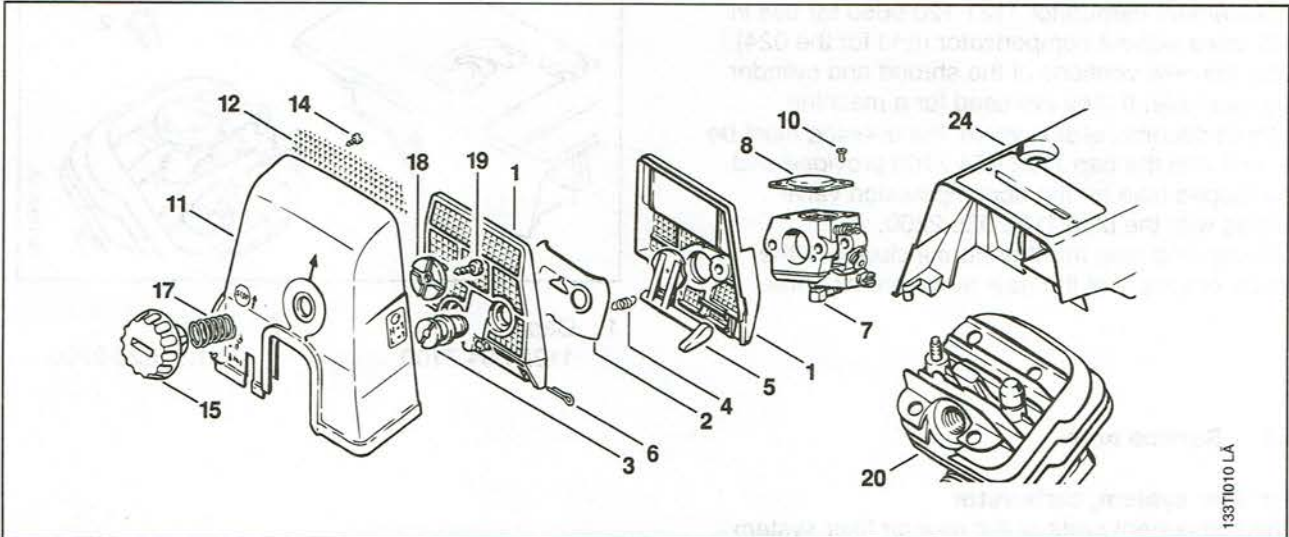

Parts of standard 026 version

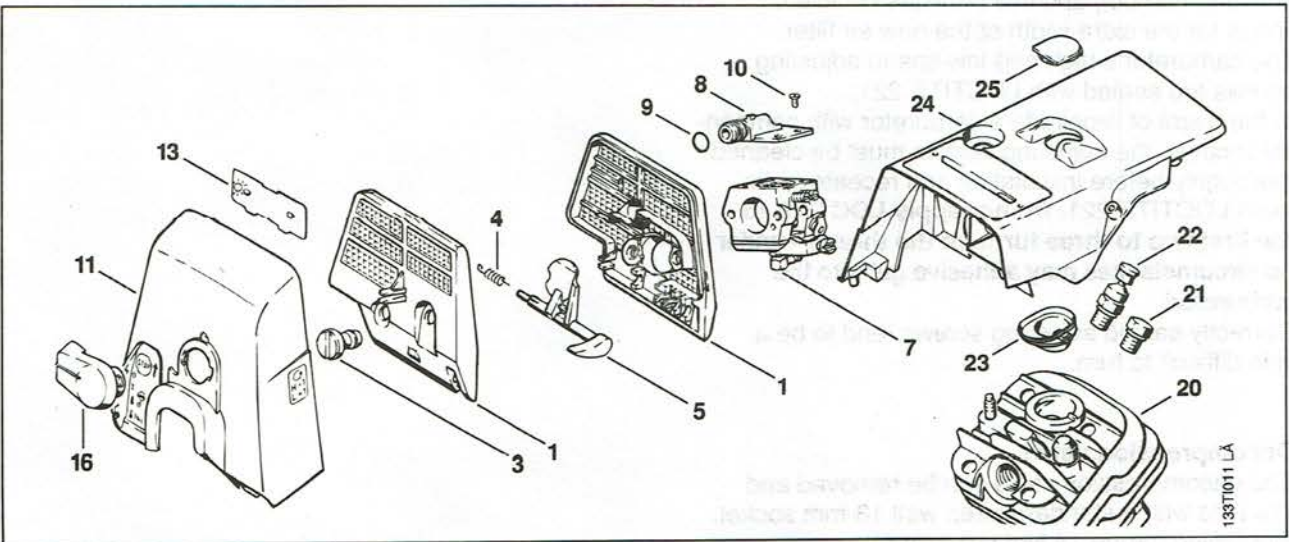

Parts of new 026 "PRO" version

Item	Part Name	Standard 026 version	New 026 "PRO" version	Rem.
1	Air filter; Air filter "flocked"; Air filter "felt"; each of above includes items 2 - 6:	1121 120 1611 1121 120 1612 ---	1121 120 1617 --- 1121 120 1618	1) 1)
2	Baffle	1121 121 7001	---	1)
3	Slotted nut	1121 141 8300	1124 141 8300	1)
4	Spring	0000 997 5505	1121 124 3000	1)
5	Choke shutter	1121 121 2900	1121 121 2905	1)
6	Split pin 2x10	9395 825 1090	---	1)
7	Carburetor; including items 8 to 10:	1121 120 0606	1121 120 0650	2)3)
8	End cover	1113 121 0800	1121 121 0810	1)
9	O-ring	---	9645 945 7485	
10	Round head screw All other parts as before	1106 122 7400	1121 122 7101	1)
11	Carburetor box cover; including items 12 to 19:	1121 140 1902	1121 140 1904	1)
12	Prefilter	1121 124 0811	---	1)
13	Cover	---	1121 141 2900	
14	Self-tapping screw B2.2x6.5	9099 021 0160	---	1)
15	Twist lock	1121 141 2300	---	1)
16	Lever	---	1130 141 2300	
17	Helical spring	0000 997 1335	---	1)
18	Detent	1121 141 2100	---	1)
19	Self-tapping screw B3.9x16	9099 021 2790	---	1)
20	Cylinder with piston; including item 21:	1121 020 1208	1121 020 1209	2)
21	Plug All other parts as before	---	1122 025 2200	
22	Decompression valve	---	1128 020 9400	
23	Cover	---	1122 084 1405	
24	Shroud; including item 25:	1121 080 1608	1121 080 1609	2)
25	Cap All other parts as before	---	1122 084 7100	
	Special accessories: Intake air preheating kit; including: Carburetor box cover All other parts as before Repair kit (ElastoStart); including item 1	1121 007 1027 1121 140 1906 1121 900 5002	1121 007 1044 1121 140 1907 1121 900 5004	1) 1) 1)

Remarks

- 1) Original version of part remains available as spare
- 2) Original version of part no longer available from factory
- 3) End cover 1113 121 0800 included in with new carburetor for use in machines without compensator

2. 026 oil pump

Before installing a new oil pump and when servicing the saw, check lubrication of the pump piston and replenish it as follows if necessary:

- Pry the plastic plug out of the pump body
- Apply a little grease to the piston control face
- Refit the plug.

3. Chain brake

A higher strength version of brake spring 1121 160 5500 will be installed from machine number X 31 103 922 to further optimize operation of the chain brake.

Summary

Item	Part Name	Original version	New version	Rem.
1	Brake spring	1121 160 5500	1121 160 5500	1)

Modification to be introduced from machine number X 31 103 922

Remarks

- 1) Only modified version of part available from factory

Last Technical Information on models 024, 026: 06.95

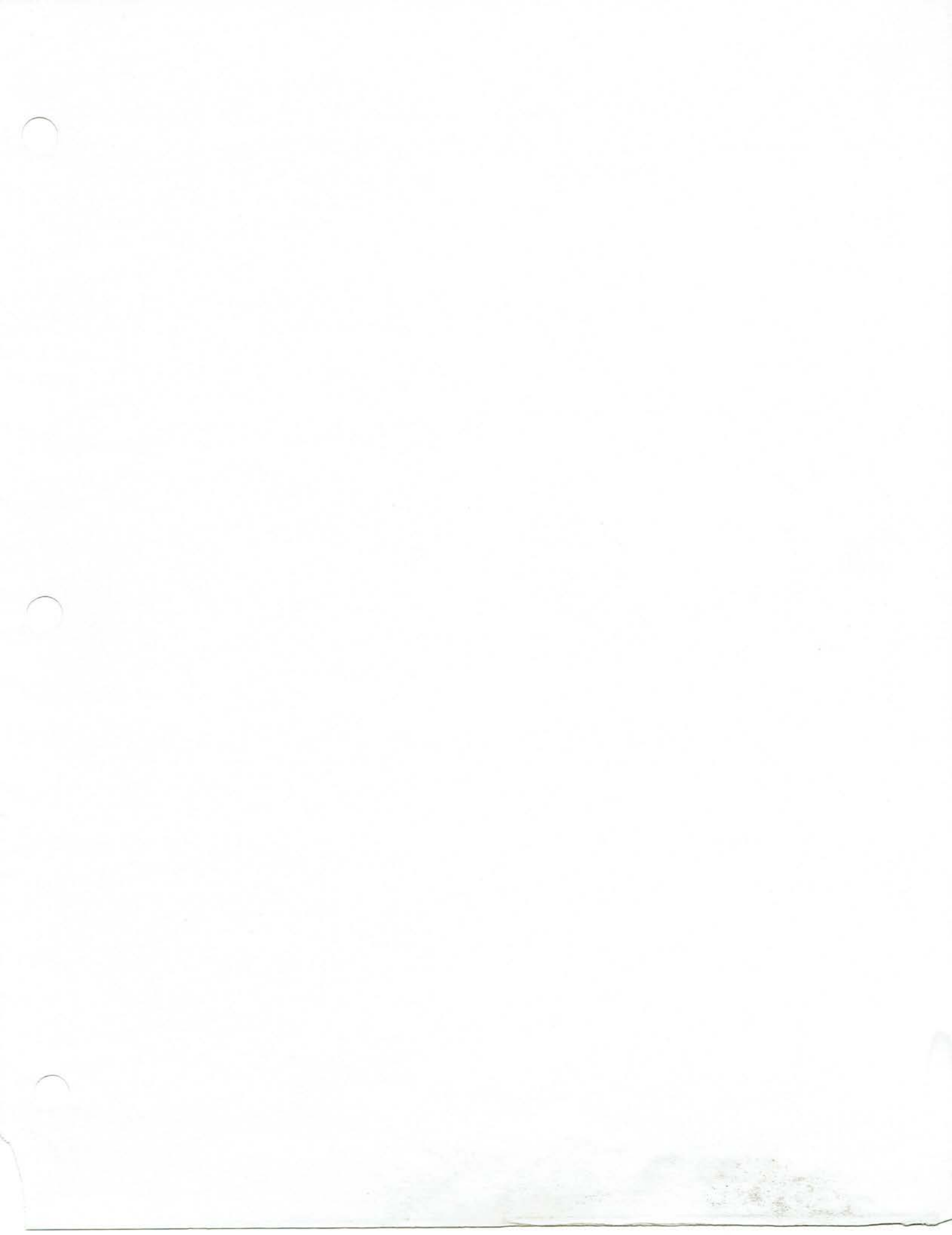

Technical Information

STIHL®

 T.20.84
 (T.14.84)

Engineering Changes on Stihl's Model 024 Chain Saws (Series 1121)

- 1) More powerful engine and two-ring piston
- 2) Annular buffer and new mounting screws
- 3) Tool kit
- 4) Support on handlebar

1. More powerful engine and two-ring piston:

Model 024 chain saws will be produced with a more powerful engine starting at machine number X 12 831 255. Design changes on the cylinder have enabled the engine's power to be increased from its previous 1.9 kW to 2.1 kW. Displacement remains unchanged.

The saw's engine will be equipped with a two-ring piston at the same time.

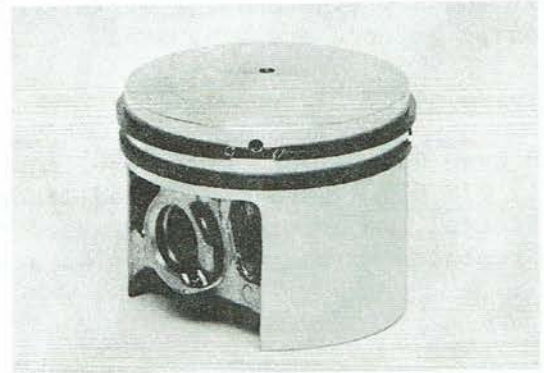

Two-ring piston

The modified parts are fully interchangeable. For this reason only, the modified versions of the cylinder and piston assembly and the piston itself, as a separate item, will be supplied as spare parts in the future. The part numbers will remain as before.

Summary:

	Original version	New version
Cylinder with piston	1121 020 1200	1121 020 1200 (no # change)
Piston	1121 030 2000	1121 030 2000 (no # change)
included with each of above:		
Piston ring	1121 034 3000 (1x)	1121 034 3000 (2x)

All other parts are as before.

2. Annular buffer and new mounting screws:

New type annular buffers will be fitted on the crankcase (bottom) in the future. They will be secured in position by pan head Screws, 9073 478 4290, instead of the previous Screws, 1121 791 6110.



Mounting screws for annular buffer
Left: Original version
Right: New version

Furthermore, the 5.5 x 19 self-tapping screws, used to spread the plugs in the two annular buffers, will be deleted in the future and replaced by pan head Screws, 9073 478 4290, which are specially designed for screw held joints in polymer materials.

Only the new type annular buffers will be supplied once factory stocks of present annular buffers are exhausted.

Service note:

Pan head Screws, 9078 478 4290, must be used, except on machines prior to serial number X 11 078 650 - with M 6 thread inserts in the tank housing, to secure the new annular buffers. The previous screws used to spread the plugs in the annular buffers should be replaced by the new screws as a matter of routine during any 024 repair.

Summary:

	Original version	New version
Annular buffer	1121 790 9905	1121 790 9906
Annular buffer	1121 790 9910	1121 790 9911
Screw	1121 791 6110 (2x)	---
Pan head screw	---	9073 478 4290 (2x)
Self-tapping screw	9100 021 4290 (2x)	---
Pan head screw	---	9073 478 4290 (2x)

3. Tool kit:

The present Combination Wrench, 1119 890 3400, in the tool kit will be deleted and replaced by Combination Wrench, 1119 890 3405. The tube of the new combination wrench is approx. 15mm (5/8 in.) longer to ease handling.

Summary:

	Original version	New version
Tool kit	1121 890 1400	1121 890 1400
including: Combination wrench	1119 890 3400	1119 890 3405

All other parts are as before.

4. Support on handlebar:

Starting with serial number X 12 991 100, a Support, 1121 791 7601, will be installed between the handlebar and tank housing on the upper handlebar mounting. The support is made of hardened sheet steel and is contoured to match the handlebar.

The support improves stability of the handlebar under extreme operating loads.



Support, 1121 791 7601

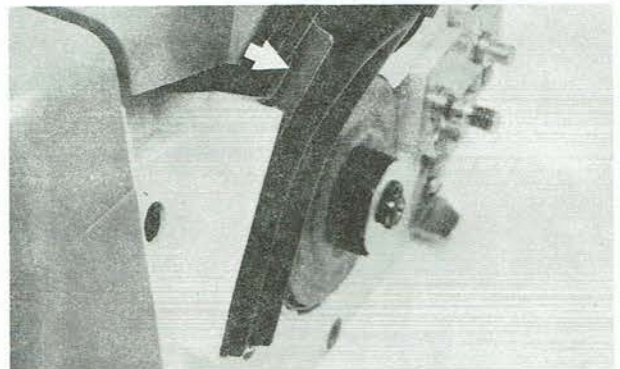

Support mounted on handlebar

Note:

The support can also be fitted to all existing model 024 chain saws.

This is done by unscrewing the upper handlebar mounting screws and pushing the support between the handlebar and tank housing to line up the holes. Then refit and tighten down the mounting screws.

Summary:

Support 1121 791 7601 new

U/TSM:tc
(684)

Technical Information

STIHL®

T.8.84
(T.5.84)

Engineering Changes on Stihl's Model 024 Chain Saws (Series 1121)

Contents:

1. Carburetor
2. Shroud mounting
3. Friction pads in chain sprocket cover
4. Replacement crankcase
5. Ignition system
6. 3/8" Picco cutting attachment for 024

1. Carburetor:

A modified version of Carburetor, 1121 120 0600, will be installed from machine number X 12 584 825. On this version, the mounting bosses, on the flange at the manifold side, are closed. This change produces a more reliable seal between the manifold and carburetor. In connection with the introduction of the modified carburetor, the Washer, 1121 121 8600, will be changed from steel to aluminum and the Gasket, 1121 129 0500, between washer and carburetor, will be deleted.

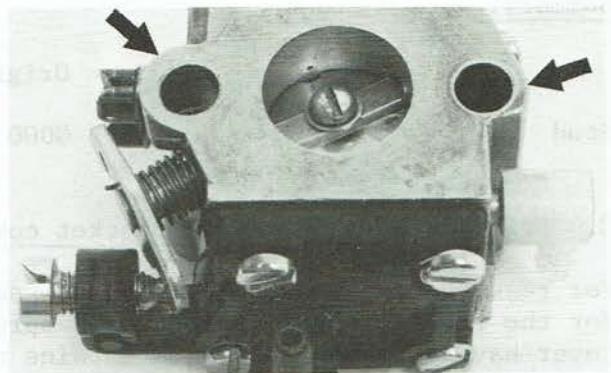

Carburetor, 1121 120 0600 (new version)

Only the modified version of the carburetor and only the aluminum washers will be supplied as spare parts in the future. The Gasket, 1121 129 0500, will remain available for original-type carburetors.

Summary:

	Original version	New version
Carburetor	1121 120 0600	1121 120 0600
Washer	1121 121 8600(steel)	1121 121 8600 (aluminum)
Gasket	1121 129 0500*	---

*Will remain available as a spare part.

Service note:

When carrying out repairs, note that the aluminum washer may only be installed in conjunction with the new-type carburetor. The steel washer and gasket should continue to be used for original-type carburetors.

2. Shroud mounting:

The two Studs, 0000 953 0800, will be replaced in the future by the Studs, 0000 953 0818, with an unthreaded tip, in order to ease positioning of the slotted nut when securing the shroud.



Stud with unthreaded tip

Summary:

	Original version	New version
Stud	0000 953 0800	0000 953 0818

3. Friction pads in chain sprocket cover:

For reasons of standardization, the seat for the friction pads in the chain sprocket cover have been modified from machine number X 12 582 925. This means that the chain sprocket cover will also be fitted with Friction Pads, 1121 648 6610. The previous Friction Pads, 1121 648 6600, will remain available as spare parts for original-type chain sprocket covers. Only the new-type chain sprocket cover will be supplied for replacement parts purposes.

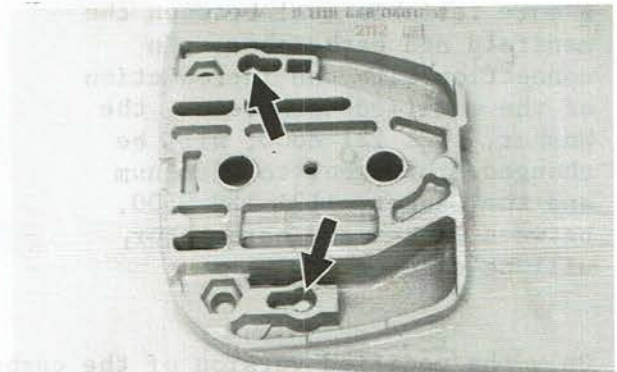

Summary:

	Original version	New version
Friction pads (for chain sprocket cover)	1121 648 6600	1121 648 6610

4. Replacement crankcase:

Only crankcases with premounted bearings will be supplied as replacement parts in the future. Crankcases without premounted bearings, which have been available up to now, will be discontinued as soon as factory stocks are exhausted.

It has been found in practice that the use of crankcases with premounted bearings offers two major advantages:

- a) Shorter repair times.
- b) Optimum factory installation of the bearings is assured by automatic degreasing, press fitting and additional bonding. This has a favorable effect on bearing life.

Summary:

	Original version	New version
Crankcase, complete (with premounted bearings) including:	---	1121 020 2103
(Crankcase (alone)	1121 020 2105	---

5. Ignition system:

The ignition system previously installed in units before serial number X 12 732 725, i.e. ignition coil and external trigger unit (hybrid construction), has been deleted. Ignition Module, 1118 400 1310, can now be used as replacement on all machine versions and will be found in all 024 series saws after the serial number noted above.

Summary:

	Original version	New version
Ignition module	1118 400 1310	1118 400 1310
Ground lead	1121 440 1100	1121 440 1100

6. 3/8" Picco cutting attachment for 024:

Model 024 chain saws can now be equipped with 3/8" Picco-Micro chain. It is necessary to change the chain sprocket for this purpose. Two rim sprocket kits (7 or 8 tooth) are available for machines with a spur sprocket. Picco rim sprockets are also available as separate items for machines already equipped with a rim sprocket. Note however, it is necessary to fit a Rollomatic guide bar with Picco pitch sprocket nose!

Summary:

Picco rim sprocket kit (7-tooth)	1121 007 1004
including:	
Clutch drum	*
Washer	0000 958 1009
Picco rim sprocket (7-tooth)	0000 642 1240
Retaining washer (8 x 1.3)	9460 624 0801
Picco rim sprocket kit (8-tooth)	1121 007 1005
including:	
Clutch drum	*
Washer	0000 958 1009
Picco rim sprocket (8-tooth)	0000 642 1241
Retaining washer (8 x 1.3)	9460 624 0801

* Not available as separate item.

U/TSM:tc

(3164)

Technical Information



T.1.85
(T.37.84)

Engineering Changes on Stihl's Model 024 Chain Saws (Series 1121):

- 1) New "Super" versions
- 2) Carburetor
- 3) Throttle trigger

1. New "Super" versions:

Model 024 chain saws are now being manufactured in larger displacement "Super" version. The increase in power has been achieved by installing a new crankshaft with a longer connecting rod stroke.

The sales designations of the Super versions will have the suffix "Super" after the letters "AV".

Example: 024 AV Super Electronic Quickstop (024 AVSEQ).

Specifications of 024 "S":

Displacement:	44.3 cm ³ (2.70 cu. in.)
Bore:	42 mm (1.65 in.) (as before)
Stroke:	32 mm (1.26 in.)
Power:	2.3 kW at 9,500 R.P.M.

Max. allowable engine speed with bar and chain: 13,000 R.P.M.

Introduction of the Super versions required the modification of several parts which have been given new part numbers (see "Summary").

On the new Crankshaft, 1121 030 0405, the distance between the centers of the crankshaft and big-end bearing is now 16 mm (0.63 in.) instead of the former 15 mm (0.59 in.). This produces a 2 mm (0.08 in.) longer stroke which, together with a modified cylinder, is responsible for the increase in engine power.

The combustion chamber portion of the new Cylinder and Piston, 1121 020 1201, was adapted to suit the longer piston stroke, i. e. raised. No changes were made to either the cylinder bore or the piston.

The new Crankcase, 1121 020 2106, with a slightly larger crank chamber, replaces Crankcase, 1121 020 2103. Only new or modified crankcases marked "S" will be supplied as spare parts in the future. Any existing stocks of the original crankcase execution can be used for all versions of the 024 with the exception of the "Super" version.

An ignition module, with two armature arms, will be installed as a standard part on the "Super" version starting with machine number X 13 837 414. Each has a plug-in HT lead for easy replacement. With the exception of the length of the HT lead, this ignition module is exactly the same as the one fitted as standard on the model 034 chain saws.

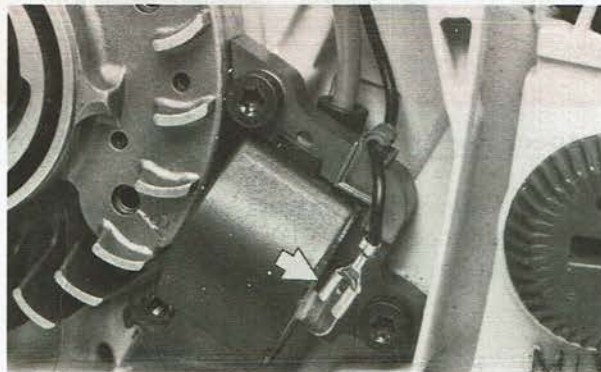

Service note:

In the interest of simplifying stockkeeping, the Ignition Module, 1125 400 1300, should be used as a replacement part on all versions of series 024, 028 and 034 saws. The lengths of the HT and ground leads have to be shortened as required when installing a replacement ignition module (see drawing).

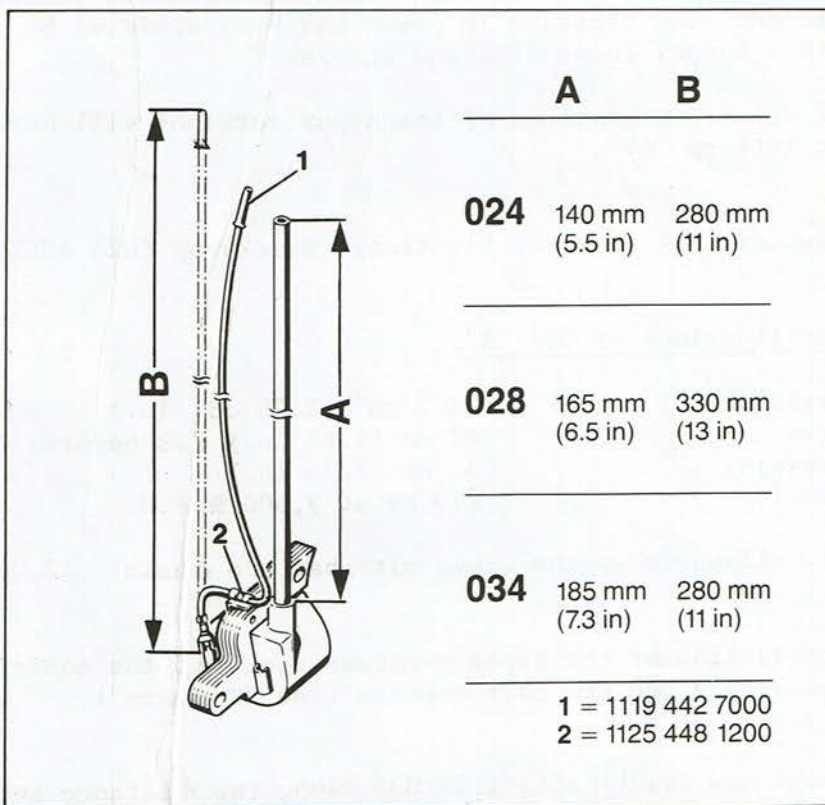

Crankshafts, 1121 030 0400 and 1121 030 0405 (for "Super"), are not interchangeable and must not be mixed up. In cases of doubt, the crankshafts can be identified by the following measurements: (see page 3)

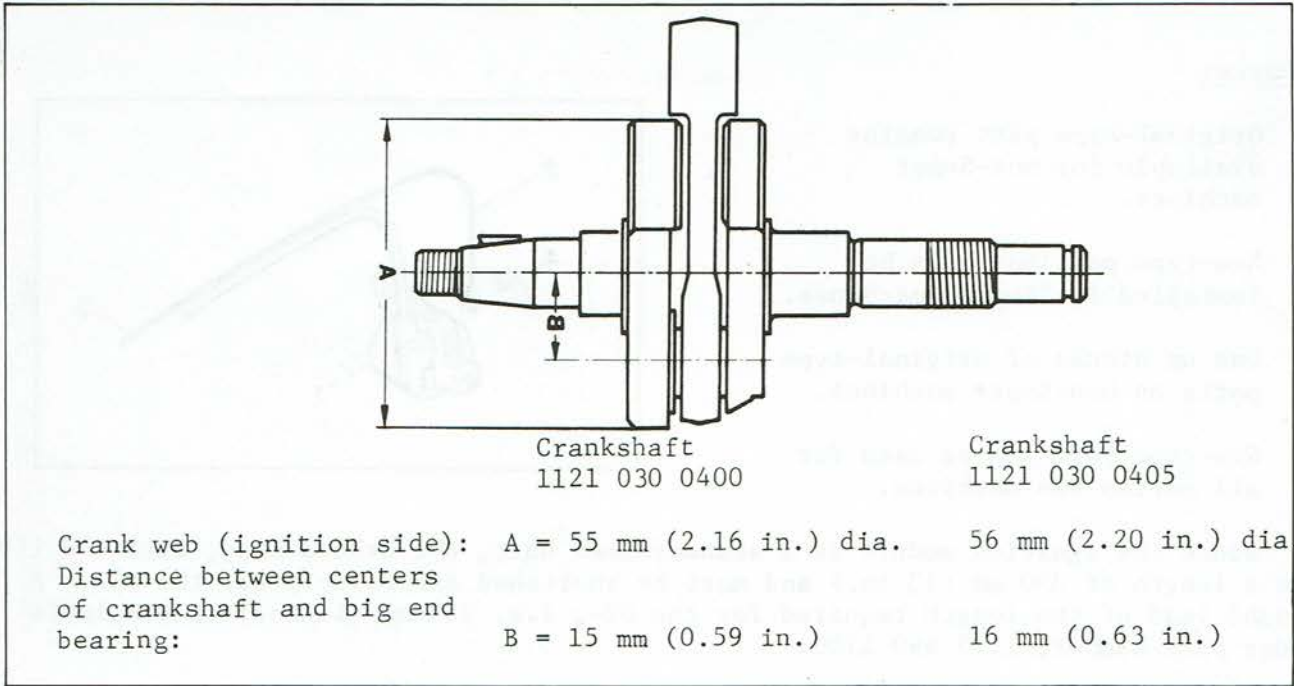

The new cylinder and piston and the new crankshaft must only be installed in "Super" machines. The crankcase on the other saw versions is not the same as the modified one, introduced for the "Super" versions.

Summary:

	Original version	New version	Key	Remarks
Crankshaft	1121 030 0400	1121 030 0405		1) 2)
Cylinder & piston	1121 020 1200	1121 020 1201		1) 2)
Crankcase	1121 020 2103	1121 020 2106		3) 4)
Ignition module including items 2 to 4	1118 400 1310	1125 400 1300	1	4)
Ground lead including item 3	1121 440 1100	1118 440 1100	2	1) 5)
Contact sleeve	---	1119 442 7000	3	
Cable retainer	---	1125 448 1200	4	
Nameplate 024 AVSEQ	---	1121 967 1502		

Remarks:

- 1) Original-type part remains available for non-Super machines.
- 2) New-type part may only be installed in "Super" machines.
- 3) Use up stocks of original-type parts on non-Super machines.
- 4) New-type part can be used for all series 024 machines.

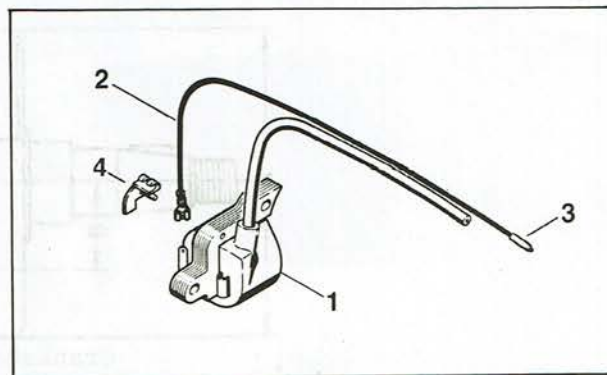

5) Since the ignition module is a standardized unit, the Ground Lead, 1118 440 1100, has a length of 330 mm (13 in.) and must be shortened accordingly for the 024. A ground lead of the length required for the 024, i.e. 280 mm (11 in.) is available under part number, 1125 440 1100.

2. Carburetor:

Two modifications will be carried out in two stages on Carburetor, 1121 120 0600. This in order to extend the idle adjustment range and the saw's running behavior when the unit is operated in unique positions. The present Throttle Valve, 1113 121 3300, will be replaced by a new one with part number, 1121 121 3305. The new throttle valve has an additional notch, opposite the existing one (which is slightly smaller than before). This modification improves running behavior when the saw is swung downward. Carburetors equipped with this throttle valve are stamped HU 54 BU by the manufacturer. Throttle Valve, 1121 121 3305, may only be installed in carburetors with the suffix "...BU" or "...C".

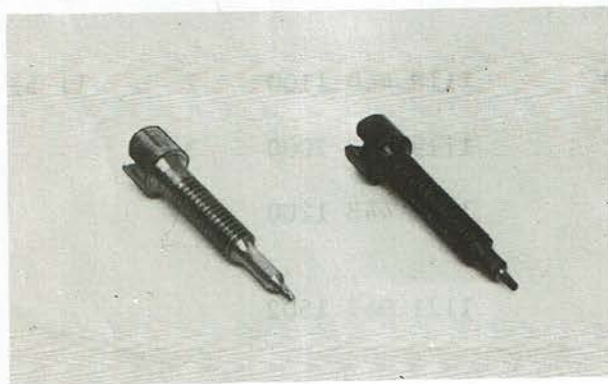

Left: Low speed Adjustment Screw, 1113 122 6800
Right: Low speed Adjustment Screw, 1121 122 6800.

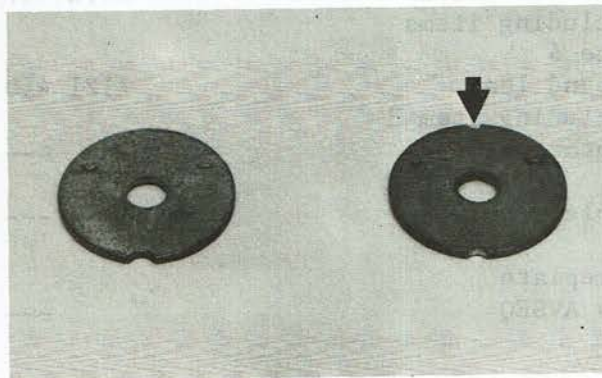

Left: Throttle Valve, 1113 121 3300
Right: Throttle Valve, 1121 121 3305

The second modification, to be introduced in the near future, is a new low speed Adjustment Screw, 1121 122 6800, to replace the present one (1113 122 6800). This new low speed adjustment screw (with a longer thread - 4 extra turns) may only be fitted in carburetor bodies marked HU 54 C, with longer adjustment screw threads to match screw. Carburetors with both the new parts mentioned above bear the designation HU 54 C.

Summary:

	Original version <u>HU 54 B</u>	Interim version <u>HU 54 BU</u>	Future version <u>HU 54 C</u>
Carburetor including: Throttle valve Low speed adjustment screw	1121 120 0600 1113 121 3300* 1113 122 6800*	1121 120 0600 1121 121 3305 1113 122 6800*	1121 120 0600 1121 121 3305 1121 122 6800

All other parts are as before.

*Remains available as a spare part.

3. Throttle trigger:

A new throttle trigger will be installed from machine number X 13 072 475. It butts against the new safety throttle lock lever in the idle position and not against the housing. For this reason, the original Throttle Lever, 1118 182 1000, and the original Lever, 1117 182 0800, have been deleted and will be supplied as spare parts only as long as factory stocks last.



Original throttle trigger and safety throttle lock.

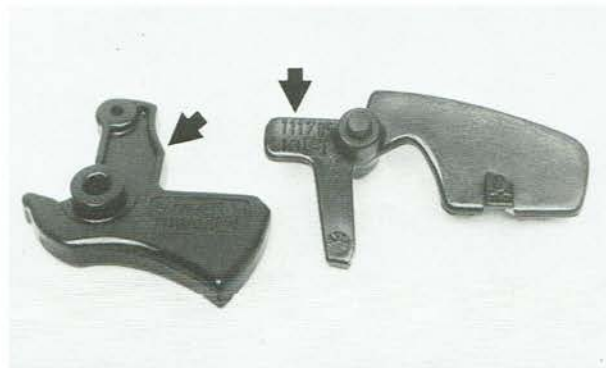

New throttle trigger and safety throttle lock.

The new and original-type throttle triggers and safety throttle lock levers are interchangeable only as assemblies. In the future, the throttle trigger will not be supplied as a separate item, i.e. it will only be available in a Throttle Trigger Set, 1118 007 1009, which includes the safety throttle lock lever. This is to ensure that the new throttle trigger is always installed with a new safety throttle lock lever. However, the safety throttle lock lever itself will be available as a separate item.

Summary:

	Original version	New version
Throttle trigger set including:	---	1118 007 1009
Throttle trigger	1118 182 1000	*
Lever	1117 182 0800	1117 182 0805

*Part not available as a separate item.

U/TSM:tc

(2155)