

# shindaiwa

## 400



This symbol on the nameplate means the product is Listed by Underwriters Laboratories Inc.

## CHAIN SAW

## OWNER'S MANUAL

**FOR YOUR OWN SAFETY, CAREFULLY READ THIS OWNER'S MANUAL BEFORE USE.**

**CAUTION:** Always wear eye protection when operating this machine.  
Your Shindaiwa 400 is equipped with spark arrestor mufflers.  
Do not run machine without spark arrestor screen in place.  
The manufacturer takes no responsibility for fire if machine is operated without this spark arrestor screen in place.



**SHIN-DAIWA KOGYO CO., LTD.**

Head Office: 35, Shin-Ujigami, Chiyoda-cho,  
Yamagata-Gun, Hiroshima, 731-15  
Japan  
Phone: 082672-6011 TLX. No. 665871SDKHIR

**Shindaiwa Inc.**

11975 S.W. Herman Road,  
Tualatin, Oregon 97062 (U.S.A)  
Phone: 503-692-3070  
TLX : 910-486-8550 SDK USA WLSV  
FAX : 503-692-6698

Designation of Parts..... 1  
Specifications..... 3  
Safety Precautions..... 4  
Kickback Safety Features..... 7  
Mounting Guide Bar and Saw Chain..... 8  
Saw Chain Adjustment..... 9  
Filling Fuel and Chain Oil..... 10  
Starting and Stopping..... 11  
Carburetor Adjustment..... 13  
Chain Brake..... 14  
Cutting..... 15  
Routine Maintenance..... 17  
Saw Chain Sharpening..... 19

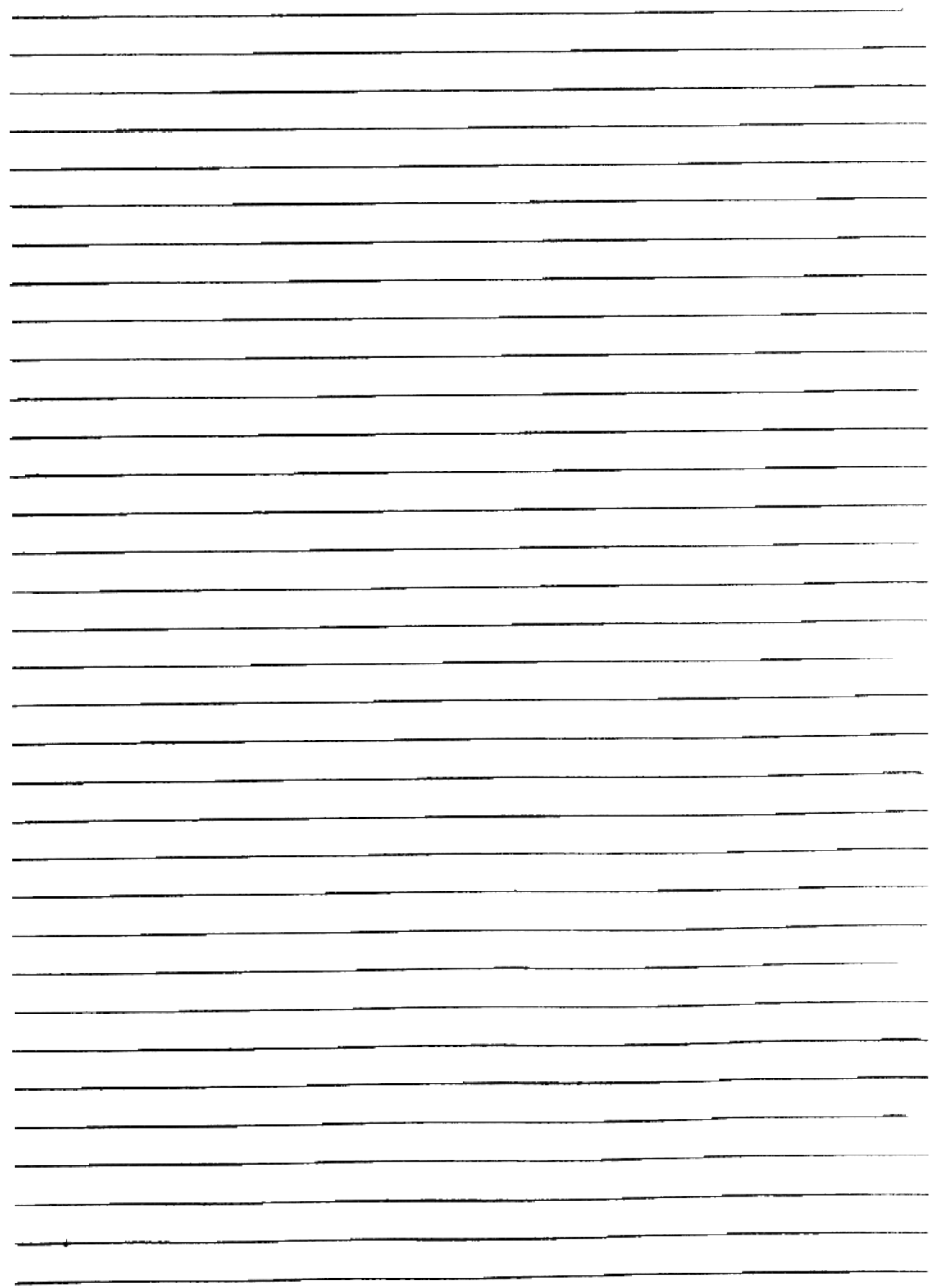

## DESIGNATION OF PARTS

2302-EV003-00

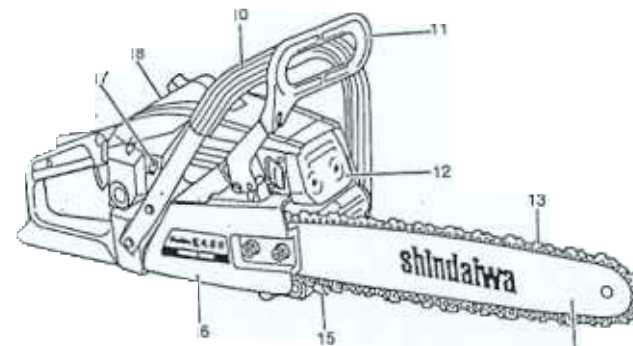
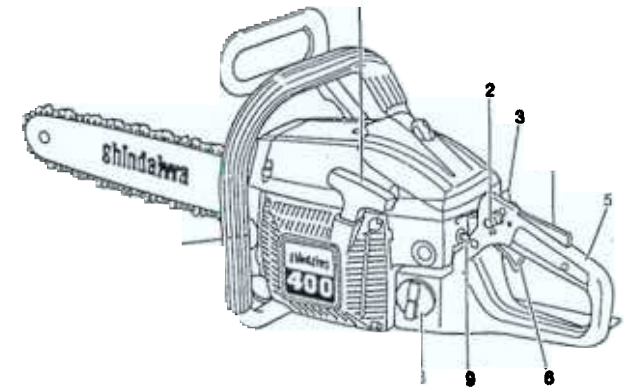

1. Recoil Starter Grip
2. Throttle Interlock Button
3. Choke
4. Lock Lever
5. Rear Handle
6. Throttle Lever
7. Chain Oil Filler Cap
8. Fuel Filler Cap
9. Engine Shut off Switch
10. Front Handle
11. Front Guard
12. Muffler
13. Saw Chain
14. Guide Bar
15. Spike
16. Clutch Cover
17. Carb. Adjustment Screws

# SPECIFICATIONS

2302-EN006-00

<b>Model</b>	<b>400</b>
<b>Engine type</b>	<b>2 cycle air cooled gas engine</b>
<b>Displacement</b>	<b>39.4 cc (39x33) (2.40 cu in)</b>
<b>Fuel</b>	<b>Gasoline-25:1 (2 cycle oil) (40:1 with premium shindaiwa brand oil)</b>
<b>Carburetor</b>	<b>Diaphragm (WALBRO) HDA79</b>
<b>Ignition</b>	<b>CDI (Capacitor Discharge Ignition system)</b>
<b>Spark plug</b>	<b>Champion CJ-6Y</b>
<b>Starting</b>	<b>Recoil starter</b>
<b>Stopping</b>	<b>Grounding (toggle switch)</b>
<b>Power transmission</b>	<b>Automatic centrifugal clutch</b>
<b>Chain lubrication</b>	<b>Automatic adjustable oiler</b>
<b>Chain</b>	<b>325 pitch, .050 gauge</b>
<b>Chain oil</b>	<b>Bar and chain oil</b>
<b>Fuel tank capacity</b>	
<b>Oil tank capacity</b>	
<b>Handle</b>	Special anti-vibration handles (front and rear handles, independently vibration dampened)
<b>Safety devices</b>	Front guard, rear guard, throttle lock and chain stop and chain brake
<b>Weight (less bar and chain)</b>	<b>4.5 kg (10.0 lb)</b>

2302-EN007-00

## Recommended Bar and Chain

	400		
Chain type	33SL (16")	33SL (18")	33SL (20")
Guide bar	16" Double-guard Sprocket nose bar	18" Double-guard Sprocket nose bar	20" Double-guard Sprocket nose bar

### Good Sharpening Examples:

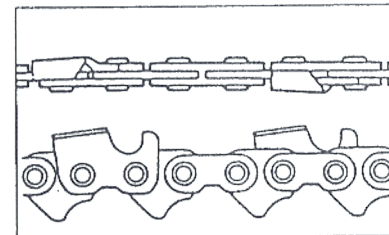

2302-EN076-00

### Wrong Filing Examples:

#### 1. Unequal cutter angles

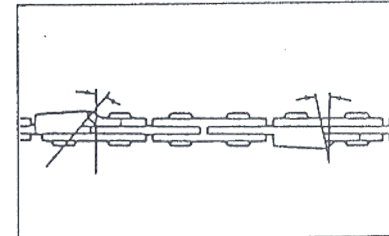

2302-EN077-00

#### 2. Unequal cutter lengths

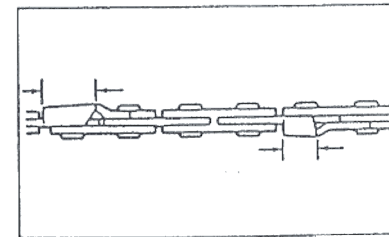

2302-EN078-00

#### 3. Inconsistent contour (caused by filing too low or too high)

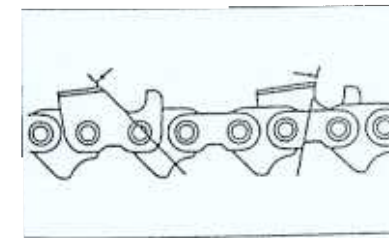

2302-EN079-00

#### 4. Unequal depth gauges

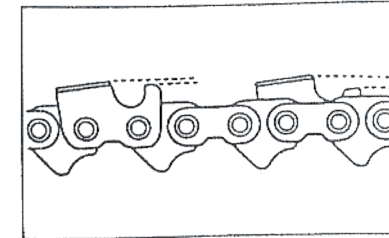

2302-EN080-00

## SAW CHAIN SHARPENING

2302-EN070-00

### 1. Designation

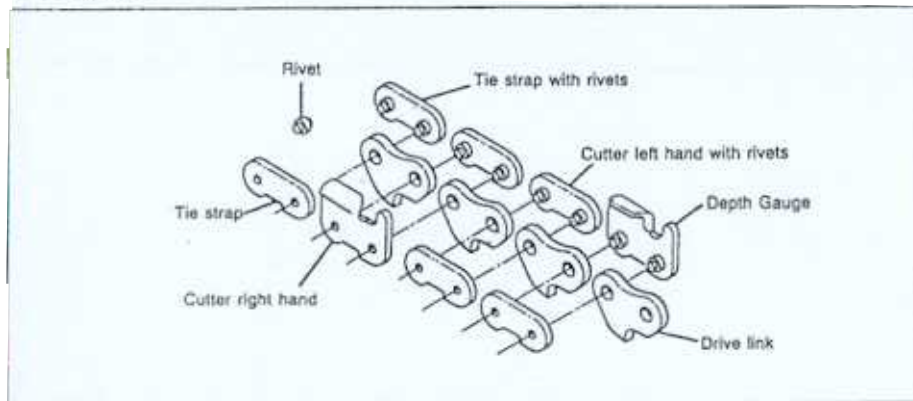

2302-EN071-00

### 2. Function

- The depth gauge controls depth or amount of cut for each tooth.
- Right and left cutters both should always be sharpened to uniform angle and depth.
- Drive links and saw chain together function to discharge sawdust.

2302-EN072-00

### 3. Points of Sharpening

- Sharpen all cutters and align right and left cutter angles to meet these specifications:

2302-EN073-00

### 4. How to Sharpen

- Sharpen right and left cutter angles uniformly to  $30^\circ$  with the round file. Unequal filing can cause erratic sawing and vibration. File in the direction as indicated with arrow.

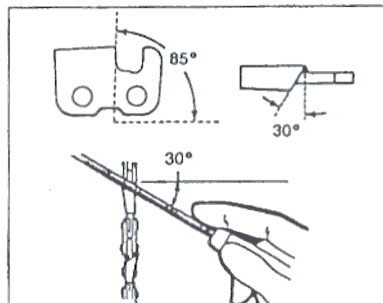

2302-EN074-00

### 5. After Sharpening

- When sharpening is completed, place the depth gauge joiner on all cutters as shown in the figure. File out  $\textcircled{A}$  portion if it is higher than the joiner. Round the filed depth gauge as shown in the illustration.

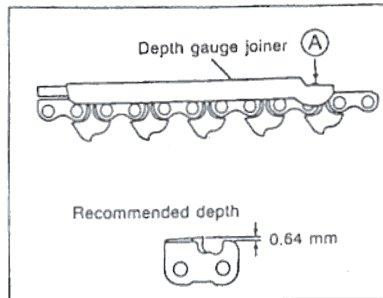

2302-EN075-00

## SAFETY PRECAUTIONS

2302-EN008-00

### IMPORTANT:

Read all instructions carefully before operating your new Shindaiwa chain saw. The following safety precautions should be observed by all users of chain saws:

- Do not operate a chain saw when you are fatigued.
- Use safety footwear; snug-fitting clothing; protective gloves; and eye, hearing and head protection devices.
- Use caution when handling fuel. Move the chain saw at least 10 feet (3m) from the fueling point before starting the engine.
- Do not start cutting until you have a clear work area, secure footing, and a planned retreat path from the falling tree.
- Before you start the engine, make sure that the saw chain is not contacting anything.
- Carry the chain saw with the engine stopped, the guide bar and saw chain to the rear, and the muffler away from body.
- Keep chain properly adjusted and sharpened.
- It is unsafe for young children and persons unfamiliar with its usage to operate any chain saw.
- When repairing or servicing, use only recommended Shindaiwa replacement parts.
- Do not operate this or any chain saw without a muffler.
  - Keep the handles dry, clean and free of oil or fuel mixture.
- All chain saw service, other than the items listed in the owner's manual maintenance instructions, should be performed by trained Shindaiwa chain saw service personnel. (For example, if improper tools are used to remove the flywheel or if an improper tool is used to hold the flywheel in order to remove the clutch, structural damage to the flywheel could occur and could subsequently cause the flywheel to burst.)

**WARNING! KICKBACK May Occur When The Nose Or Tip Of The Guide Bar Touches An Object, or When The Wood Closes In And Pinches The Saw Chain In The Cut. Tip Contact In some Cases May Cause A Lightning Fast Reverse REACTION, Kicking The Guide Bar Up And Back Towards The Operator.**

2302-EN009-00

Pinching The Saw Chain Along The Top of The Guide Bar May Push The Guide Bar Rapidly Back Towards The Operator. Either Of These Reactions May Cause You To Lose Control of The Saw Which Could Result In Serious Personal Injury. Do not rely exclusively upon the safety devices built into your saw. As a chain saw user, you should take several steps to keep your cutting jobs free from accident or injury.

13. Guard against kickback. Kickback is the upward motion of the guide bar that occurs when the saw chain at the nose of the guide bar contacts an object. Kickback can lead to dangerous loss of control of the chain saw. To reduce kickback:
  - a) With a basic understanding of Kickback, you can reduce or eliminate the element of surprise. Sudden surprise contributes to accidents.
  - b) Keep a good firm grip on the saw with both hands, the right hand on the rear handle, and the left hand on the front handle, when the engine is running.  
Use a firm grip with thumbs and fingers encircling the chain saw handles. A firm grip will help you reduce kickback and maintain control of the saw. Don't let go.
  - c) Only use replacement bars and chains specified by the manufacturer or the equivalent.
  - d) Hold the chain saw firmly with both hands.
  - e) Do not overreach.
  - f) Do not let the nose of the guide bar contact a log, branch, ground, or any other obstruction.
  - g) Cut at high engine speeds.
  - h) Do not cut above shoulder height.
  - i) Follow manufacturer's sharpening and maintenance instructions for the saw chain.
  - j) Use devices, such as low-kickback chain, chain brakes, and special guide bars, that reduce the hazards associated with kickback.
14. When transporting your chain saw, use the appropriate guide bar scabbard.
15. Do not allow other persons to be near the chain saw when starting or cutting with the chain saw. Keep bystanders and animals out of the work area.
16. Hold the chain saw firmly with both hands, the right hand on the rear handle and the left hand on the front handle, when the engine is running. Use a firm grip with thumbs and fingers encircling the chain saw handles.

**Spark Plug Inspection.**  
Remove spark plug and clean it, then adjust the gap. Optimum clearance- 0.6mm (.024").

Model 400....Champion CJ-6Y.

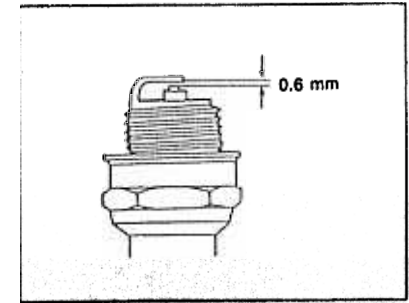

2302 EN088-00

**Sprocket Inspection.**  
Check rim (which drives chain behind clutch drum) after removing clutch cover. If there is any wear on sprocket, replace it with a new one.

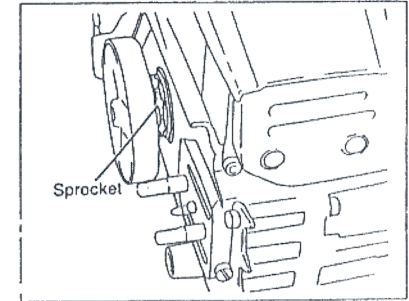

2302 EN069-00

## ROUTINE MAINTENANCE

2302-EN060-00

### 1. Saw Chain-

Saw chain sharpness is essential in determining its performance. When cutter is in worn state, sharpen it at once. Cutting with a dull chain increases fatigue and greatly lowers cutting performance. When dirty due to grease or pitch, wash with gasoline and immerse in oil to prevent rust.

2302-EN061-00

### 2. Guide Bar-

Always clean the saw bar groove and oil hole. When they are clogged with chips, remove them. For distribution of wear (and increased life), occasionally turn bar over.

2302-EN062-00

### 3. Air Filter-

Remove air filter, being careful not to drop dust in carburetor, and rinse with gasoline or solvent. When blowing with air, blow from inside filter. After cleaning, slide air filter securely back in place.

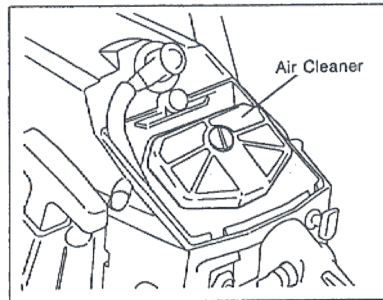

2302-EN063-00

### 4. Periodical Inspection and Maintenance- Cylinder Fin Cleaning.

Dirt or dust clogged fins can cause engine overheating. Clean between cylinder fins. When heavily clogged, cleaning should be made after removing recoil case.

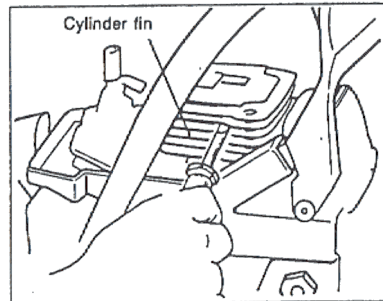

2302-EN065-00

### Fuel Filter.

Take off filter with the use of a wire hook through tank opening. Remove both filter elements and rinse them well with gasoline.

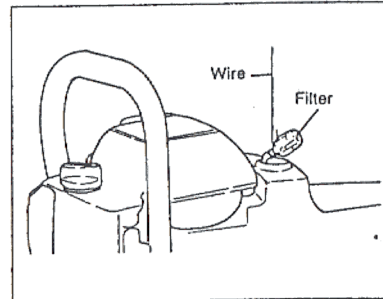

2302-EN066-00

7. Keep all parts of your body away from the saw chain when the engine is running.
18. Do not operate a chain saw that is damaged, is improperly adjusted, or is not completely and securely assembled. Do not run without clutch cover installed. Be sure that the saw chain stops moving when the throttle control trigger is released.
19. Shut off the engine before setting it down.
20. Use extreme caution when cutting small size brush and saplings because slender material may catch the saw chain and be whipped toward you or pull you off balance.
21. When cutting a limb that is under tension, be alert for springback so that you will not be struck when the tension in the wood fibers is released.
22. Operate the chain saw only in well-ventilated areas.
23. Do not operate a chain saw in a tree unless you have been specifically trained to do so.
24. Open fuel cap slowly to release any possible build-up of pressure. Do not refuel a hot saw. Allow to cool if possible.
25. Operation of a chain saw with faulty or damaged antivibration mounts (isolators) can lead to higher vibration. Long-term vibration can cause damage to the operator's hands. For lowest vibration, replace damaged mounts immediately. Mounts hardened due to age or weathering should also be replaced.
26. Prolonged exposure to excessive noise is fatiguing and could lead to impaired hearing. The use of proper ear protection can reduce this potential hazard.

### Note:

These safety precautions are intended primarily for the consumer or occasional user.

When using a chain saw for logging purposes, refer to the Code of Federal Regulations, Section 1910. 266 (5); 2.5.1 of American National Standard Safety.

Requirements for Pulpwood Logging, ANSI 03.1—1978; and relevant state safety codes.

## KICKBACK SAFETY FEATURES

2302-EN011-00

This chain saw is equipped with the following safety equipment:

- Chain brake
- Low kick chain
- Guard-tip bar

The chain brake activates (causing a band to stop chain movement) when sufficient kickback energy is present for the operators' hand to contact the brake lever.

Proper adjustment is essential.

See page 14 for instructions.

### CAUTION:



Do not use a replacement saw chain unless it is designated or labeled as meeting ANSI B175.1 Kickback performance requirements for this model, or has been designated as "low-kickback chain" in accordance with the ANSI B175.1 standard.

**Low Kick Chain** — Significantly reduces the rotational force of kickback, if used conjunction with an approved bar, chain and saw combination.

**Guard Tip Bar** — A guide bar with a much smaller nose radius, to lower the overall kickback zone.

### NOTE:

To reduce the risk of kickback, all of the above must be in good repair.  
Use of other than ANSI B175.1 combinations may produce much greater kickback energy.

Low-kickback saw chain is chain which has met the kickback performance requirements of ANSI B175.1 (safety requirements for gasoline-powered chain saws) when tested on the representative sample of chain saws below 3.8 c.i.d specified in ANSI B175.1.

- b. When cutting a log supported on both ends, begin from the top side by cutting down, 1/3 of the way through the log, and finish by coming up from the bottom. This prevents pitching of the guide bar.

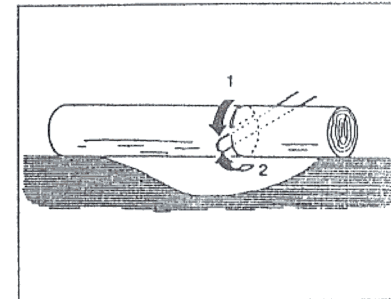

2302-EN059-00

- c. Limbing of standing tree. Cut 1/3 from the underside first, then cut through from the top. Thus easy limbing can be attained by cutting the remaining part flush with the trunk of the tree.

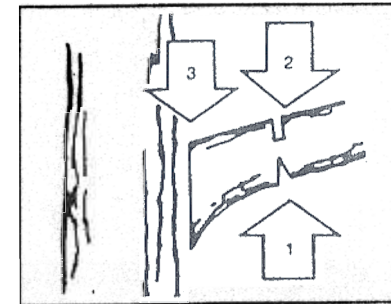

2302-EN059-00



## CUTTING

2302-EN003-00

1. Before Starting-
  - a. Understand safety procedures.
  - b. Clear a safe work area.
  - c. One should wear safety helmet, protective wear for hands and feet, and close fitting but comfortable clothes.
  - d. When moving from place to place, stop engine for safety.
  - e. Always keep saw chain tensioned properly and inspect often.
  - f. Check for loose bolts and nuts before use.

2302-EN003-00

2. Efficient Operation-

Wood can be cut most efficiently by light pressure and with saw rpm in the 9,000-10,000 rpm range at full throttle.

2302-EN004-00

### NOTE:

High pressure against wood lowers engine rpm, increases fatigue, and lowers cutting performance, resulting in considerable efficiency loss.

2302-EN005-00

3. Felling a Tree-
  - a. Determine the direction of fall, considering size, shape and lean of tree.
  - b. Clean around area for safe operation.
  - c. Cut a notch about 1/3 of the diameter of the tree.
  - d. The felling cut is horizontally made on the side opposite to the notch and at a level about 5 cm (2") above the bottom notch. The remaining wood between notch cut and felling cut (about 3 to 5 cm - or 1" to 2") will act as a hinge and tree will fall in the direction of the notch. If pinching of the bar should occur during cutting, remove chain saw (with engine stopped) by the use of a wedge.
  - e. When tree begins to fall, stop engine and give a signal to others in the area. Remember: Falling direction is not always the one desired!

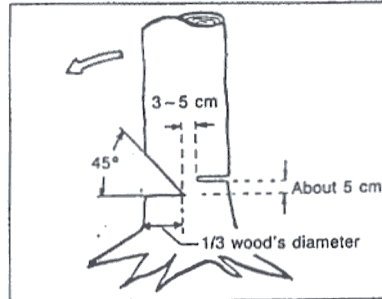

2302-EN056-00

4. Bucking and Limbing-
  - a. For wood lying on the ground, use caution as to its stability. On a slope, always stand and work uphill to the log. Start cutting from the top of the log. Cut with repeating level action using saw spike as a fulcrum. Do not cut into dirt!

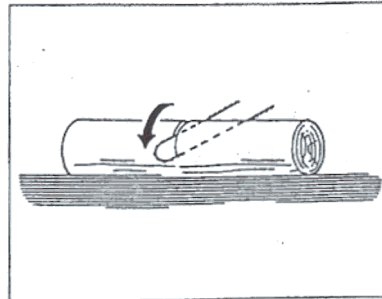

2302-EN057-00

## MOUNTING GUIDE BAR AND SAW CHAIN

2302-EN013-00

1. Remove two nuts, clutch cover, guide plate and spacer.
2. Install guide bar.
3. Fit saw chain first from sprocket side, then into guide bar groove toward bar tip.
4. Insert bar adjusting stud into the hole of guide bar, pulling forward the guide bar.
5. Install clutch cover, secure it temporarily with two nuts. Now saw chain adjustment operation begins.

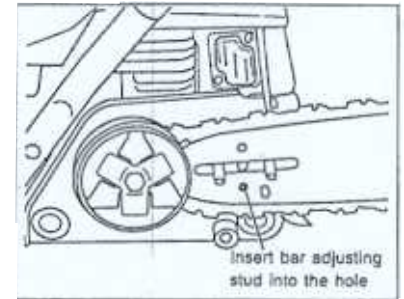
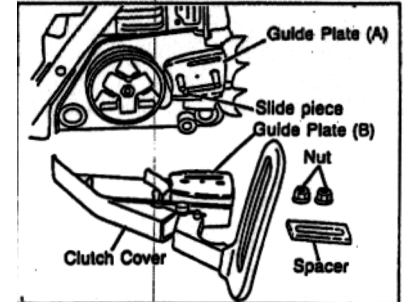

2302-EN014-00

## SAW CHAIN ADJUSTMENT

2302-EN015-00

Correct saw chain tension is essential to achieve maximum performance for chain life, cutting ability, and safety. Whenever using a new chain, it is advisable to soak it in oil overnight before use and to check the chain tension from time to time because it can stretch initial operation.

2302-EN016-00

### 1. Proper Chain Tension:

To properly adjust tension, first lift bar nose to remove slack between bar mounting slot and bar stud. For hard nose bars, adjust until a slight pulling pressure on chain at mid-bar will leave 3-3.5mm (+-1/8") gap between bar rail and chain side plate. (See illustration) For sprocket nose bars, adjust slightly tighter, still allowing chain to pull around bar freely.

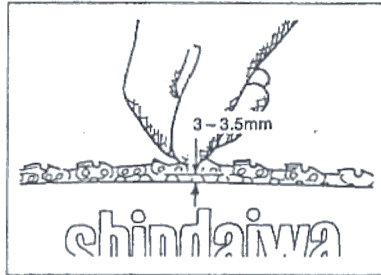

2302-EN017-00

### CAUTION:

Loosely tensioned chain can cause unexpected accidents and lead to excessive bar and chain wear. Always check before use.

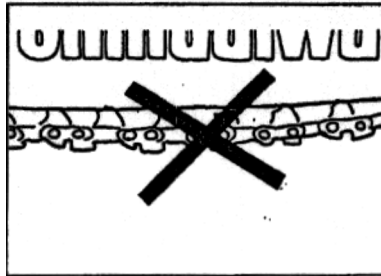

2302-EN018-00

### 2. To Adjust:

- Loosen clutch cover nuts about one turn.

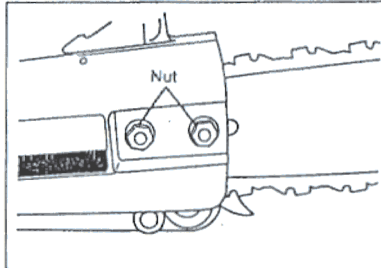

2302-EN019-00

- Turn slide screw with screw driver. Turn to right (clockwise) to tighten, and left (counter-clockwise) to loosen.

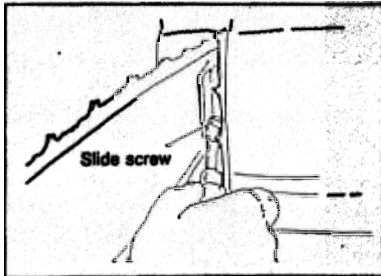

2302-EN020-00

## CHAIN BRAKE

2302-EN044-00

Model 488 is equipped with a chain brake. If kickback should occur, chain brake will stop saw chain rotation when brake lever hits operator's hand.

2302-EN045-00

### 1. Chain Brake Operation-

- Chain brake will release saw chain when in vertical position. (Position 1)
- Chain brake will actuate and lock saw chain when brake lever is in forward tilted position. (Position 2)
- When you want to release brake, pull brake lever back to vertical position. (Position 1)

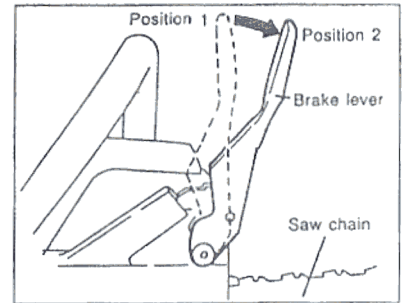

### NOTE:

Upon actuating chain brake you should release throttle lever.

### 2. Chain Brake Adjustment-

Lay down brake lever to Position 2. Adjust adjusting screw with straight blade screwdriver (-) as follows.

- Tighten adjusting screw so that saw chain will not rotate by hand when brake lever is raised in vertical position. (Position 1)
- Loosen and adjust adjusting screw about 2 to 4 times from this position so that saw chain is rotatable with lever in vertical position. (At this point make sure that brake band is not contacting clutch drum.)

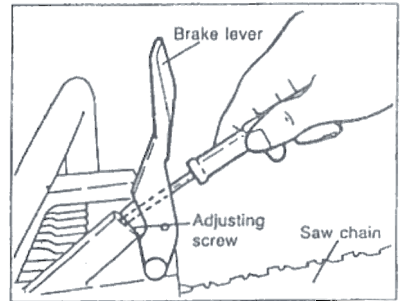

2302-EN047-00

### NOTE:

Always stop engine during chain brake adjustment.

2302-EN048-00

- After adjustment of chain brake, start engine and make brake actuating test and adjust as necessary. To tighten chain brake, turn adjusting screw to the right.

2302-EN049-00

### 3. Maintenance of Chain Brake-

- Always keep chain brake clean, free of sawdust and debris.
- Periodically check that brake band does not interfere with clutch drum when chain brake is not actuated. (If there is interference, adjust in accordance with item 2.)

2302-EN050-00

### CAUTION:

- Never start and operate engine with chain brake actuated (chain stopped).
- Always carry chain saw by its front handle (never carry by chain brake lever).
- Be sure that brake lever is in vertical position (set state) during assembly and removal of chain brake
- The purpose of the chain brake is to minimize kickback danger, not to protect from careless usage
- Readjust carburetor if its adjustment was made while chain brake was actuated.

2302-EN051-00

## CARBURETOR ADJUSTMENT

2302-EN038-00

With engine running, adjust carburetor using the following procedures:

### 1. Idle Screw Adjustment-

Turn idle adjusting screw so that stable operation can be obtained at 2,600 to 3,000 rpm.

Note: Turning adjusting screw clockwise increases rpm. (Saw chain must not turn at above rpm.)

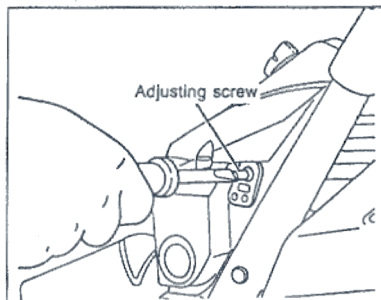

### 2. Low Speed (L) and High Speed (H) Adjustment-

Standard opening:

L ..... 1-1/4 ± 1/4 turns

H ..... 1-1/4 ± 1/4 turns

"Standard opening" means number of turns from the fully closed position by turning needle gently counter-clockwise.

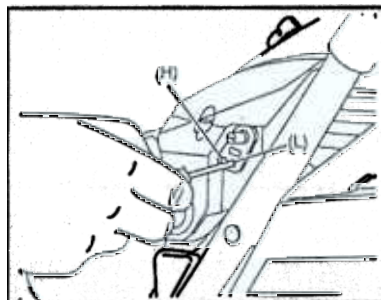

### 3. Adjustments for Low Speed (L) Adjustment Screw-

After adjusting according to item 2, continue to turn gently either to right or to left so that engine rotation may be increased. Continuing further to turn will result in engine rpm decrease. Return to the position just before this slowdown and set at this point. Next, as idle speed is considerably higher than in the case of item 1 setting, reset idle adjusting screw so that engine idles at 2,600 to 3,000 rpm. By repeating this procedure two to three times, optimum low speed idle adjustment can be obtained.

2302-EN041-00

### 4. High Speed (H) Adjustment-

No adjustment is necessary when the saw is new. After approximately 10 hours running time, readjust the H-needle to 1-1/4 turns (+ 1/4 turns).

2302-EN042-00

## CAUTION

1. Do not run saw at full throttle with no load. If run in this condition, seizure can occur.
2. Do not adjust H - needle to less than 1 turn. If run at less than 1 turn, seizure can occur.
3. Do not exceed 13,500 RPM.

2302-EN043-00

## FILLING FUEL AND CHAIN OIL

2302-EN047-00

### 1. Fuel Mixture:

Always use a gas/oil ratio of 25 : 1. (40 : 1 with premium Shindaiwa brand oil)

2302-EN022-00

### 2. Chain Oil:

This oil performs an essential role to reduce guide bar and chain wear, and to facilitate smooth cutting. Always use clean oil and refill when refueling.

## NOTE:

During cold weather, it may be necessary to thin chain oil by mixing one part oil to one part kerosene to improve lubrication.

2302-EN023-00

### 3. Automatic Oiler:

The automatic oiler is designed to operate only when the chain is operating.

To adjust the automatic oiler, which leaves the factory at Min. position, turn to the left (counter-clockwise) to increase flow and to the right (clockwise) to decrease flow. A temporary increase in flow may be necessary in cutting hardwood or large diameter softwood. When work is finished, adjust oiler to Min. position again.

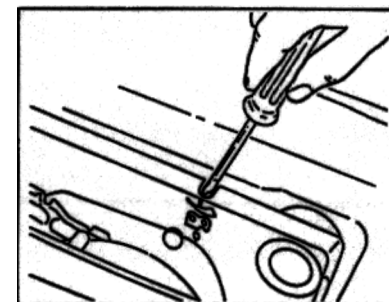

2302-EN024-00

**CAUTION:**

Before starting, clear a safe work area. When the engine starts, the chain will rotate, so be prepared!

**1. Starting:**

**a. When engine is cool-**

- 1) Turn switch "ON"
- 2) Pull choke lever all the way out.
- 3) Depress lock lever ①, then push starting throttle lock ③ into throttle lever ②.  
Then release throttle lever ②.

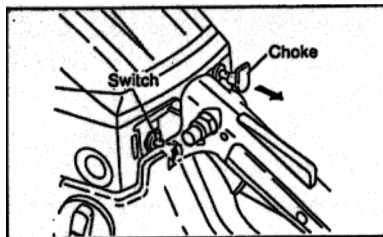

**b. When engine is warm-**

- 1) Set switch "ON"
- 2) Depress lock lever ①, then push starting throttle lock ③ into throttle lever ②.  
Then release throttle lever ②.

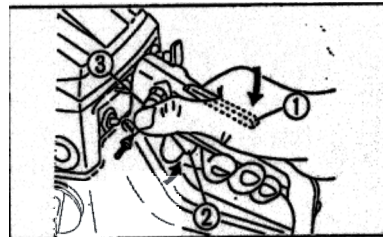

**NOTE:**

Throttle lever cannot be pulled without depressing lock lever ① in upper handle. When throttle is released, idle speed is resumed, and chain rotation stops.

- 3) Pull recoil starter rope while holding the chain saw firmly and placing your right foot into rear handle as shown in the illustration. Pull cord slowly until engaged, then rapidly after you can feel the increased resistance.

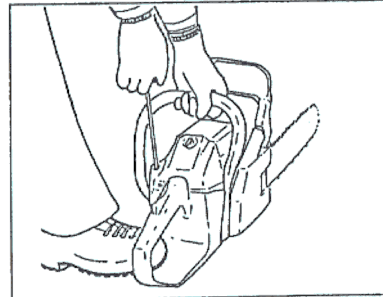

**CAUTION:**

Don't pull rope to its full length and do not let your hand slip off the rope when it is under tension. Starting can be easily attained by pulling vigorously from the engaged position.

- 4) When engine fires or coughs, press choke into the original position and pull recoil starter again. Use caution as chain will rotate during engine starting. After brief revving of engine to clear carburetor, saw will idle with throttle lock off. If saw fails to start after a few pulls, follow above procedures from the beginning. If saw still will not start, flooding may have occurred so check as follows:

- (a) Check spark by removing spark plug and shorting against cylinder while pulling recoil starter rope. Make sure switch is "ON".

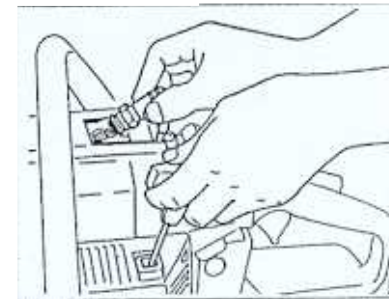

- (b) Inspect to see if spark plug is fouled after removing plug. If fouled: 1) Expel fuel by hand cranking several times without spark plug. 2) Wipe off excess fuel from plug and reset plug before starting engine.

**NOTE:**

1. Make sure switch is "ON" before starting.
2. Return choke to the original position when saw first fires when starting with full choke. (Otherwise flooding will result and engine won't start.)
3. Upon starting, allow saw to idle for 1 to 2 minutes for warm-up.

**2. Stopping:**

Turn switch "OFF" after idling at low speed for 1 to 2 minutes.

**CAUTION:**

1. Do not mix fuel or refuel saw around fire or flame.
2. Don't smoke while refueling or mixing fuel.
3. Always use a mixing ratio of 25 : 1 (40 : 1 with premium shindaiwa brand oil)
4. Don't use dirty or reclaimed oil.