

shindaiwa



This symbol on the nameplate means the product is Listed by Underwriters Laboratories Inc.

575 575W 575G CHAIN SAW

OWNER'S MANUAL

FOR YOUR OWN SAFETY, CAREFULLY READ THIS OWNER'S MANUAL BEFORE USE.

SHIN-DAIWA KOGYO CO., LTD.

Head Office: 35, Shin-Ujigami, Chiyoda-cho,
Yamagata-Gun, Hiroshima, 731-14,
Japan
Phone: 082672-6011 TLX. No.665871 SDKHIR

Shindaiwa Inc.

11975 S.W.Herman Road,
Sherwood, Oregon 97140 (U.S.A)
Phone 503-692-3070
TLX 910-466-8850 SDK USA

Printed in Japan

CAUTION: Your Shindaiwa 575, 575W and 575G Chain Saw are equipped with spark arrestor muffler.
Do not run without spark arrestor screen in place.
The manufacturer takes no responsibility for fire if run without spark arrestor screen.

TABLE OF CONTENTS

Designation of	
Specifications	
Safety Precautions	
Kickback Safety	
Mounting Wrap Handle	
Mounting Guide	Chain
Saw Chain Adjustment	10
Filling Fuel Chain Oil	
Starting and Stopping	
Carburetor Adjustm	
Heated Handle	
Chain	
Cutting	
Routine Mai	20
Saw Chain Sharpening	

MEMO

DESIGNATION OF PARTS

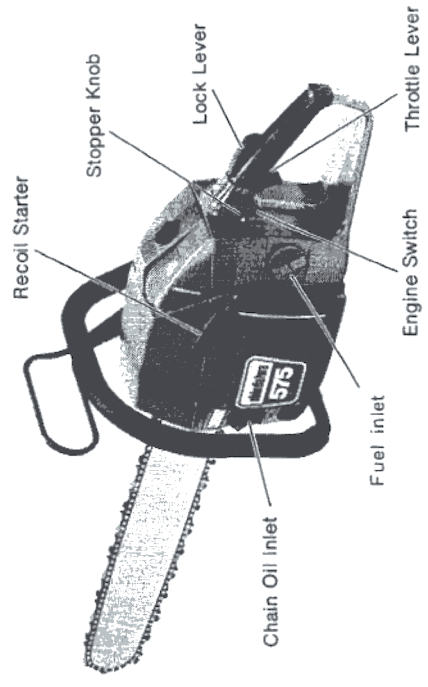
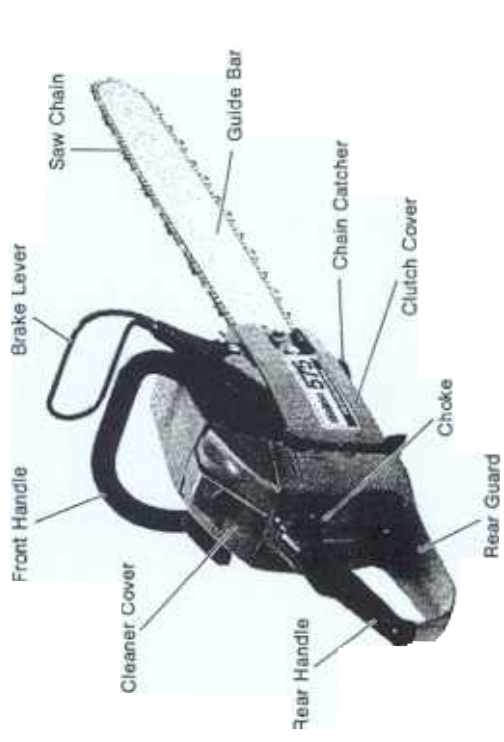

(Picture shows Model 575)

SPECIFICATIONS

Model	575, 575W, 575G
Engine type	2 cycle air cooled gas engine
Displacement	57.3cc (45X36) (3.50cu.in)
Fuel	Gasoline—25 : 1 (2 cycle oil) (or 40 : 1 premium shindoh brand oil)
Carburetor	Diaphragm (WALBRO) HDA50A
Ignition	Capacitor discharge ignition system (CDI)
Spark plug	Champion CJ6Y
Starting	Recoil starter
Stopping	Grounding (toggle switch)
Power transmission	Automatic centrifugal clutch
Chain lubrication	Automatic adjustable oiler
Chain	3/8" pitch, gauge 0.068"
Chain oil	Motor oil SAE 10W-30
Fuel tank capacity	0.7 liter
Oil tank capacity	0.33 liter
Handle	One piece anti-vibration handle.
Cooling system	Forced-air
Safety devices	Front guard, rear guard, throttle lock and chain stop and chain brake
Weight (less bar and chain)	575 : 6.9 kg 575W : 6.1 kg 575G : 6.1 kg

RECOMMENDED BAR AND CHAIN				
For Consumer 575, 575W, 575G				
Chain Type	77SLO-60X (16")	77SLO-68X (18")	77SLO-72X (20")	77SLO-84X (24")
Guide Bar	16" Guard Tip Sprocket Nose Bar 7961B-16	18" Guard Tip Sprocket Nose Bar 7962B-18	20" Guard Tip Sprocket Nose Bar 7963B-20	24" Guard Tip Sprocket Nose Bar 7960B-24
For Professional * 575, 575W, 575G				
Chain Type	77SLO-60X (16")	77SLO-68X (18")	77SLO-72X (20")	77SLO-84X (24")
Guide Bar	16" Symmetrical Sprocket Nose Bar 7961D-16	18" Symmetrical Sprocket Nose Bar 7962D-18	20" Symmetrical Sprocket Nose Bar 7963D-20	24" Symmetrical Sprocket Nose Bar 7960D-24
Chain Type	34SLO-68X 16"	34SLO-78X 18"		
Guide Bar	16" Symmetrical Sprocket Nose Bar 8843C-16	18" Symmetrical Sprocket Nose Bar 8844C-18		
* The professional bar/chain combinations as listed above do meet ANSI B175.1-1985 kickback regulations when used on the model 575. As lower kickback combinations are available, these 77SL/symmetrical nose bar and 34SL/symmetrical nose bar combinations are recommended for professional use only. Guard Tip bars with 77SL chain are recommended for consumer use.				

Good Sharpening Examples:



Wrong Filing Examples:

1. Unequal cutter angles



2. Unequal cutter lengths

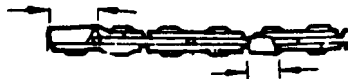

3. Inconsistent contour (caused by filing too low or too high)

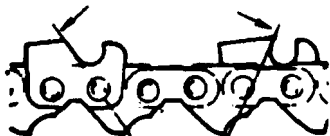

4. Unequal depth gauges



SAFETY PRECAUTIONS

IMPORTANT:

Read all instructions carefully before operating your new Shindaiwa chain saw.

The following safety precautions should be observed by all users of chain saws:

1. Do not operate a chain saw when you are fatigued.
2. Use safety footwear; snug-fitting clothing; protective gloves; and eye, hearing and head protection devices.
3. Use caution when handling fuel. Move the chain saw at least 10 feet (3m) from the fueling point before starting the engine.
4. Do not start cutting until you have a clear work area, secure footing, and a planned retreat path from the falling tree.
5. Before you start the engine, make sure that the saw chain is not contacting anything.
6. Carry the chain saw with the engine stopped, the guide bar and saw chain to the rear, and the muffler away from body.
7. Keep chain properly adjusted and sharpened.
8. It is unsafe for young children and persons unfamiliar with its usage to operate any chain saw.
9. When repairing or servicing, use only recommended Shindaiwa replacement parts.
10. Do not operate this or any chain saw without a muffler.
11. Keep the handles dry, clean and free of oil or fuel mixture.
12. All chain saw service, other than the items listed in the owner's manual maintenance instructions, should be performed by trained Shindaiwa chain saw service personnel. (For example, if improper tools are used to remove the fly-

wheel or if an improper tool is used to hold the flywheel in order to remove the clutch, structural damage to the flywheel could occur and could subsequently cause the flywheel to burst.)

WARNING! KICKBACK May Occur When The Nose Or Tip Of The Guide Bar Touches An Object, or When The Wood Closes In And Pinches The Saw Chain In The Cut. Tip Contact In some Cases May Cause A Lightning Fast Reverse REACTION, Kicking The Guide Bar Up And Back Towards The Operator.

Pinching The Saw Chain Along The Top of The Guide Bar May Push The Guide Bar Rapidly Back Towards The Operator.

Either Of These Reactions May Cause You To Lose Control of The Saw Which Could Result In Serious Personal Injury.

Do not rely exclusively upon the safety devices built into your saw. As a chain saw user, you should take several steps to keep your cutting jobs free from accident or injury.

13. Guard against kickback. Kickback is the upward motion of the guide bar that occurs when the saw chain at the nose of the guide bar contacts an object.

Kickback can lead to dangerous loss of control of the chain saw.

To reduce kickback:

- a) With a basic understanding of Kickback, you can reduce or eliminate the element of surprise. Sudden surprise contributes to accidents.
- b) Keep a good firm grip on the saw with both hands, the right hand on the rear handle, and the left hand on the front handle, when the engine is running.

SAW CHAIN SHARPENING

1. Designation -

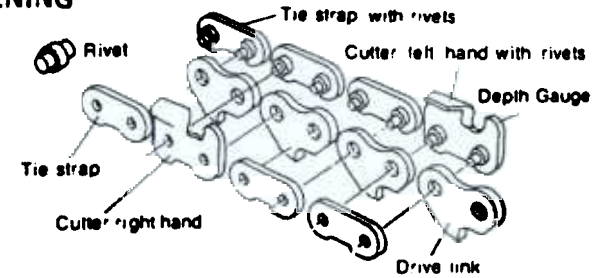

2. Function -

- a. The depth gauge controls depth or amount of cut for each tooth.
- b. Right and left cutters both should always be sharpened to uniform angle and depth.
- c. Drive links and saw chain together function to discharge sawdust.

3. Points of Sharpening -

- a. Sharpen all cutters and align right and left cutter angles to meet these specifications:

4. How to Sharpen -

- a. Sharpen right and left cutter angles uniformly to 30° with the round file. Unequal filing can cause erratic sawing and vibration. File in the direction as indicated with arrow.

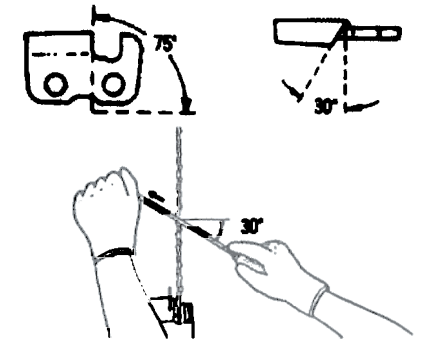

5. After Sharpening -

- a. When sharpening is completed, place the depth gauge joiner on all cutters as shown in the figure. File out (A) portion if it is higher than the joiner. Round the filed depth gauge as shown in the illustration.

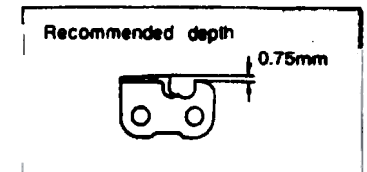
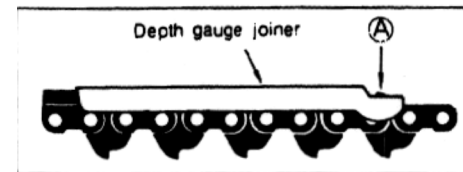

Carbon Removal from Muffler.

Disassemble muffler guard and cover muffler by releasing two nuts and a bolt.
Remove carbon buildup. Use caution to replace parts in proper order.

Spark Plug Inspection. Remove spark plug and clean it, then adjust the gap. Optimum clearance – 0.6 mm (.024"). Always use Champion CJ6Y

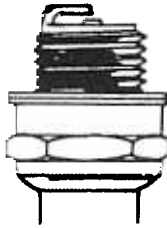

Sprocket Inspection.

Check rim (which drives chain behind clutch drum) after removing clutch cover.
If there is any wear on sprocket, replace with a new one.
Do not run saw without clutch cover properly installed.

Use a firm grip with thumbs and fingers encircling the chain saw handles.

A firm grip will help you reduce kickback and maintain control of the saw.

Don't let go.

- c) Only use replacement bars and chains specified by the manufacturer or the equivalent.
 - d) Hold the chain saw firmly with both hands.
 - e) Do not overreach.
 - f) Do not let the nose of the guide bar contact a log, branch ground, or any other obstruction.
 - g) Cut at high engine speeds.
 - h) Do not cut above shoulder height.
 - i) Follow manufacturer's sharpening and maintenance instructions for the saw chain.
 - j) Use devices, such as a low-kickback chain, chain brakes, and special guide bars, that reduce the hazards associated with kickback.
14. When transporting your chain saw, use the appropriate guide bar scabbard.
 15. Do not allow other persons to be near the chain saw when starting or cutting with the chain saw. Keep bystanders and animals out of the work area.
 16. Hold the chain saw firmly with both hands, the right hand on the rear handle and the left hand on the front handle, when the engine is running.
Use a firm grip with thumbs and fingers encircling the chain saw handles.
 17. Keep all parts of your body away from the saw chain when the engine is running.
 18. Do not operate a chain saw that is damaged, is improperly

adjusted, or is not completely and securely assembled. Do not run without clutch cover installed. Be sure that the saw chain stops moving when the throttle control trigger is released.

19. Shut off the engine before setting it down.
20. Use extreme caution when cutting small size brush and saplings because slender material may catch the saw chain and be whipped toward you or pull you off balance.
21. When cutting a limb that is under tension, be alert for springback so that you will not be struck when the tension in the wood fibers is released.
22. Operate the chain saw only in well-ventilated areas.
23. Do not operate a chain saw in a tree unless you have been specifically trained to do so.
24. Open fuel cap slowly to release any possible build-up of pressure. Do not refuel a hot saw. Allow to cool if possible.
25. Operation of a chainsaw with faulty or damaged anti-vibration mounts (isolators) can lead to higher vibration. Long-term vibration can cause damage to the operator's hands.
For lowest vibration, replace damaged mounts immediately. Mounts hardened due to age or weathering should also be replaced.
26. Prolonged exposure to excessive noise is fatiguing and could lead to impaired hearing.
The use of proper ear protection can reduce this potential hazard.

Note :

These safety precautions are intended primarily for the consumer or occasional user.

When using a chain saw for logging purposes, refer to

ROUTINE MAINTENANCE

1. Saw Chain –

Saw chain sharpness is essential in determining its performance. When cutter is in worn state, sharpen it at once. Cutting with a dull chain increases fatigue and greatly lowers cutting performance. When dirty from grease or pitch, wash with gasoline and immerse in oil to prevent rust.

2. Guide Bar –

Always clean the saw bar groove and oil hole. When they are clogged with chips, remove them.

For distribution of wear (and increased life), occasionally turn bar over.

3. Air Cleaner –

Remove air cleaner being careful not to drop dust in carburetor, and rinse with gasoline or solvent. When blowing with air, blow from inside filter.

After cleaning, it can be used at once.

4. Periodical Inspection and Maintenance –

Cylinder Fin Cleaning. Dirt or dust clogged fins can cause engine overheating. Clean between cylinder fins. When heavily clogged, cleaning should be made after removing recoil case.

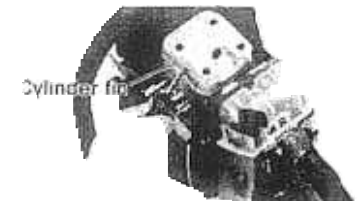

Fuel Filter. Take off filter by use of a wire hook through tank opening. Remove both filter elements and rinse them well with gasoline.



Oil Filter. Take out oil filter from oil tank in procedure as used for fuel filter. Then wash in gasoline after removal from hose.

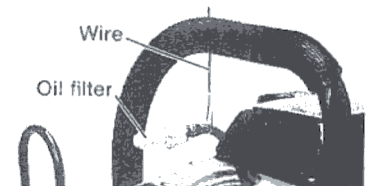

4. Bucking and Limbing –

a. For wood lying on the ground, use caution as to its stability. On a slope, always stand and work uphill to the log. Start cutting from the top of the log. Cut with repeating level action using saw spike as a fulcrum. Do not cut into dirt!

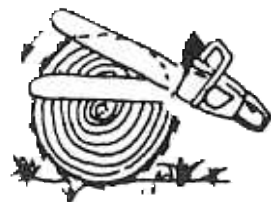

b. When cutting a log supported on both ends, begin from the top side by cutting down, 1/3 of the way through the log, and finish by coming up from the bottom. This prevents pitching of the guide bar.

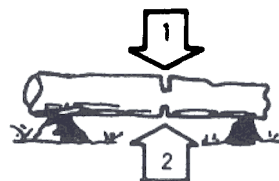

c. Limbing of standing tree. Cut 1/3 from the underside first, then cut through from the top. Thus easy limbing can be attained by cutting the remaining part flush with the trunk of the tree.

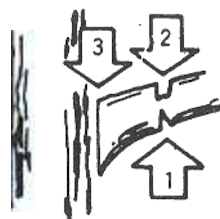

the Code of Federal Regulations, Section 1910. 266 (5); 2.5.1 of American National Standard Safety Requirements for Pulpwood Logging, ANSI 03.1—1978; and relevant state safety codes.

KICKBACK SAFETY FEATURES

This chain saw is equipped with the following safety equipment:

- Chain brake
- Low kick chain
- Guard-tip bar

The **chain brake** activates (causing a band to stop chain movement) when sufficient kickback energy is present for the operators' hand to contact the brake lever.

Proper adjustment is essential.

See page 16 for instructions.

CAUTION : Do not use a replacement saw chain unless it is designated or labeled as meeting Ansi B175.1 Kickback performance requirements for this model, or has been designated as "low-kickback chain" in accordance with the Ansi B175.1 standard.

Low Kick Chain— Significantly reduces the rotational force of kickback, if used conjunction with an approved bar, chain and saw combination.

Guard Tip Bar — A guide bar with a much smaller nose radius, to lower the overall kickback zone.

NOTE:

To reduce the risk of kickback, all of the above must be in good repair. Use of other than ANSI B175.1 combinations may produce much greater kickback energy.

Low-kickback saw chain is chain which has met the kickback performance requirements of ANSI- B175.1 (safety requirements for gasoline-powered chain saws) when tested on the representative sample of chan saws below 3.8 c.i.d specified in ANSI B175.1.

MOUNTING FULL WRAP HANDLE

Mount full wrap handle with 4 bolts and washers as picture shows.

Bolts and washers are attached to full wrap handle.

(Fastening torque : 80~90kg·cm)

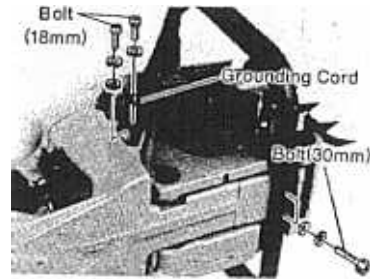

MOUNTING GUIDE BAR AND SAW CHAIN

1. Then install guide bar.

To install guide bar, insert the plate (A) and guide bar slot over bar studs.

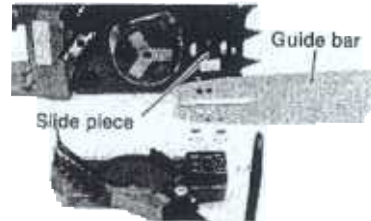

2. Fit saw chain first from sprocket rim side, then into guide bar groove toward bar tip.

Check if saw chain is properly fitted into rim.

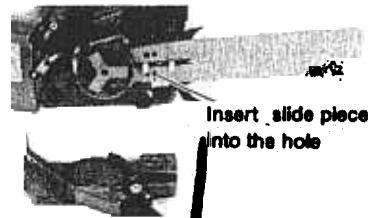

3. Secure clutch cover temporarily with 2 nuts.

Now saw chain adjustment operation begins.

After adjustment, fasten nuts properly.

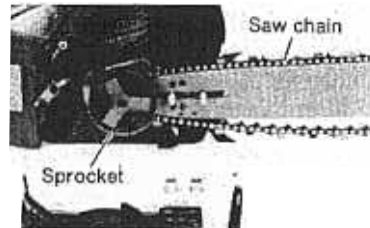

NOTE: Do not run saw without clutch cover.

CUTTING

1. Before Starting -

- Understand safety procedures.
- Clear a safe work area.
- One should wear safety helmet, protective wear for hands and feet, and close fitting but comfortable clothes.
- When moving from place to place, stop engine for safety.
- Always keep saw chain tensioned properly and inspect often.
- Check for loose bolts and nuts before use.

2. Efficient Operation -

Wood can be cut most efficiently by light pressure and with saw rpm in the 8,000 - 9,000 rpm range at full throttle.

NOTE:

High pressure against wood lowers engine rpm, increases fatigue, and lowers cutting performance, resulting in considerable efficiency loss.

3. Felling a Tree -

- Determine the direction of fall, considering size, shape and lean of tree.
- Clean around area for safe operation.
- Cut a notch about 1/3 of the diameter of the tree.
- The felling cut is horizontally made on the side opposite the notch and at a level about 5 cm (2") above the bottom notch. The remaining wood between notch cut and felling cut (about 3 to 5 cm - or 1" to 2") will act as a hinge and tree will fall in the direction of the notch. If pinching of the bar should occur during cutting, remove chain saw (with engine stopped) by the use of a wedge.

- When tree begins to fall, stop engine and give a signal to others in the area.

Remember: Falling direction is not always the one desired!

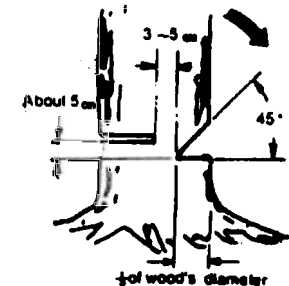

sure that brake band is not contacting clutch drum.)

NOTE:

Always stop engine during chain brake adjustment.

- c. After adjustment of chain brake, start engine and make brake actuating test and adjust as necessary.

To tighten chain brake, turn adjusting screw to the right.

3. Maintenance of Chain Brake –

- a. Always keep chain brake clean, free of sawdust and debris.
- b. Periodically check that brake band does not interfere with clutch drum when chain brake is not actuated. (If there is interference, adjust in accordance with number 2.)

CAUTION:

- 1. Never start and operate engine with chain brake actuated (chain stopped).
- 2. Always carry chain saw by its front handle (never carry by chain brake lever).
- 3. Be sure that brake lever is in vertical position (set state) during assembly and removal of chain brake.
- 4. The purpose of the chain brake is to minimize kickback danger, not to protect from careless usage.
- 5. Readjust carburetor if its adjustment was made while chain brake was actuated.

SAW CHAIN ADJUSTMENT

Correct saw chain tension is essential to achieve maximum performance for chain life, cutting ability, and safety. Whenever using a new chain, it is advisable to soak it in oil overnight before use and to check the chain tension from time to time because it can stretch after initial operation.

1. Proper Chain Tension:

To properly adjust tension, first lift bar nose to remove slack between bar mounting slot and bar studs. For hard nose bars, adjust until a slight pulling pressure on chain at mid-bar will leave 3 – 3.5 mm ($\pm 1/8$ ") gap between bar rail and chain side plate. (See photo)



For sprocket nose bars, adjust slightly tighter, still allowing chain to pull around bar freely.

CAUTION:

Loosely tensioned chain can cause unexpected accidents and lead to excessive bar and chain wear. Always check before use.

2. To Adjust:

- a) Loosen clutch cover nuts (2 pieces) about one turn.
- b) Turn slide screw with screw driver. Turn to right (clockwise) to tighten, and left (counter-clockwise) to loosen.



FILLING FUEL AND CHAIN OIL

1. Fuel Mixture:

Always use a gas/oil ratio of 25:1 or 40:1 with premium Shindaiwa brand oil.

2. Chain Oil:

This oil performs an essential role to reduce guide bar and chain wear, and to facilitate smooth cutting. Always use clean oil and refill when refueling.

NOTE:

During cold weather, it may be necessary to thin chain oil by mixing one part oil to one part kerosene to improve lubrication.

Running too heavy an oil can cause damage to oil pump drive gears.

3. Automatic Oiler:

The automatic oiler is designed to operate only when the chain is operating.

To adjust the automatic oiler, which leaves the factory at 2/3 open setting, turn to the left (counter-clockwise) to increase flow and to the right (clockwise) to decrease flow. A temporary increase in flow may be necessary in cutting hardwood or large diameter softwood.



CHAIN BRAKE

Model 575 is equipped with chain brake. If kickback should occur, chain brake will stop saw chain rotation when brake lever hits operator's hand.

1. Chain Brake Operation—

- a. Chain brake will release saw chain when in vertical position. (Position 1)
- b. Chain brake will actuate and lock saw chain when brake lever is in forward tilted position. (Position 2)
- c. When you want to release brake, pull brake lever back to vertical position (Position 1)

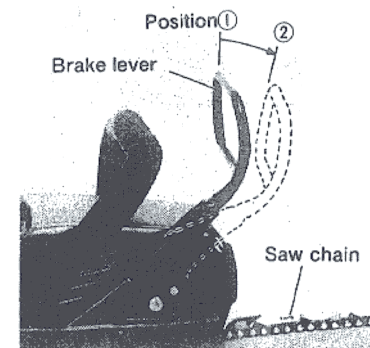

NOTE:

Upon actuating chain brake you should release throttle lever.

2. Chain Brake Adjustment —

Keep brake lever upright at position 1.

Adjust adjusting screw with straight blade screwdriver (-) as follows.

- a. Tighten adjusting screw so that saw chain will not rotate by hand when brake lever is raised in vertical position. (Position 1)
- b. Loosen and adjust adjusting screw about 2 to 4 times from this position so that saw chain is rotatable with lever in vertical position. (At this point make

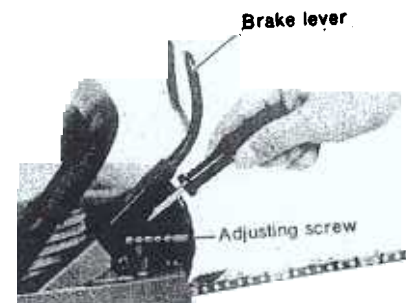

3. Adjustments for Low Speed (L) Adjusting Screw –

After adjusting according to number 2, continue to turn gently either to right or to left so that engine rotation may be speeded up. Continuing to turn will result in engine rpm decrease. Return to the position just before this slow-down and set at this point.

Next, as idle speed is considerably higher than in the case of number 1 setting, reset idle adjusting screw so that engine idles at 2,700 to 2,900rpm. By repeating this procedure two to three times, optimum low speed idle adjustment can be obtained.

4. High Speed (H) Adjustment –

No adjustment is necessary when the saw is new.

After approximately 10 hours running time, readjust the H - needle to 1-1/4 turns (\pm 1/4 turns).

CAUTION:

1. This saw contains an rpm-limiting ignition system. The yellow wire on the exciter coil controls this function. If cut, rpm increases excessively and damage can occur. (Warranty is void if yellow wire is cut !)
2. Do not run saw at full throttle with no load. If run in this condition, seizure can occur.
3. Do not adjust H - needle to less than 1 turn. If run at less than 1 turn, seizure can occur.

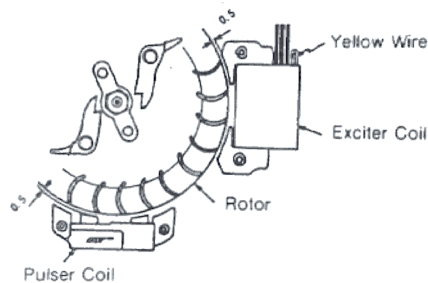

HEATED HANDLE (OPTIONAL : 575 G)

Turn switch to the "ON" position.
Front and rear handles will become warmer as the saw is run.

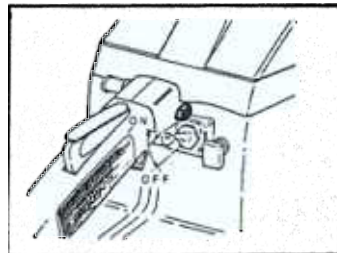

STARTING AND STOPPING

CAUTION:

Before starting, clear a safe work area. When the engine starts, the chain will rotate, so be prepared!

1. Starting:

- a. When engine is cool –
 - 1) Turn switch "ON";
 - 2) Pull choke lever all the way out.
 - 3) Depress lock lever ①, then push starting throttle lock ② into throttle lever.

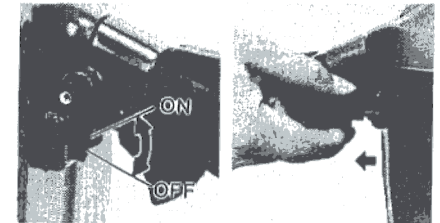

- b. When engine is warm –
 - 1) Set switch "ON"
 - 2) Depress lock lever, then push starting throttle lock into throttle lever.



NOTE :

Throttle lever cannot be pulled without depressing lock lever ① in upper handle. When throttle is released, idle speed is resumed, and chain rotation stops.

- 3) Pull recoil starter rope while holding the chain saw firmly and placing your right foot into rear handle as shown in the photo. Pull cord slowly until engaged, then rapidly after you can feel the increased resistance.



CAUTION:

Don't pull rope to its full length and do not let your hand slip off the rope when it is under tension.

Starting can be easily attained by pulling vigorously from the engaged position.

4) When engine fires or coughs , press choke in to the original off position and pull recoil starter again. Use caution as chain will rotate during engine starting. After brief removing of engine to clear carburetor, saw will idle with throttle lock off. If saw fails to start after a few pulls, follow above procedures from the beginning. If saw still will not start, flooding may have occurred so check as follows:

(a) Check spark by removing spark plug and shorting against cylinder while pulling recoil starter rope.

Make sure switch is "ON".

(b) Inspect to see if spark plug is fouled when removing plug.

If fouled: 1) Expel fuel by hand cranking several times without spark plug. 2) Wipe off excess fuel from plug and replace before starting engine.



NOTE:

1. Make sure switch is "ON" before starting.
2. Return choke to the original position when saw first fires after starting with full choke. (Otherwise flooding will result and engine won't start.)
3. Upon starting, allow to idle for 1 to 2 minutes for warm-up.

2. Stopping:

Turn switch "OFF" after idling at low speed for 1 to 2 minutes.

CAUTION :

1. Don't mix fuel or refuel saw around fire or flame.
2. Don't smoke while refueling or mixing fuel.
3. Always use a mixing ratio of 25 : 1 or 40 : 1 with premium Shindaiwa brand oil.
4. Don't use dirty or reclaimed oil.

CARBURETOR ADJUSTMENT

With engine running, adjust carburetor using the following procedures:

Idle Screw Adjustment –

Turn idle adjusting screw so that stable operation can be obtained at 2,700 to 2,900rpm.

Note: Turning adjusting screw clockwise increases rpm. (Saw chain will not turn at above rpm.)

Low Speed (L) and High Speed (H) Adjustment –

Standard opening:

- L 1·¼ ± ¼ turns
- H 1·¼ ± ¼ turns

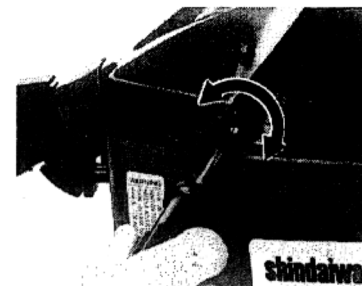

"Standard opening" means number of turns from the fully closed position by turning needle gently counter-clockwise.