

Chain Saw

MAC 1-10

P/N 63815, Serial No. 27001 & Up

MAC 2-10

P/N 63810, Serial No. 54001 & Up

ILLUSTRATED PARTS LIST

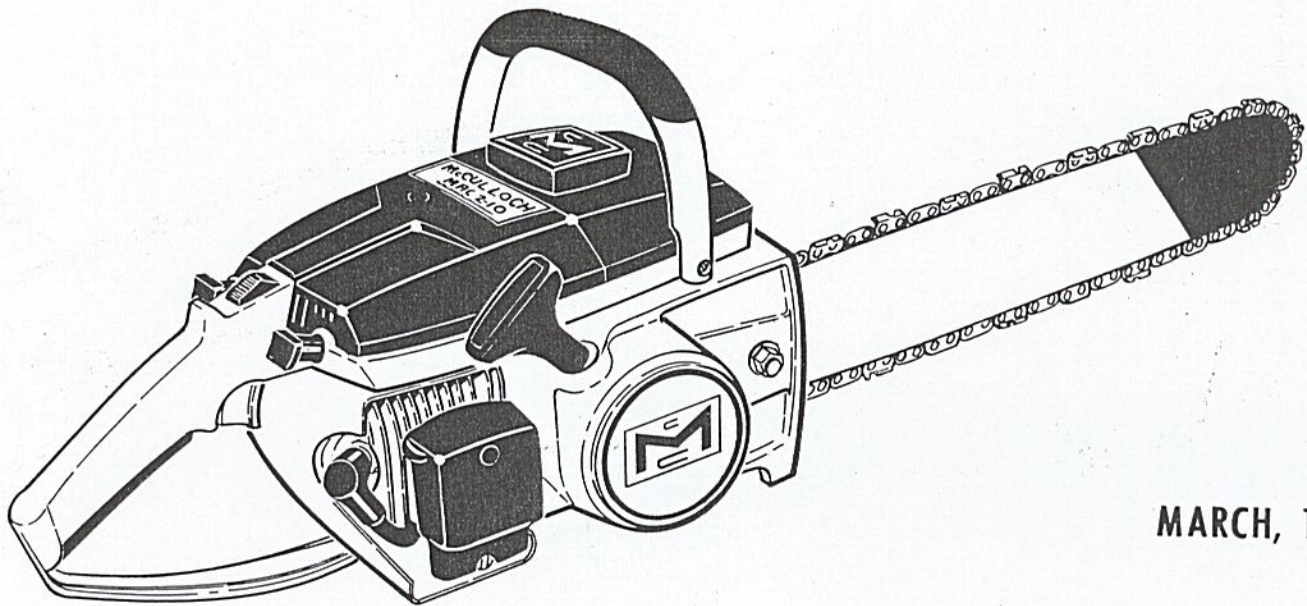

MARCH, 1966

The following pages contain an illustrated parts list for the MAC 1-10 and MAC 2-10 saws. Due to small differences between saws, it is important that the Serial Number of your saw be included whenever spare parts are ordered.

Part numbers which have changed since the previous printing of the illustrated parts list covering these saws, are indicated by a dash (-) preceding the new part number. The dash precedes part numbers changed by a letter suffix as well as those changed to an entirely new number.

	Page
Figure 1. Engine Exploded View - General	2
Figure 2. Clutch Guard and Starter Assembly	4
Figure 3. Fuel Tank Assembly	4
Figure 4. Carburetor Assembly	6
Figure 5. Powerhead Assembly	8
Figure 6. Bar and Chain Assembly	10

McCULLOCH CORPORATION

6101 West Century Boulevard, Los Angeles, California 90045

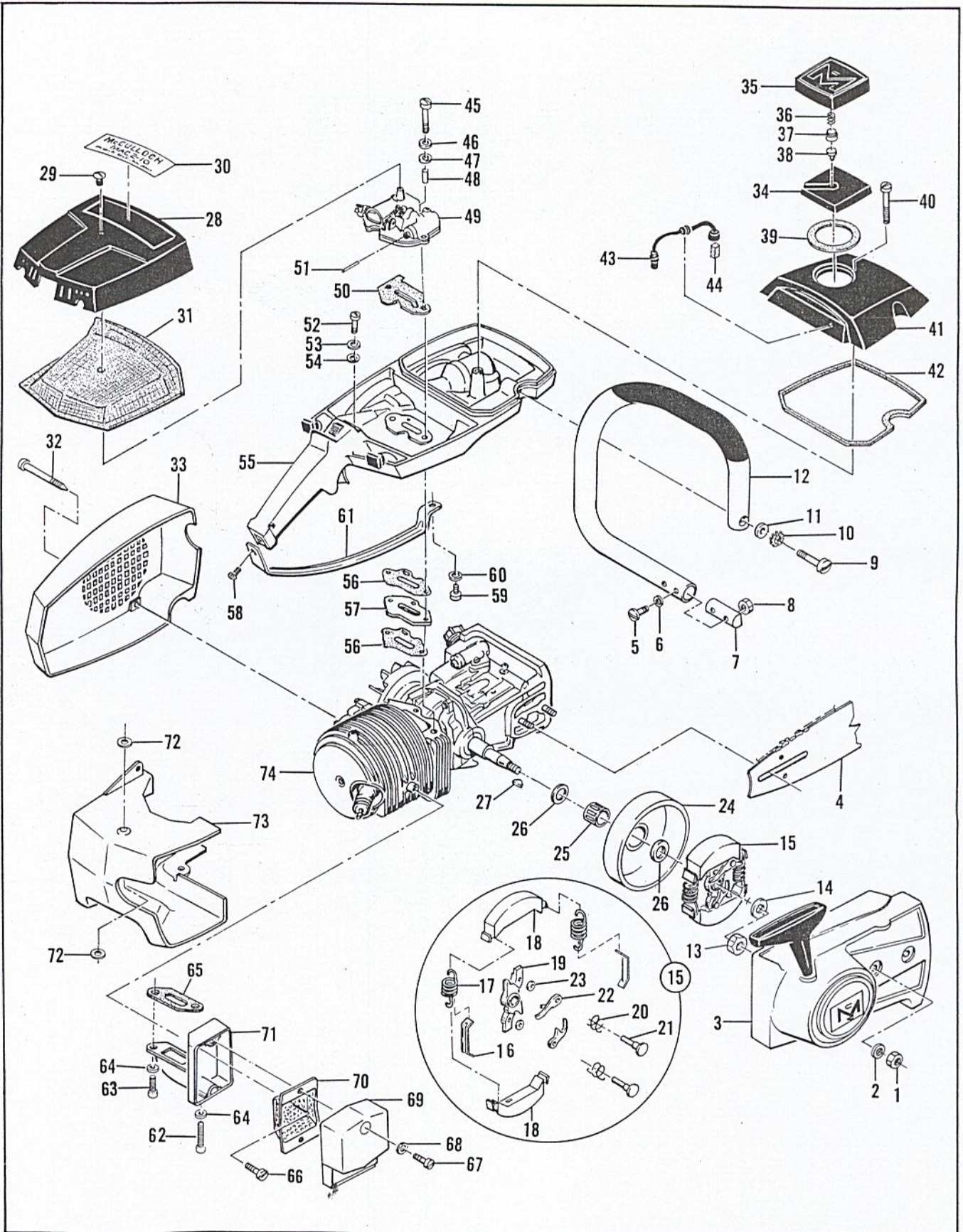

Figure 1. Engine Exploded View - General

FIGURE 1. ENGINE EXLODED VIEW — GENERAL

Index No.	Part Number	Nomenclature	Units Per Assy
1	101357	Nut - Hex 5/16-24	2
2	100440	Washer - 5/16 Plain	2
3		Clutch Guard and Starter Assy (See Figure 2)	1
4		Bar and Chain Assy (See Figure 6)	1
5	102761	Screw - Hex hd 10-24 x 7/8 in. lg	2
6	100352	Washer - #10	2
7	61678	Plug - Nut retainer	1
8	101326	Nut - Hex 10-24	2
9	103268	Screw - Fil hd 1/4-20 x 1-1/8 in. lg	1
10	105043	Lockwasher - 1/4 in.	1
11	100004	Washer - Plain 1/4 in.	1
12	63007	Frame and Grip Assy	1
13	110350	Nut - Hex 5/16-24	1
14	- 64751	Washer - Special	1
15	- 63930A	Clutch Assy	1
16	- 64583	. Retainer - Clutch spring	2
17	- 63999	. Spring - Clutch	2
18	62198B	. Shoe - Clutch	2
19	63931	. Rotor Assy - Clutch	1
20	62328	. . Spring - Pawl	2
21	62202B	. . Rivet - Pawl	2
22	62199A	. . Pawl - Starter	2
23	62314	. . Washer - Special	2
	62572B	Kit - Sprocket, Drum and Bearing Assy	1
24	- 62562B	. Sprocket and Drum Assy (7-tooth spkt)	1
25	110330	. Bearing - Sprocket drum	1
26	61692	. Shim - Sprocket	2
27	103879	Key - Woodruff	1
28	62117	Cover Assy - Air cleaner	1
29	62434	. Nut - Air cleaner cover	1
30	63029	Nameplate - MAC 2-10	1
	63028	Nameplate - MAC 1-10	1
31	62077	Screen - Air cleaner	1
32	62978	Screw - Special	3
33	63073	Fan Housing	1
34	61721C	Cap Assy - Fuel	1
35	61720	. Cover - Fuel cap	1
36	63040	. Spring	1
37	62316	. Guide - Spring	1
38	63041	. Valve	1
39	61722C	. Gasket	1
40	110334	Screw - Oval hd 12-24 x 1-3/4 in. lg	1
41	63069	Cover - Fuel tank	1
42	62102	Gasket - Fuel tank cover	1
43	- 61724A	Hose Assy - Fuel	1
44	61723	. Filter - Fuel	1
45	102433	Screw - Hex hd 10-24 x 1-5/8 in. lg	2
46	100352	Washer - #10 Plain	2
47	55636	Washer - Insulator	2
48	62327	Sleeve - Insulator	2
49	62300C	Carburetor Assy (See Figure 4)	1
50	62080B	Gasket - Carburetor	1
51	62066	Rod - Primer	1
52	102760	Screw - Hex hd 10-24 x 1 in. lg	1
53	100352	Washer - #10 Plain	1
54	55636	Washer - Insulator	1
55	63068	Fuel Tank Assy (See Figure 3)	1
56	62995	Gasket - Fuel tank	2
57	- 63396	Insulator - Fuel tank	1
58	110353	Screw - Oval hd 10-24 x 3/8 in. lg	1
59	102289	Screw - Hex hd 10-24 x 3/4 in. lg	1
60	100352	Washer - #10 Plain	1

This list is continued on page 5

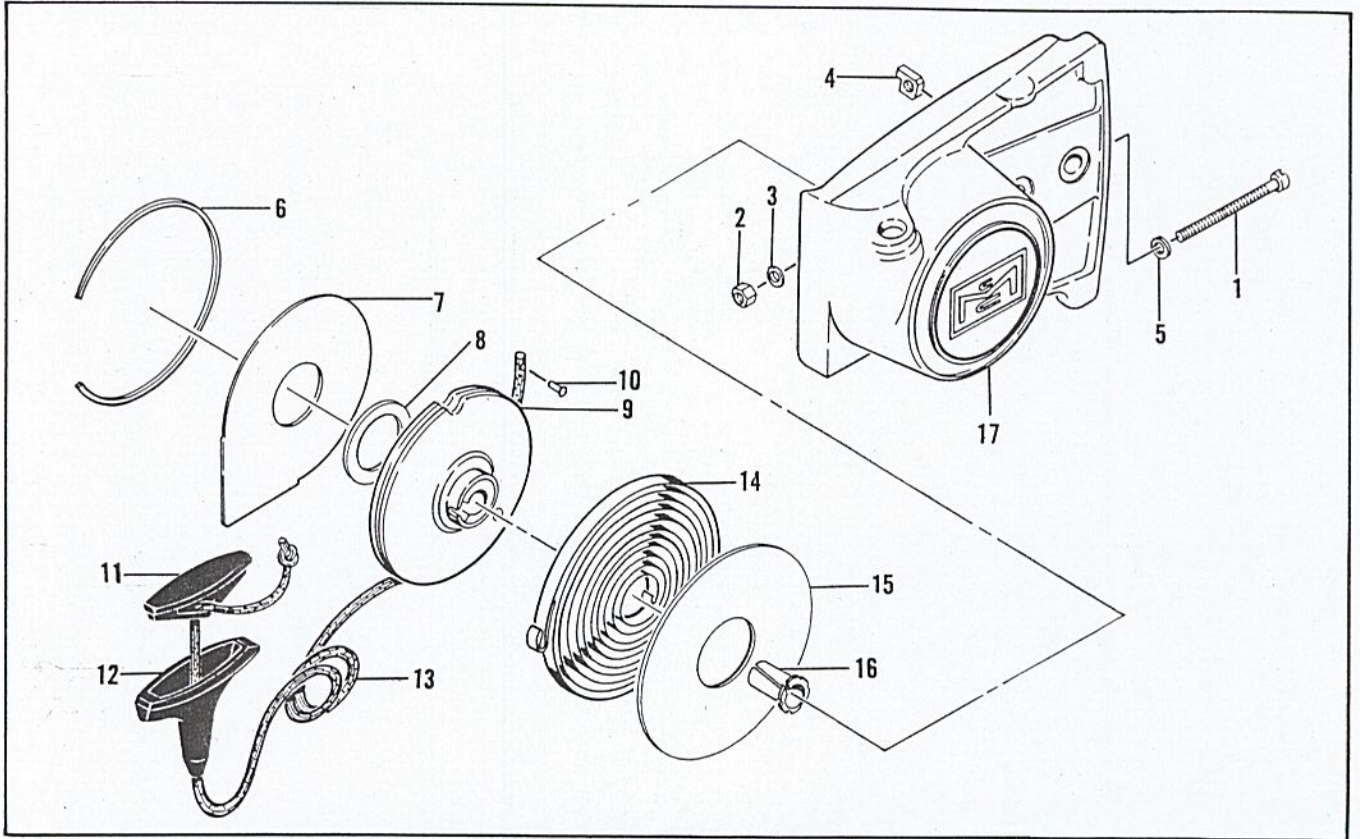

Figure 2. Clutch Guard and Starter Assembly

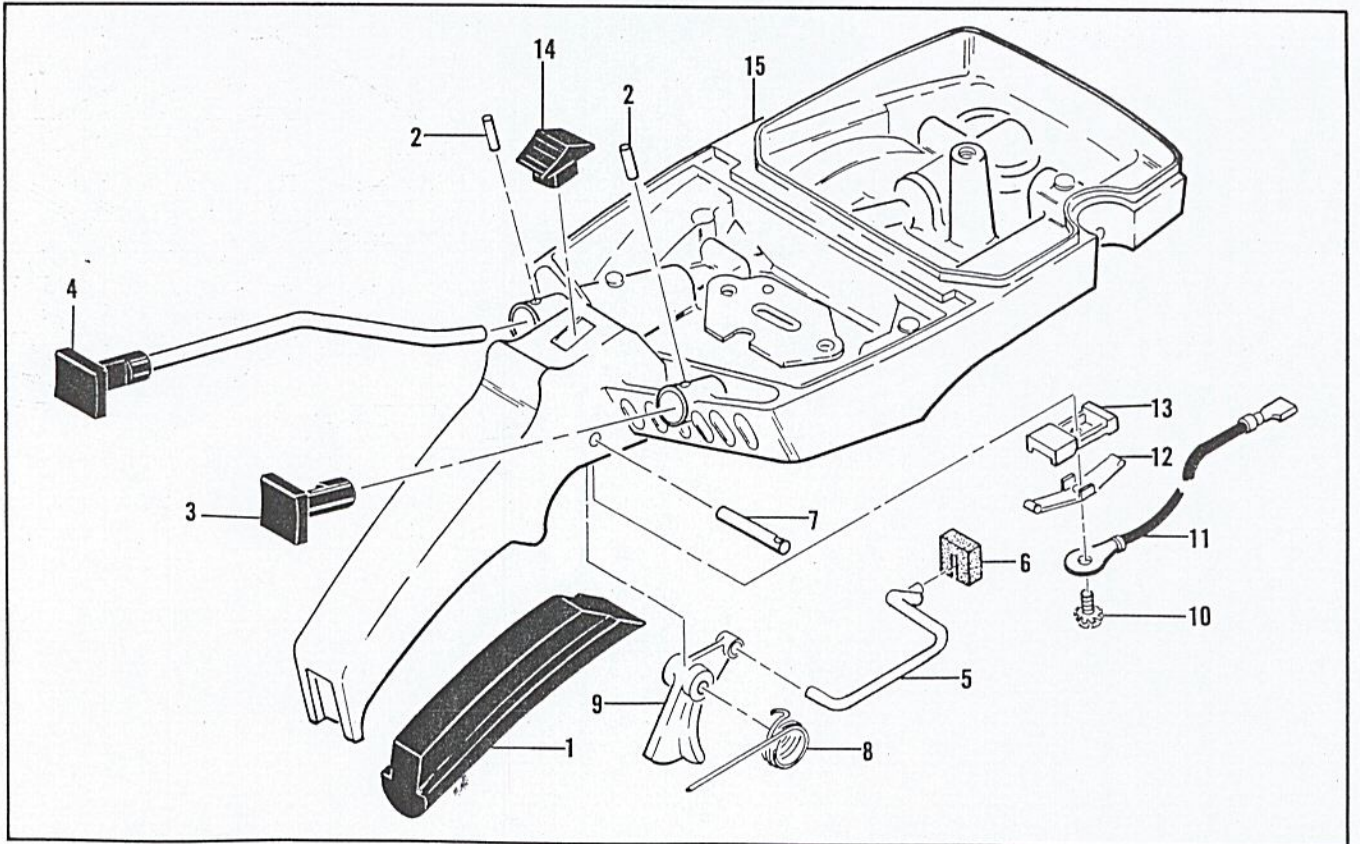

Figure 3. Fuel Tank Assembly

FIGURE 1. ENGINE EXLODED VIEW — GENERAL (CONTINUED)

Index No.	Part Number	Nomenclature	Units Per Assy
61	63070	Brace - Handle	1
62 -	104534	Screw - Skt 10-24 x 1-3/8 in. lg.	1
63 -	104895	Screw - Skt 10-24 x 5/8 in. lg.	1
64	110264	Washer - Plain #10	2
65	62337	Gasket - Spark arrester	1
66	110341	Screw - Hex hd 10-24 x 1/2 in. lg.	1
	62366B	Spark Arrester Assy	1
67 -	101284	. Screw - Fil hd 10-24 x 1-1/8 in. lg.	2
68	110264	. Washer - Special	4
69	62380	. Cover Assy - Spark arrester	1
70	62379A	. Baffle - Spark arrester	1
71	63364	. Body and Duct Assy - Spark arrester	1
72	62085A	Insulator - Shroud	2
73	63074	Shroud - Cylinder	1
74		Powerhead Assy (See Figure 5)	1

FIGURE 2. CLUTCH GUARD AND STARTER ASSEMBLY

Index No.	Part Number	Nomenclature	Units Per Assy
-	63075B	Clutch Guard Assy	1
1	102144	. Screw - Bar adjusting	1
2	102067	. Nut - Hex #10 lock	1
3	110387	. Washer - Wave	1
4	61705	. Nut - Bar adjusting	1
5	101174	. Washer - #10	1
6	62371	. Retainer - Shield	1
7 -	63985	. Shield - Dust	1
8	63986	. Washer - Thrust	1
9 -	62179A	. Drum - Starter	1
10	101136	. Rivet - Starter rope	1
11	62191	. Insert - Starter rope	1
12 -	62190A	. Handle - Starter	1
13	59952A	. Rope - Starter	1
14	36059	. Spring - Starter rewind	1
15	63987	. Shield - Starter spring	1
16	61635A	. Bushing - Nyliner	1
17 -	63071B	. Guard - Clutch	1

FIGURE 3. FUEL TANK ASSEMBLY

Index No.	Part Number	Nomenclature	Units Per Assy
-	63826	Tank Assy - Fuel	1
1	62076	. Grip - Handle	1
2	105673	. Roll Pin - 3/32 x 9/16 in.	2
3	63045	. Button - Primer	1
4	63052	. Button and Rod Assy - Oiler	1
5	62970B	. Rod - Throttle	1
6	61696	. Seal - Throttle rod	1
7	110378	. Roll Pin - 3/16 x 15/16 in.	1
8	59598	. Spring - Throttle return	1
9	62949	. Trigger - Throttle	1

This list is continued on page 7

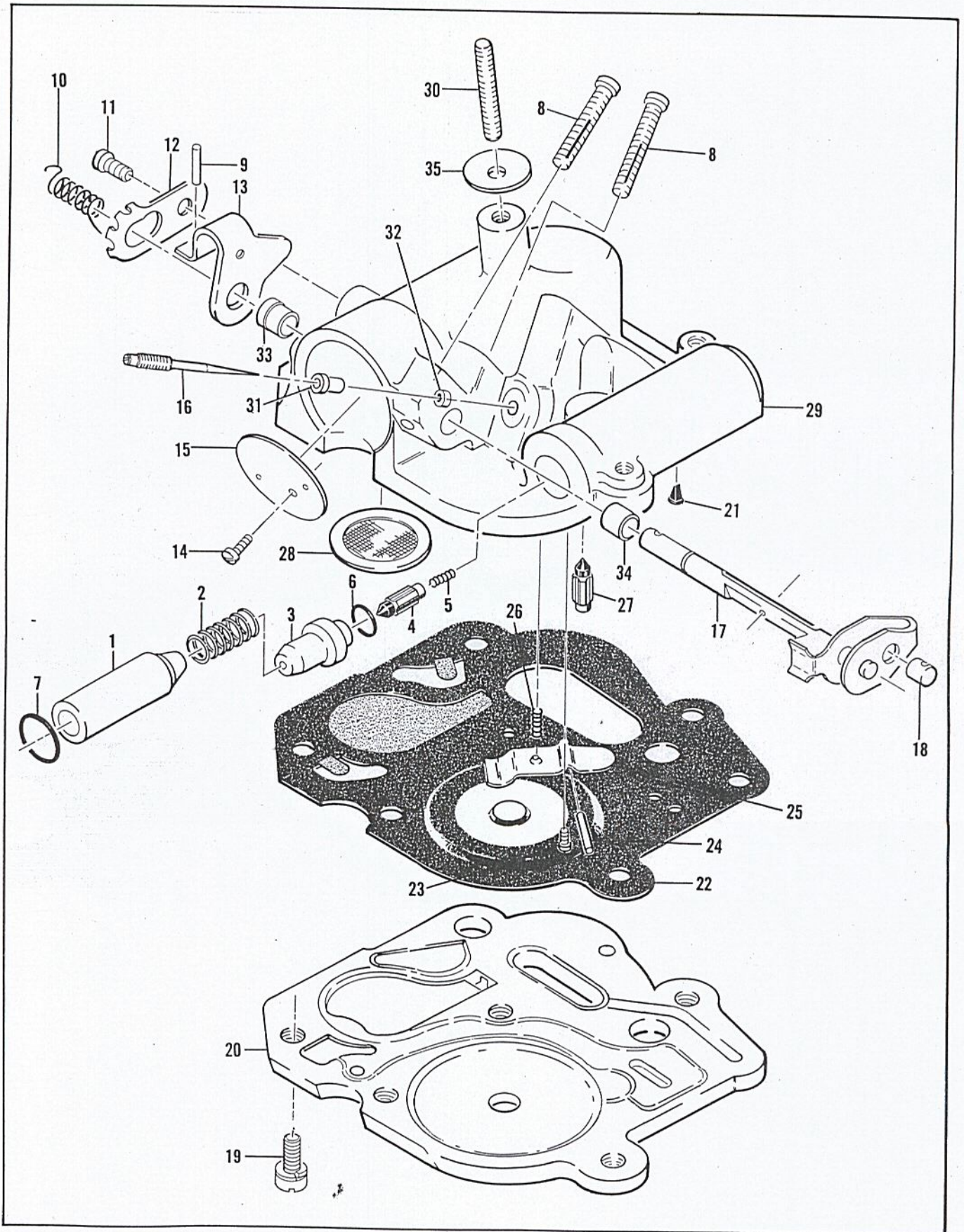

Figure 4. Carburetor Assembly

FIGURE 3. FUEL TANK ASSEMBLY (CONTINUED)

Index No.	Part Number	Nomenclature	Units Per Assy
10	103672	. Screw - Fil hd 8-32 x 1/2 in. lg. (SEMS)	1
11	62973A	. Wire Assy - Stop switch	1
12	62451	. Contact - Ignition switch	1
13	62950A	. Base - Ignition switch	1
14	62951	. Button - Ignition switch	1
15		. Tank - Fuel (Order Fuel Tank Assy #63826)	1

FIGURE 4. CARBURETOR ASSEMBLY

Index No.	Part Number	Nomenclature	Units Per Assy
-	62300D	Carburetor Assy	1
1	62308A	. Plunger - Primer	1
2	11086	. Spring - Plunger	1
3	63037	. Seat - Primer valve	1
4	63038	. Valve - Primer needle	1
5	63039	. Spring - Needle valve	1
6	101056	. "O" Ring	1
7	110351	. "O" Ring	1
8	62971	. Screw - Long locking adjustment	2
9	104443	. Roll Pin - .062 x 3/8 in.	1
10	62939A	. Spring - Idle governor	1
11	101207	. Screw - Rd hd 6-32 x 1/4 in. lg.	1
12	62938	. Clip - Throttle shaft	1
13	62343A	. Lever - Throttle	1
14	104814	. Screw - Pan hd 4-40 x 1/4 in. lg. (SEMS)	1
15	62290A	. Plate - Throttle	1
16	62976A	. Needle - Metering	1
17	62291A	. Shaft Assy - Throttle	1
18	62975	. Swivel - Needle	1
19	110397	. Screw - Pan hd 8-32 x 7/16 in. lg. (SEMS)	5
20	63042	. Plate - Carburetor base	1
21	63041	. Valve - Primer	1
22	63013	. Diaphragm Assy - Pump	1
23	104728	. Screw - 6-32 x 1/4 in. lg.	1
24	110337	. Pin - Inlet lever	1
25	62310	. Lever - Inlet	1
26	62923A	. Spring - Inlet lever	1
27	63038	. Valve - Inlet needle	1
28	55690B	. Seal - Capillary	1
29	63019B	. Body Assy - Carburetor	1
30	62433A	. Stud - Carburetor	1
31	62295D	. Orifice - Air	1
32	63813	. Orifice - Fuel	1
33	62288A	. Bushing - Throttle shaft	1
34	62368	. Bushing - Throttle shaft	1
35	62435	Seal - Air cleaner stud	1

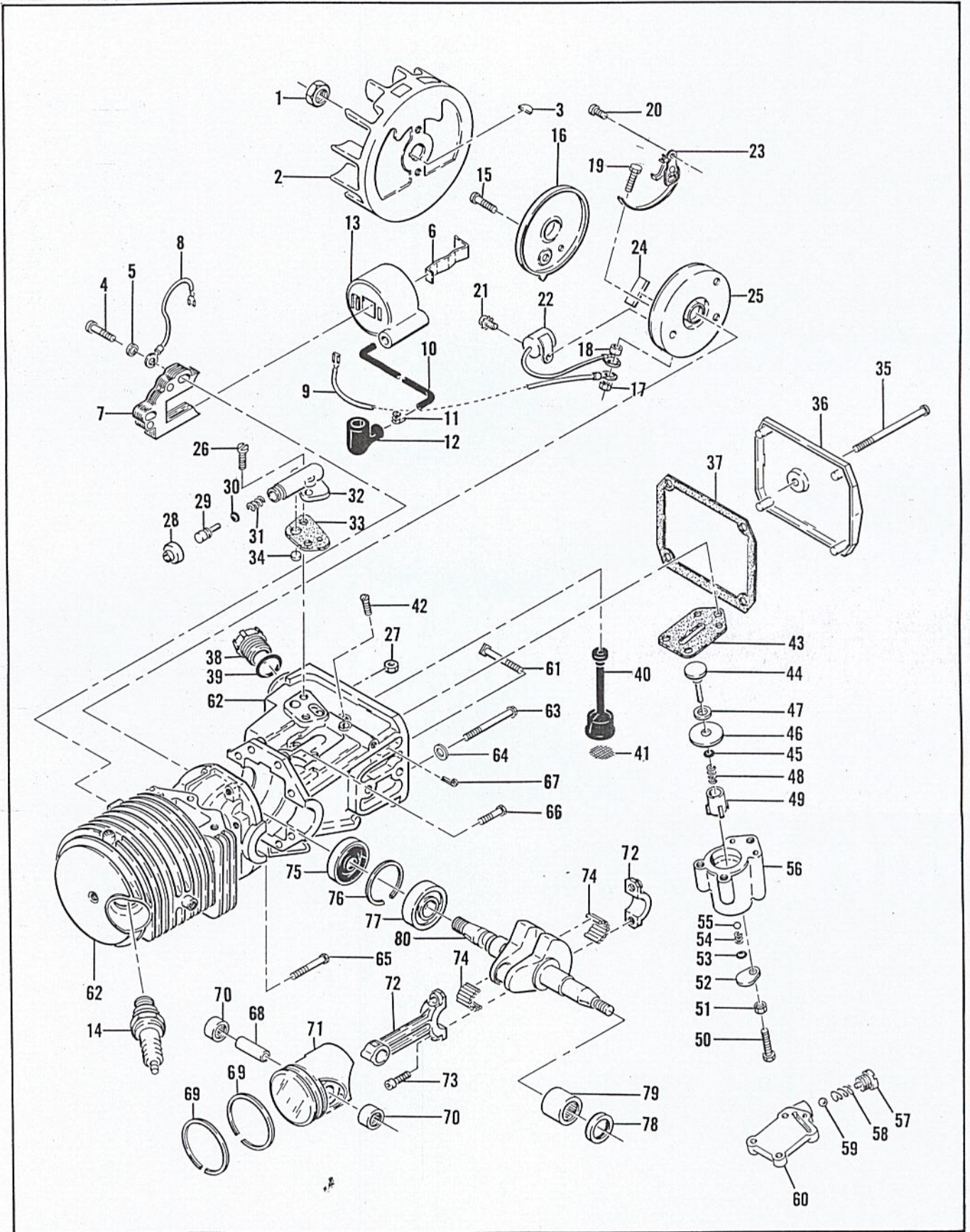

Figure 5. Powerhead Assembly

FIGURE 5. POWERHEAD ASSEMBLY

Index No.	Part Number	Nomenclature	Units Per Assy
1	101391	Nut - Hex 3/8-24	1
2	61737	Flywheel Assy	1
3	103879	Key - Flywheel	1
4	101965	Screw - Fil hd 10-24 x 7/8 in. lg. (SEMS)	2
5	100002	Washer - #10 Plain	2
6	51253	Retainer - Coil	1
7	62741	Lamination Assy	1
8	62819	Wire Assy - Ground	1
9	62818	Wire Assy - Primary	1
-	62927A	Coil and Terminal Assy	1
10	62929A	. Wire Assy - Spark plug	1
11	62932	. . Connector	1
12	62926	. . Boot	1
13		. Coil Assy (Order Coil & Terminal Assy #62927)	1
14	63097	Spark plug (Packaged)	1
15	110349	Screw - Rd hd 8-32 x 3/4 in. lg.	1
16	62362	Cover - Breaker box	1
17	100298	Nut - Hex 6-32	1
18	62365	Spacer - Breaker screw	1
19	110346	Screw - Hex hd 6-32 x 3/4 in. lg.	1
20	100934	Screw - Rd hd 8-32 x 3/8 in. lg.	2
21	105249	Screw - Rd hd 8-32 x 3/8 in. lg. (SEMS)	1
22	61650	Condenser	1
23	62363	Breaker Assy	1
24	54184	Wiper - Cam	1
25	62361	Box - Breaker	1
26	- 100934	Screw - 8-32 x 1/2 in. lg.	2
27	100955	Nut - Hex 8-32	1
	62319A	Pump Assy - Oil	1
28	62262	. Cap - Oil pump	1
29	62266	. Plunger - Oil pump	1
30	101056	. "O" Ring	1
31	59934	. Spring - Oil pump	1
32		. Housing - Oil pump (Order Pump Assy #62319A)	1
33	62230	Gasket - Oil pump	1
34	62909	Valve - Oil pump	1
35	110291	Screw - Pan hd 10-24 x 2-3/4 in. lg.	1
36	63072	Cover - Oil tank	1
37	62116	Gasket - Oil tank cover	1
38	57129A	Cap - Oil	1
39	101148	"O" Ring	1
40	- 62123B	Hose Assy - Oil	1
41	51506	. Screen - Oil hose	1
42	110333	Screw - Oval hd 8-32 x 1/2 in. lg.	3
43	62274	Gasket - Pulse pump	1
	*62320A	Pulse Pump Assy	1
44	*60260A	. Piston Assy - Pulse oiler	1
45	*101758	. "O" Ring	1
46	*62063	. Ring - Piston oiler	1
47	*60937	. Washer - Teflon	1
48	*60259	. Spring - Piston oiler	1
49	*62227	. Sleeve - Oiler adjustment	1
50	*110386	. Screw - Hex hd 8-32 x 1 in. lg.	1
51	*100251	. Nut - Hex 8-32	1
52	*62407	. Cover - Outlet valve	1
53	*103195	. "O" Ring	1
54	*62885A	. Spring - Outlet valve	1
55	*102809	. Ball - 3/32 in. dia	1
56	*62321A	. Body Assy - Pulse pump	1

*Used on MAC 2-10 engines only

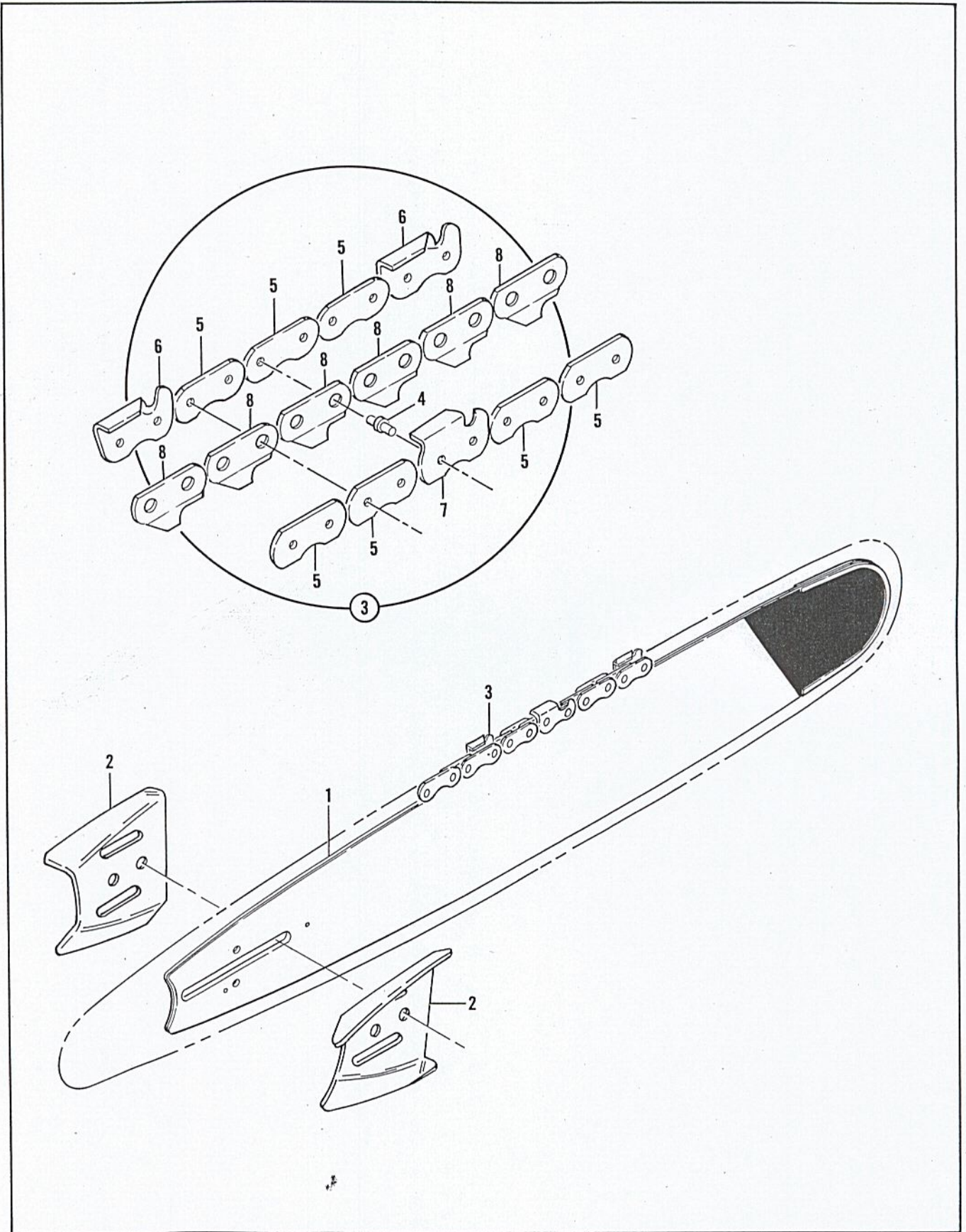

Figure 6. Bar and Chain Assembly

FIGURE 5. POWERHEAD ASSEMBLY (CONTINUED)

Index No.	Part Number	Nomenclature	Units Per Assy
	**63263	Body Assy - Manual oiler	1
57	**63262	. Screw - Check valve	1
58	**63034	. Spring - Check valve	1
59	**100071	. Ball - Check valve	1
60	**	. Body - Check valve (Order Body Assy #63263)	1
61	62065	Bolt - Bar mounting	2
62	62924A	Cylinder - Crankcase Assy	1
63	62105	. Screw Assy - Sealing	4
64	62842	. Washer - Sealing	4
65	110289	. Screw Assy - 8-32 x 1-1/8 in. lg.	1
66	110288	. Screw Assy - 8-32 x 3/4 in. lg.	3
67	101495	. Cotter Pin - 3/32 x 1/2 in. lg.	1
68	61649	Pin - Piston	1
	62824	Piston Assy.	1
69	62814	. Ring Set - Piston	1
70	103512	. Bearing - Needle	2
71		. Piston (Order Piston Assy #62824)	1
72	62830	Connecting Rod Assy.	1
73	61627	. Screw - Socket hd 8-36 x 1/2 in. lg.	2
74	63225	. Roller - Needle (Set of 20)	1
75	61618	Oil Seal	1
76	110276	Retainer - Bearing	1
77	110348	Bearing - Ball	1
78	110260	Oil Seal	1
79	104357	Bearing - Needle	1
80	61616	Crankshaft	1

**Used on MAC 1-10 engines only

FIGURE 6. BAR AND CHAIN ASSEMBLIES

Index No.	Part Number	Nomenclature
1	62685	Series 10 Bonded Bar 24 in. (Includes Set of Bar Protector Plates #62672)
	62682	Series 10 Bonded Bar 20 in. (Includes Set of Bar Protector Plates #62672)
	62512	Series 10 Bonded Bar 16 in.
	62532	Series 10 Bonded Bar 12 in.
	63547	Series 10 Solid Bar 28 in. (Includes Set of Bar Protector Plates #62672)
	63543	Series 10 Solid Bar 24 in. (Includes Set of Bar Protector Plates #62672)
	63542	Series 10 Solid Bar 20 in. (Includes Set of Bar Protector Plates #62672)
	63541	Series 10 Solid Bar 16 in.
2	62672	Bar Protector Plate (Set of 2) (Accessory Item)
3	64078	Chain Assy - Continuous (28 in. Bar)
	64076	Chain Assy - Continuous (24 in. Bar)
	62645	Chain Assy - Continuous (20 in. Bar)
	62556	Chain Assy - Continuous (16 in. Bar)
	62555	Chain Assy - Continuous (12 in. Bar)
4		. Rivet
5		. Side Link
6		. Cutter L.H.
7		. Cutter R.H.
8		. Center Link



TOOLS AND ACCESSORIES

Part Number	Nomenclature
63970	Owner's Manual
62827	Wrench - Screwdriver combination
63341A	Kit - Spike, 4-tooth
62825	Piston Assy - 0.020 in. oversize
62813	. Ring Set - Piston 0.020 in. oversize
103512	. Bearing - Needle (2)
62826	Piston Assy - 0.030 in. oversize
62812	. Ring Set - Piston 0.030 in. oversize
103512	. Bearing - Needle (2)

The policy of McCulloch Corporation is one of continual improvement in design, manufacturing and engineering advancement wherever possible to assure still finer two-cycle power tools. Hence, specifications, equipment, colors, design and manufacturer's suggested list prices are subject to change without notice and McCulloch Corporation reserves the right to make such changes without prior notification or obligation to backfit or supply backfit components for units previously shipped from the factory.