

# MASTER ILLUSTRATED PARTS LIST

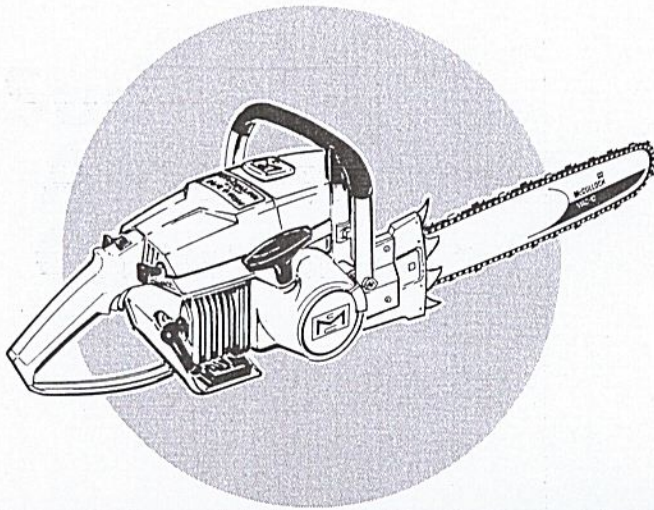

## Super LG-2 Automatic Chain Saw

January 1970

### · CONTENTS ·

The policy of McCulloch Corporation is one of continual improvement in design, manufacturing and engineering advancement wherever possible to assure still finer two-cycle power tools. Hence, specifications, equipment, colors, design and manufacturer's suggested list prices are subject to change without notice and McCulloch Corporation reserves the right to make such changes without prior notification or obligation to backfit or supply backfit components for units previously shipped from the factory.

	Page
Figure 1. General . . . . .	2
Figure 2. Clutch and Starter Assembly . . .	4
Figure 3. Fuel Tank Assembly . . . . .	6
Figure 4. Carburetor Assembly . . . . .	8
Figure 5. Carburetor Assembly . . . . .	8
Figure 6. Transmission Assembly . . . . .	10
Figure 7. Powerhead Assembly . . . . .	12

This Master Illustrated Parts List gives the name, number and interchangeability between engines, of service and replacement parts which were used on or are presently available for all Super LG-2 chain saws manufactured to date.

Information about the List and how to use it will be found on the back cover.  
Read the information before you start to use the List.

 **McCULLOCH**

# SUPER LG-2 Automatic

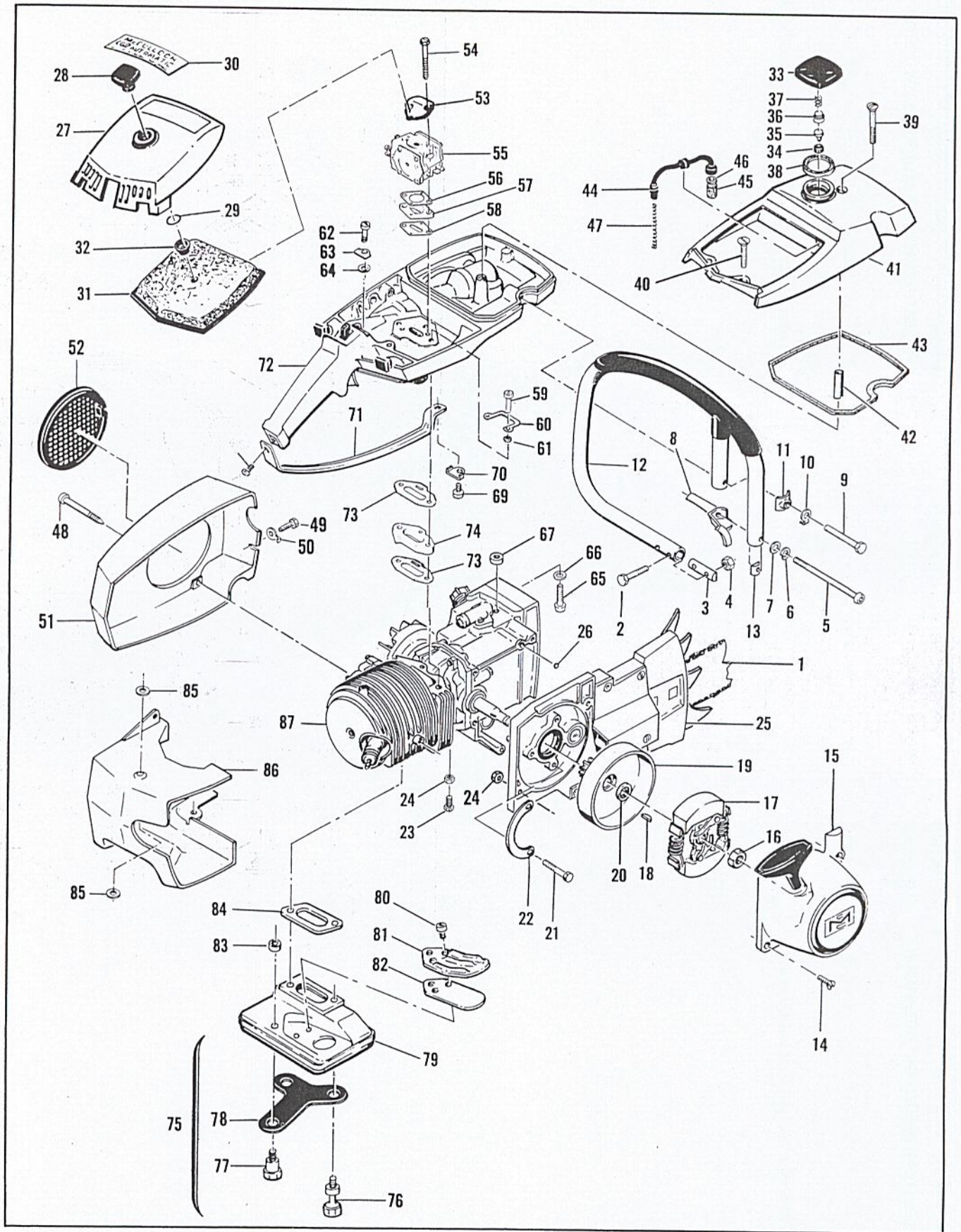

Figure 1. General.

**Figure 1. General**

Item No.	Part Number	Description	Units Per Assy	Usable on Code								
Super LG-2 - Usable On Code												
		<table border="1" style="width: 100%; border-collapse: collapse;"> <thead> <tr> <th style="width: 25%;">Letter</th> <th style="width: 25%;">A</th> <th style="width: 25%;">B</th> <th style="width: 25%;">C</th> </tr> </thead> <tbody> <tr> <td>Serial Numbers</td> <td>Prefix 11- All</td> <td>Prefix 12- 10001 - 10451</td> <td>Prefix 12- 10451 and Up</td> </tr> </tbody> </table>	Letter	A	B	C	Serial Numbers	Prefix 11- All	Prefix 12- 10001 - 10451	Prefix 12- 10451 and Up		
Letter	A	B	C									
Serial Numbers	Prefix 11- All	Prefix 12- 10001 - 10451	Prefix 12- 10451 and Up									
1		Bar & Chain Assy . . . . .	1	All								
2	102761	Screw - Hex hd 10-24 x 7/8 . . . . .	2	All								
3	61678	Plug - Nut retainer . . . . .	1	All								
4	101326	Nut - Hex 10-24 . . . . .	2	All								
5	110448	Screw - Skt hd 10-24 x 3-1/4 . . . . .	1	All								
6	103174	Lockwasher - #10 . . . . .	1	All								
7	100003	Washer - #10 . . . . .	1	All								
8	68503	Bracket - Frame . . . . .	1	All								
9	102130	Screw - Hex hd 1/4-20 x 1-1/2 . . . . .	1	All								
10	69947	Lockplate . . . . .	1	All								
11	63484	Clamp - Frame . . . . .	1	All								
12	68458	Frame & Grip Assy . . . . .	1	All								
13	62271	Plug - Frame . . . . .	1	All								
14	110622	Screw - Oval hd 10-24 x 7/8 . . . . .	1	All								
15		Starter Assy ( See Figure 2) . . . . .		All								
16	110594	Nut - 3/8-24 . . . . .	1	All								
17		Clutch Assy - (See Figure 2) . . . . .		All								
18	103879	Key - Woodruff . . . . .	1	All								
19	63493	Drum, Gear & Seal Assy . . . . .	1	All								
20	63476	Seal . . . . .	1	All								
21	104243	Screw - Hex hd 1/4-20 x 1-3/4 . . . . .	2	All								
22	68509	Lockplate . . . . .	1	All								
23	103469	Screw - Hex hd 10-24 x 3/8 . . . . .	1	All								
24	105367	Nut - Hex 10-24 . . . . .	2	All								
25		Transmission Assy (See Figure 6) . . . . .		All								
26	106104	"O" Ring . . . . .	1	All								
27	68530	Cover Assy - Air cleaner . . . . .	1	All								
28	68529	Knob . . . . .	1	All								
29	110565	Ring - Retaining . . . . .	1	All								
30	83365	Nameplate . . . . .	1	All								
31	83230	Filter Assy - Air . . . . .	1	All								
32	68528	Grommet . . . . .	1	All								
33	68531	Fuel Cap Assy . . . . .	1	All								
34	68533	Plug . . . . .	1	All								
35	63041	Valve . . . . .	1	All								
36	62316	Guide . . . . .	1	All								
37	63040	Spring . . . . .	1	All								
38	69767	Gasket . . . . .	1	All								
39	110402	Screw - Oval hd 12-24 x 2-3/8 . . . . .	1	All								
40	103579	Screw - Fl hd 10-24 x 1 . . . . .	2	All								
41	69679	Cover - Fuel tank . . . . .	1	All								
42	69686	Spacer - Cover . . . . .	1	All								
43	69345	Gasket - Fuel tank . . . . .	1	All								
44	64848	Hose Assy - Fuel . . . . .	1	All								
45	63932	Filter - Fuel . . . . .	1	All								
46	100440	Washer . . . . .	1	All								
47	67944	Spring - Hose . . . . .	1	All								
48	62978	Screw - Special . . . . .	3	All								
49	102762	Screw - 10-24 x 1/2 . . . . .	1	All								
50	69890	Lockplate . . . . .	1	All								
51	83521	Kit - Fan housing . . . . .	1	All								
52	55615	Guard - Flywheel . . . . .	1	All								
53	83204	Bracket Kit . . . . .	1	All								
54	103357	Screw - Hex hd 10-24 x 2-1/4 . . . . .	2	All								
55		Carburetor Assy (See Figures 4 and 5) . . . . .		All								

(This list continued on page 4)

# SUPER LG-2 Automatic

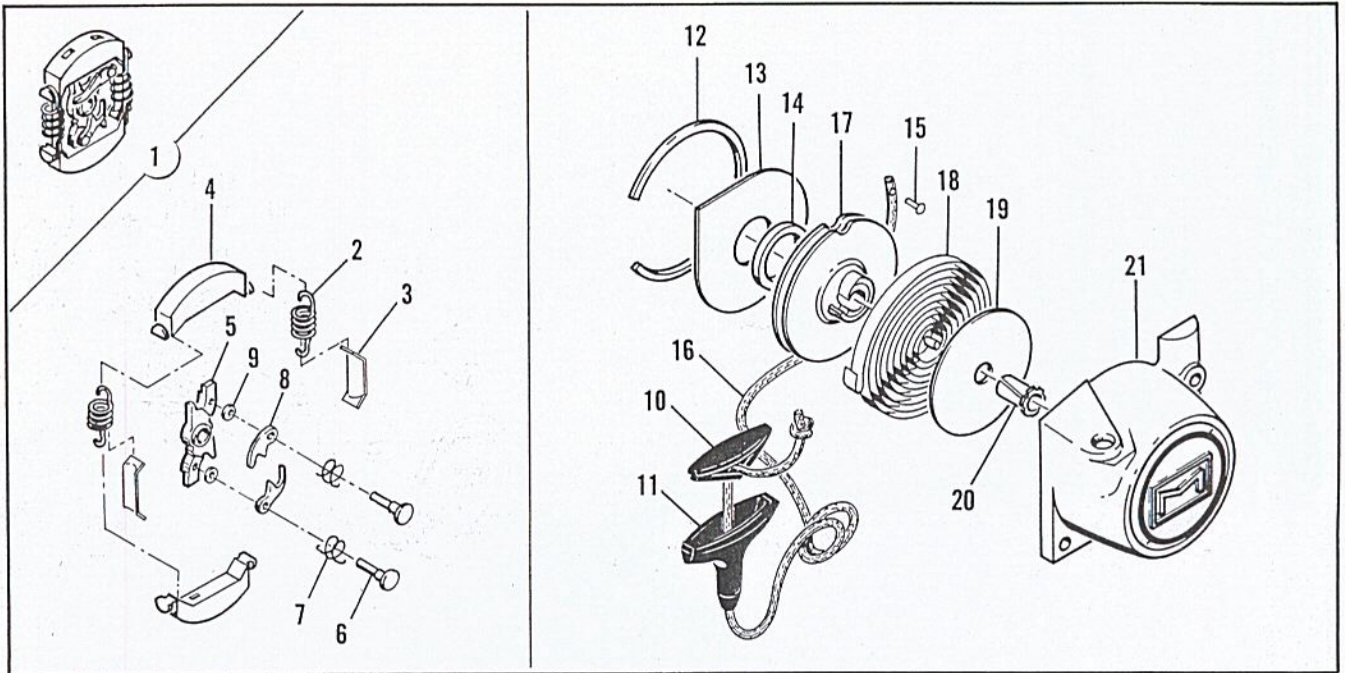

Figure 2. Clutch and Starter Assembly

## Figure 1. General (Continued)

Item No.	Part Number	Description	Units Per Assy	Usable on Code
56	68132	Gasket - Carburetor	1	All
57	66678	Spacer - Carburetor	1	All
58	68131	Gasket - Spacer	1	All
59	110570	Screw - Hex hd 12-24 x 1-3/8	2	All
60	68582	Lockplate	1	All
61	102115	Washer - #12	2	All
62	110568	Screw - Hex hd 12-24 x 1-1/8	1	All
63	69516	Lockplate	1	All
64	64856	Washer - Special	1	All
65	102660	Screw - Skt hd - 10-24 x 7/8	1	All
66	100003	Washer - #10	1	All
67	68219	Spacer - Fuel tank	1	All
68	106078	Screw - Pan hd 10-24 x 7/16	1	All
69	110566	Screw - Hex hd 12-24 x 5/8	1	All
70	68508	Lockplate	1	All
71	69838	Brace - Handle	1	All
72		Fuel Tank Assy (See Figure 3)		All
73	68580	Gasket - Fuel tank	2	All
74	68614	Insulator - Fuel tank	1	All
75	68863	Kit - Muffler	1	All
76	67838	. Screw - Muffler long	2	All
77	67837	. Screw - Muffler short	1	All
78	83993	. Lockplate	1	All
79	68838	. Muffler Assy	1	All
80	110563	. . Screw - Skt hd 8-32 x 1/4	2	All
81	83069	. . Stop - Reed	1	All
82	64785	. . Reed	1	All
83	63993	Gasket- Muffler screw	1	All
84	68149	Gasket - Muffler	1	All
85	68581	Insulator - Shroud	2	All
86	67910	Shroud	1	All
87		Powerhead Assy (See Figure 7)		

**Figure 2. Clutch and Starter Assemblies**

Item No.	Part Number	Description	Units Per Assy	Usable on Code								
Super LG-2 - Usable On Code												
<table border="1" style="width: 100%; border-collapse: collapse;"> <thead> <tr> <th style="width: 25%;">Letter</th> <th style="width: 25%;">A</th> <th style="width: 25%;">B</th> <th style="width: 25%;">C</th> </tr> </thead> <tbody> <tr> <td>Serial Numbers</td> <td>Prefix 11- All</td> <td>Prefix 12- 10001 - 10451</td> <td>Prefix 12- 10451 and Up</td> </tr> </tbody> </table>					Letter	A	B	C	Serial Numbers	Prefix 11- All	Prefix 12- 10001 - 10451	Prefix 12- 10451 and Up
Letter	A	B	C									
Serial Numbers	Prefix 11- All	Prefix 12- 10001 - 10451	Prefix 12- 10451 and Up									
1	67148	Clutch Assy . . . . .	1	A								
	83655	Clutch Assy . . . . .	1	B,C								
2	66384	. Spring - Clutch . . . . .	2	A								
	83223	. Spring - Clutch . . . . .	2	B,C								
3	64583	. Retainer - Spring . . . . .	2	All								
4	67233	. Shoe - Clutch . . . . .	2	All								
5	67149	. Rotor Assy . . . . .	1	A								
	83671	. Rotor Assy . . . . .	1	B,C								
6	67112	. . Rivet . . . . .	2	A								
	83653	. . Rivet . . . . .	2	B,C								
7	68837	. . Spring - Pawl . . . . .	2	A								
	83654	. . Spring - Pawl . . . . .	2	B,C								
8	64857	. . Pawl . . . . .	2	A								
	24093	. . Pawl . . . . .	2	B,C								
9	65473	. . Washer . . . . .	2	All								
	67058	Starter Assy . . . . .	1	A								
	83694	Starter Assy . . . . .	1	B,C								
10	62191A	. Insert - Handle . . . . .	1	All								
11	62190A	. Handle - Starter . . . . .	1	All								
12	67205	. Retainer - Shield . . . . .	1	All								
13	63985	. Shield - Dust . . . . .	1	All								
14	63986	. Washer - Thrust . . . . .	1	All								
15	110470	. Rivet - Rope . . . . .	1	All								
16	69964	. Rope - Starter . . . . .	1	All								
17	68695	. Drum - Starter . . . . .	1	A								
	83651	. Drum - Starter . . . . .	1	B,C								
18	68626	. Spring - Rewind . . . . .	1	A								
	83334	. Spring - Rewind . . . . .	1	B,C								
19	63987	. Shield - Spring . . . . .	1	All								
20	61635A	. Bushing - Nyliner . . . . .	1	All								
21	67059	. Housing - Starter . . . . .	1	All								

**SERVICE SPECIFICATIONS**

Spark Plug Gap -----	0.025 in.
Lamination Gap -----	0.010 to 0.015 in.
Breaker Point Gap -----	0.018 in.
Carburetor Adjustment	
Idle Needle - Preliminary adjustment 1 turn open.	
Adjust for smooth idle and acceleration.	
Main Needle - Preliminary adjustment 1 turn open.	
Adjust for maximum power under load.	
Torque Values	
Flywheel Nut -----	240 to 300 inch-pounds.
Clutch Nut -----	160 to 170 inch-pounds.
Connecting Rod Screws -----	65 to 70 inch-pounds.

# SUPER LG-2 Automatic

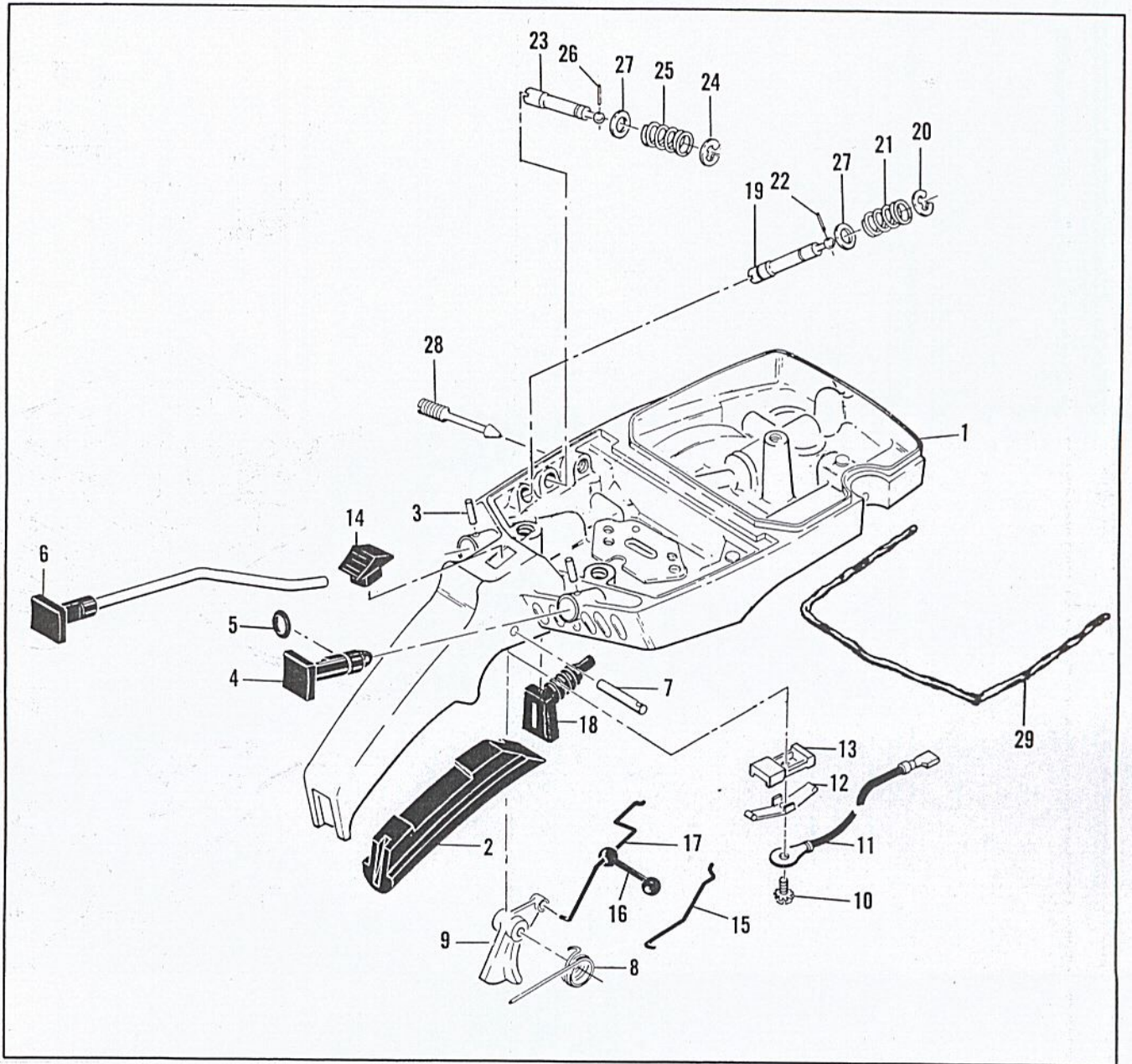

Figure 3. Fuel Tank Assembly

**Figure 3. Fuel Tank Assembly**

Item No.	Part Number	Description	Units Per Assy	Usable on Code								
Super LG-2 - Usable On Code												
<table border="1" style="width: 100%; border-collapse: collapse;"> <thead> <tr> <th style="width: 25%;">Letter</th> <th style="width: 25%;">A</th> <th style="width: 25%;">B</th> <th style="width: 25%;">C</th> </tr> </thead> <tbody> <tr> <td>Serial Numbers</td> <td>Prefix 11- All</td> <td>Prefix 12- 10001 - 10451</td> <td>Prefix 12- 10451 and Up</td> </tr> </tbody> </table>					Letter	A	B	C	Serial Numbers	Prefix 11- All	Prefix 12- 10001 - 10451	Prefix 12- 10451 and Up
Letter	A	B	C									
Serial Numbers	Prefix 11- All	Prefix 12- 10001 - 10451	Prefix 12- 10451 and Up									
1	68683	Fuel Tank Assy . . . . .	1	All								
2	64872	Grip - Handle . . . . .	1	All								
3	105673	Pin - Roll 3/32 x 9/16 . . . . .	2	All								
4	69041	Button - Choke . . . . .	1	All								
5	101056	"O" Ring . . . . .	1	All								
6	64871	Button & Rod Assy . . . . .	1	All								
7	110378	Pin - Roll 3/16 x 15/16 . . . . .	1	All								
8	65734	Spring - Throttle return . . . . .	1	All								
9	67224	Trigger . . . . .	1	All								
10	103672	Screw - Fil hd 8-32 x 1/2 . . . . .	1	All								
11	62973A	Wire Assy - Stop switch . . . . .	1	All								
12	62451	Contact - Switch . . . . .	1	All								
13	62950A	Base - Switch . . . . .	1	All								
14	62951	Button - Switch . . . . .	1	All								
15	69042	Rod - Choke . . . . .	1	All								
16	69043	Snubber - Control rod . . . . .	1	All								
17	68170	Rod - Throttle . . . . .	1	All								
18	68522	Seal - Throttle rod . . . . .	1	All								
19	68102	Extension Assy - High speed . . . . .	1	All								
20	110512	. Ring - Retaining . . . . .	1	All								
21	67363	. Spring . . . . .	1	All								
22	110509	. Pin - Groove . . . . .	1	All								
23	68101	Extension Assy - Idle . . . . .	1	All								
24	110512	. Ring - Retaining . . . . .	1	All								
25	67363	. Spring . . . . .	1	All								
26	110509	. Pin - Groove . . . . .	1	All								
27	67292	Washer . . . . .	2	All								
28	67271	Screw - Idle speed . . . . .	1	All								
29	* 69564	Seal - Airbox . . . . .	AR	All								

\* Furnished on a 12 - 1/2 inch strip containing 9 beads of sealant (enough for 9 replacements).





**Figure 4. Carburetor Assembly**

Item No.	Part Number	Description	Units Per Assy	Usable on Code								
Super LG-2 - Usable On Code												
<table border="1" style="width: 100%; border-collapse: collapse;"> <thead> <tr> <th style="width: 15%;">Letter</th> <th style="width: 25%;">A</th> <th style="width: 25%;">B</th> <th style="width: 35%;">C</th> </tr> </thead> <tbody> <tr> <td>Serial Numbers</td> <td>Prefix 11- All</td> <td>Prefix 12- 10001 - 10451</td> <td>Prefix 12- 10451 and Up</td> </tr> </tbody> </table>					Letter	A	B	C	Serial Numbers	Prefix 11- All	Prefix 12- 10001 - 10451	Prefix 12- 10451 and Up
Letter	A	B	C									
Serial Numbers	Prefix 11- All	Prefix 12- 10001 - 10451	Prefix 12- 10451 and Up									
	67379	Carburetor Assy . . . . .	1	A,C								
1	67501	. Screw - Pump cover . . . . .	4	A,C								
2	67484	. Cover - Pump . . . . .	1	A,C								
3	*67495	. Gasket - Cover . . . . .	1	A,C								
4	*83114	. Diaphragm - Fuel pump . . . . .	1	A,C								
5	*47690	. Screw - Plate . . . . .	3	A,C								
6	67487	. Plate - Throttle . . . . .	1	A,C								
7	67489	. Clip - Shaft . . . . .	1	A,C								
8	67486	. Shaft Assy - Throttle . . . . .	1	A,C								
9	67490	. Plate - Choke . . . . .	1	A,C								
10	67488	. Shaft Assy - Choke . . . . .	1	A,C								
11	*100302	. Ball - Choke friction . . . . .	1	A,C								
12	*67504	. Spring - Choke . . . . .	1	A,C								
13	*67506	. Needle - High speed . . . . .	1	A,C								
14	*67505	. Needle - Idle . . . . .	1	A,C								
15	*67502	. Spring - Needle . . . . .	2	A,C								
16	70798	. Screw - Diaphragm cover . . . . .	4	A,C								
17	67485	. Cover - Diaphragm . . . . .	1	A,C								
18	*67499	. Diaphragm - Metering . . . . .	1	A,C								
19	*67496	. Gasket - Diaphragm . . . . .	1	A,C								
20	*67500	. Screw - Lever pin . . . . .	1	A,C								
21	*67508	. Pin - Lever . . . . .	1	A,C								
22	*67509	. Lever - Metering . . . . .	1	A,C								
23	*67503	. Spring - Lever . . . . .	1	A,C								
24	*67491	. Valve - Needle . . . . .	1	A,C								
25	67483	. Body Assy - Carburetor . . . . .	1	A,C								
26	*67492	. . Plug - 3/8 . . . . .	1	A,C								
27	*69506	. . Plug - 5/16 . . . . .	1	A,C								
28	*69203	. . Seat Assy . . . . .	1	A,C								
29	*69204	. . Valve . . . . .	1	A,C								
30	*67507	. . Screen - Fuel . . . . .	1	A,C								
	*67482	Gasket Set . . . . .										
	67481	Repair Kit . . . . .										

\* Indicates parts included in Repair Kit, P/N 67481

**Figure 5. Carburetor Assembly**

Item No.	Part Number	Description	Units Per Assy	Usable on Code								
Super LG-2 - Usable On Code												
<table border="1" style="width: 100%; border-collapse: collapse;"> <thead> <tr> <th style="width: 15%;">Letter</th> <th style="width: 25%;">A</th> <th style="width: 25%;">B</th> <th style="width: 35%;">C</th> </tr> </thead> <tbody> <tr> <td>Serial Numbers</td> <td>Prefix 11- All</td> <td>Prefix 12- 10001 - 10451</td> <td>Prefix 12- 10451 and Up</td> </tr> </tbody> </table>					Letter	A	B	C	Serial Numbers	Prefix 11- All	Prefix 12- 10001 - 10451	Prefix 12- 10451 and Up
Letter	A	B	C									
Serial Numbers	Prefix 11- All	Prefix 12- 10001 - 10451	Prefix 12- 10451 and Up									
	69948	Carburetor Assy . . . . .	1	B								
1	52933	. Screw - Pump cover . . . . .	4	B								
2	66628	. Cover - Pump . . . . .	1	B								

(This list continued on page 11)

# SUPER LG-2 Automatic

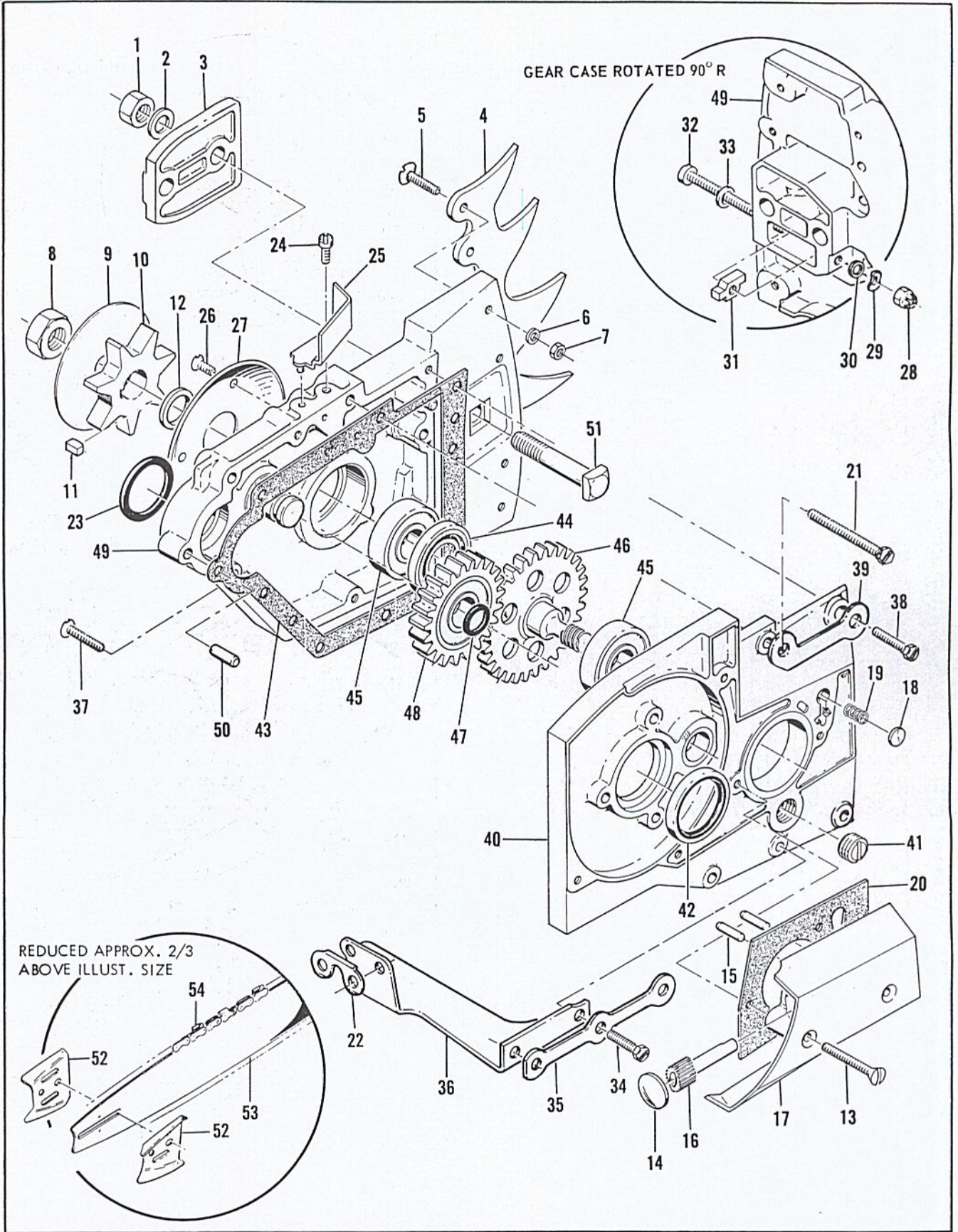

Figure 6. Transmission Assembly

**Figure 5. Carburetor Assembly (Continued)**

Item No.	Part Number	Description	Units Per Assy	Usable on Code
3	66629	. Gasket - Cover . . . . .	1	B
4	66630	. Diaphragm - Fuel pump . . . . .	1	B
5	48780	. Screw - Clip retainer . . . . .	1	B
6	66646	. Clip - Throttle shaft . . . . .	1	B
7	48780	. Screw - Plate . . . . .	1	B
8	51720	. Plate - Throttle . . . . .	1	B
9	83546	. Shaft Assy - Throttle . . . . .	1	B
10	67136	. Spring - Throttle return . . . . .	1	B
11	65856	. Plate - Choke . . . . .	1	B
12	83725	. Shaft Assy - Choke . . . . .	1	B
13	100071	. Ball - Choke friction . . . . .	1	B
14	52930	. Spring - Choke friction . . . . .	1	B
15	83477	. Needle - High speed . . . . .	1	B
16	52936	. Spring - High speed needle . . . . .	1	B
17	83547	. Needle - Idle . . . . .	1	B
18	67133	. Spring - Idle needle . . . . .	1	B
19	83549	. Valve Assy - Governor . . . . .	1	B
20	83548	. Gasket - Valve . . . . .	1	B
21	51721	. Screw - Diaphragm cover . . . . .	4	B
22	83724	. Cover - Diaphragm . . . . .	1	B
23	66632	. Diaphragm - Metering . . . . .	1	B
24	66633	. Gasket - Diaphragm . . . . .	1	B
25	83479	. Screw - Lever pin . . . . .	1	B
26	66636	. Pin - Lever . . . . .	1	B
27	66638	. Lever - Metering . . . . .	1	B
28	66404	. Spring - Lever . . . . .	1	B
29	66637	. Valve - Needle . . . . .	1	B
30	66623	. Screen - Fuel inlet . . . . .	1	B
31	83729	. Check Valve - Nozzle . . . . .	1	B
32	66622	. Plug - Welch . . . . .	1	B

**Figure 6. Transmission Assembly**

Item No.	Part Number	Description	Units Per Assy	Usable on Code								
Super LG-2 - Usable On Code												
<table border="1"> <tr> <th>Letter</th> <th>A</th> <th>B</th> <th>C</th> </tr> <tr> <th>Serial Numbers</th> <td>Prefix 11- All</td> <td>Prefix 12- 10001 - 10451</td> <td>Prefix 12- 10451 and Up</td> </tr> </table>					Letter	A	B	C	Serial Numbers	Prefix 11- All	Prefix 12- 10001 - 10451	Prefix 12- 10451 and Up
Letter	A	B	C									
Serial Numbers	Prefix 11- All	Prefix 12- 10001 - 10451	Prefix 12- 10451 and Up									
1	110625	Nut - Hex 3/8-24 . . . . .	2	All								
2	100006	Washer - 3/8 . . . . .	2	All								
3	63417	Plate - Bar clamp . . . . .	1	All								
4	63994	Kit - Spike . . . . .	1	All								
5	110245	. Screw - Fl hd 10-24 x 3/4 . . . . .	4	All								
6	110264	. Washer - #10 . . . . .	4	All								
7	101191	. Nut - Hex 10-24 . . . . .	4	All								
8	60972	Nut - Hex 7/16-20 . . . . .	1	All								
9	63997A	Plate - Sprocket . . . . .	1	All								
10	36644A	Sprocket . . . . .	1	All								
11	63808	Key - Sprocket . . . . .	1	All								
12	64754	Spacer - Sprocket . . . . .	1	All								
13	110406	Screw - Oval hd 8-32 x 1-1/4 . . . . .	2	All								
	65882	Pump Assy - Oil . . . . .	1	All								
14	105559	. Plug - welch . . . . .	1	All								
15	110392	. Pin - Plunger . . . . .	2	All								

(This list continued on page 13)

# SUPER LG-2 Automatic

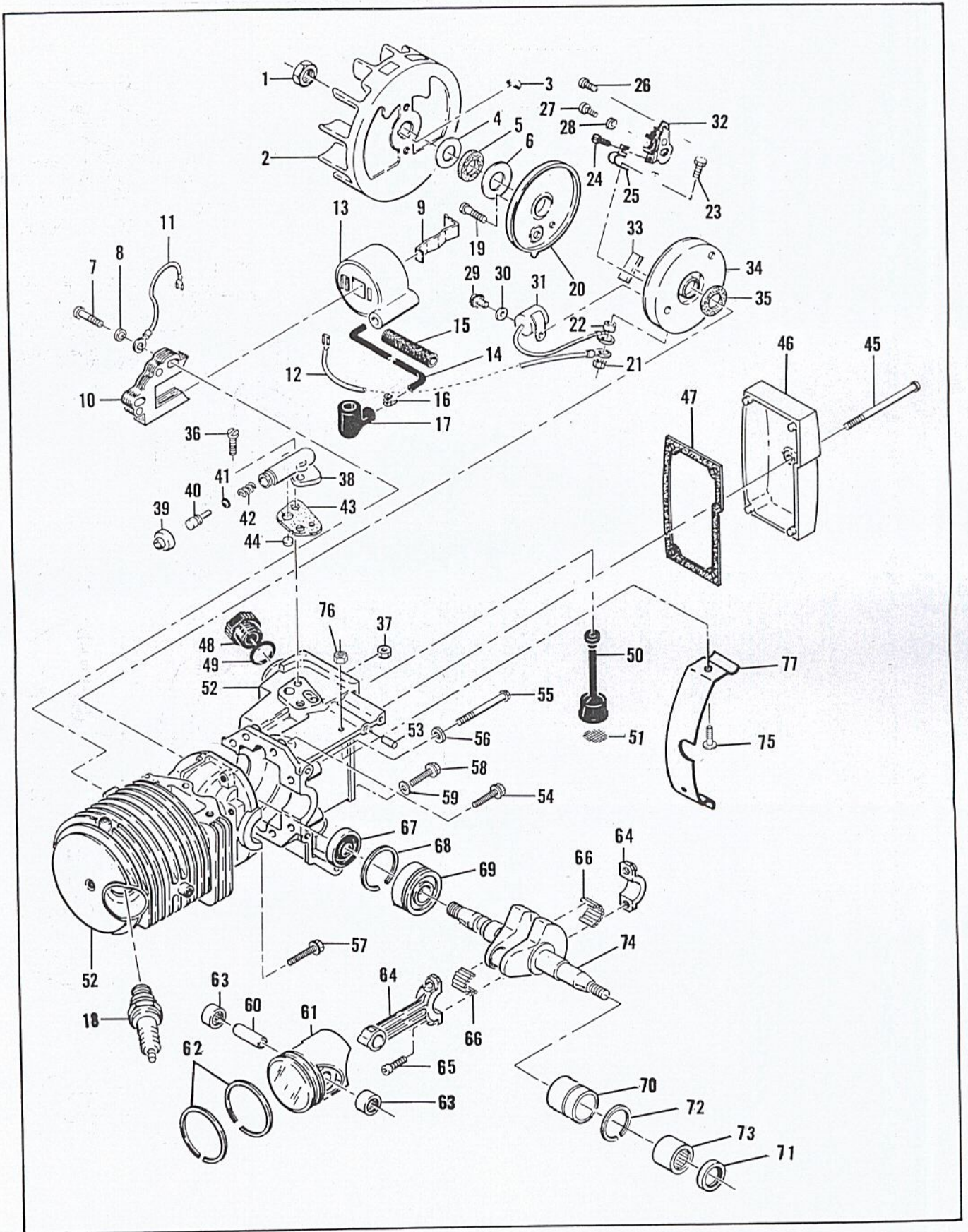

Figure 7. Powerhead Assembly

**Figure 6. Transmission Assembly (Continued)**

Item No.	Part Number	Description	Units Per Assy	Usable on Code
16	63428	. Plunger - Pump	1	All
17	65881	. Body - Pump	1	All
18	62909	Valve - Oiler	1	All
19	63692	Spring - Valve	1	All
20	63474	Gasket - Pump	1	All
21	102765	Screw - Hex hd 10-24 x 1-3/4	2	All
22	83455	Lockplate	1	All
	68487	Transmission Assy (3:1)	1	All
23	104360	. "O" Ring	1	All
24	110055	. Screw - Fil hd 8-32 x 3/8 (SEMS)	1	All
25	63491	. Filler	1	All
26	110417	. Screw - Fl hd 6-32 x 3/8	3	All
27	63416	. Plate - Sprocket	1	All
28	102067	. Nut - Hex 10-24	1	All
29	110387	. Washer - Wave	1	All
30	100003	. Washer - #10	1	All
31	63824A	. Nut - Bar Adjustment	1	All
32	110548	. Screw - Bar adjustment	1	All
33	110264	. Washer	1	All
34	102290	. Screw - Hex hd 10-24 x 1-1/8	1	All
35	83457	Lockplate	1	All
36	67066	. Brace - Gearcase	1	All
37	110405	. Screw - Oval hd 8-32 x 7/8	3	All
38	102760	. Screw - Hex hd 10-24 x 1	2	All
39	83456	Lockplate	1	All
40	68490	. Cover Assy - Gearcase (3:1)	1	All
41	100432	. . Plug - Filler	1	All
42	63477	. . Seal - Pinion gear	1	All
43	68576	. Gasket - Cover	1	All
44	63478	. Seal - Gearcase	1	All
45	110348	. Bearing - Sprocket shaft	2	All
46	64775	. Gear - Sprocket	1	All
47	110452	. "O" Ring	1	All
48	66616	. Gear Assy - Idler	1	All
49	68488	. Gearcase (3:1)	1	All
50	101770	. . Pin - Dowel	2	All
51	64584	. . Bolt - Bar	2	All
52	64935	Plate - Bar protector	2	All
53		Bar	1	All
54		Chain Assy	1	All

**Figure 7. Powerhead Assembly**

Item No.	Part Number	Description	Units Per Assy	Usable on Code								
Super LG-2 - Usable On Code												
<table border="1"> <tr> <th>Letter</th> <th>A</th> <th>B</th> <th>C</th> </tr> <tr> <th>Serial Numbers</th> <td>Prefix 11- All</td> <td>Prefix 12- 10001 - 10451</td> <td>Prefix 12- 10451 and Up</td> </tr> </table>					Letter	A	B	C	Serial Numbers	Prefix 11- All	Prefix 12- 10001 - 10451	Prefix 12- 10451 and Up
Letter	A	B	C									
Serial Numbers	Prefix 11- All	Prefix 12- 10001 - 10451	Prefix 12- 10451 and Up									
1	110594	Nut - Hex 3/8-24	1	All								
2	61737A	Flywheel Assy	1	All								
3	103879	Key - Woodruff	1	All								
4	67057	Washer - Thrust	1	All								
5	67056	Seal	1	All								

(This list continued on page 14)

# SUPER LG-2 Automatic

## Figure 7. Powerhead Assembly (Cont.)

Item No.	Part Number	Description	Units Per Assy	Usable on Code
6	67054	Washer - Thrust . . . . .	1	All
7	110127	Screw - Fil hd 10-24 x 7/8 . . . . .	2	All
8	100003	Washer - #10 . . . . .	2	All
9	51253	Retainer - Coil . . . . .	1	All
10	68164	Lamination Assy . . . . .	1	All
11	62819	Wire Assy - Ground . . . . .	1	All
12	69344	Wire Assy - Primary . . . . .	1	All
13	69798	Coil & Terminal Assy . . . . .	1	All
14	69966	. Wire Assy - Spark plug . . . . .	1	All
15	67127	. . Sleeve . . . . .	1	All
16	62932	. . Connector . . . . .	1	All
17	62926	. . Boot . . . . .	1	All
18	63097	Spark Plug - AC CS45T . . . . .	1	All
19	110349	Screw - Rd hd 8-32 x 3/4 . . . . .	1	All
20	62362	Cover - Breaker box . . . . .	1	All
21	100298	Nut - Hex 6-32 . . . . .	1	All
22	62365	Spacer - Breaker screw . . . . .	1	All
23	110346	Screw - Hex hd 6-32 x 3/4 . . . . .	1	All
24	110489	Screw - Pan 6-32 x 7/16 . . . . .	1	All
25	83126	Strap - Conduction . . . . .	1	All
26	100934	Screw - Rd hd 8-32 x 3/8 . . . . .	1	All
27	110445	Screw - Tr hd 8-32 x 3/8 . . . . .	1	All
28	105976	Washer - #8 . . . . .	1	All
29	103672	Screw - Fil hd 8-32 x 1/2 . . . . .	1	All
30	100080	Washer - #8 . . . . .	1	All
31	61650	Condenser . . . . .	1	All
32	66231	Breaker Assy . . . . .	1	All
33	54184	Wiper - Cam . . . . .	1	All
34	83125	Box - Breaker . . . . .	1	All
35	67051	Seal - Box . . . . .	1	All
36	110623	Screw - Fil hd 8-32 x 1/2 . . . . .	2	All
37	100955	Nut - Hex 8-32 . . . . .	1	All
38	62261A	Housing - Pump . . . . .	1	All
39	62262	Cap - Housing . . . . .	1	All
40	62266	Plunger - Pump . . . . .	1	All
41	101056	"O" Ring . . . . .	1	All
42	66687	Spring - Plunger . . . . .	1	All
43	62230	Gasket - Pump . . . . .	1	All
44	62909	Valve - Pump . . . . .	1	All
45	110407	Screw - Pan hd 10-24 x 3-1/2 . . . . .	1	All
46	63974	Cover - Oil tank . . . . .	1	All
47	63442	Gasket - Cover . . . . .	1	All
48	68809	Cap . . . . .	1	All
49	101148	"O" Ring . . . . .	1	All
50	62123B	Hose Assy - Oil . . . . .	1	All
51	51506	. Screen - Hose . . . . .	1	All
52	68824	Crankcase Assy . . . . .	1	All
53	105826	. Pin - Roll . . . . .	1	All
54	110288	. Screw Assy - 8-32 x 3/4 . . . . .	2	All
55	62105	Screw Assy - Sealing . . . . .	4	All
56	62842	. Washer - Sealing . . . . .	4	All
57	110404	Screw Assy - 8-32 x 7/8 . . . . .	1	All
58	63607	Screw Assy - Sealing . . . . .	1	All
59	63606	. Washer - Sealing . . . . .	1	All
60	61649	Pin - Piston . . . . .	1	All
61	69212	Piston Assy . . . . .	1	All
62	62814	. Ring Set - Piston . . . . .	1	All
63	103512	. Bearing - Needle . . . . .	2	All
64	65401	Connecting Rod Assy . . . . .	1	All
65	61627A	. Screw - Skt hd 8-36 x 1/2 . . . . .	2	All
66	63225	. Roller - Needle (set of 20) . . . . .	1	All
67	67906	Oil Seal . . . . .	1	All

(This list continued on page 15)

**Figure 7. Powerhead Assembly (Cont.)**

Item No.	Part Number	Description	Units Per Assy	Usable on Code
68	63464	Ring - Snap	1	All
69	67905	Bearing - Ball	1	All
70	63492	Insert & Bearing Assy	1	All
71	110260	. Oil Seal	1	All
72	63699	. Ring - Insert	1	All
73	104357	. Bearing - Needle	1	All
74	68505	Crankshaft	1	All
75	105221	Screw - Rd hd 10-24 x 5/16	2	All
76	101191	Nut - Hex 10-24	2	All
77	65363	Guard - Crankcase	1	All

**Accessories**

Part Number	Description
83434	Manual - Owner's
61040	Wrench - Screwdriver
63746	"Scrench" (Spark plug)
65712	Guide - Timing
68052	Plate - Wear
65778	Spark Plug - AC CS41T
63432	Spark Plug - AC CS42T
83406	Kit - Spark arrester screen
69210	Piston Assy - 0.020 in. oversize
62813	. Ring Set - Piston 0.020 in. oversize
103512	. Bearing - Needle (2)
69211	Piston Assy - 0.030 in. oversize
62812	. Ring Set - Piston 0.030 in. oversize
103512	. Bearing - Needle (2)
68585	Transmission 2:1