

ILLUSTRATED PARTS LIST

MCCULLOCH MODELS
600016-01 17
600016-02 17-18
600016-03 17-18
600016-04 17-18
600016-05 17
600016-06 17
600016-07 17-18
600016-08 18
600016-11 17-18
600016-12 17
600016-13 17-18
600016-14 17-18
600016-15 17
600016-16 17
600016-17 17
600016-20 17-18
600016-27 18
600124-02 12
600124-03 12

EAGER BEAVER® MODELS
600123-02 11-12
600123-03 11-12
600123-04 11-12
600123-05 11-12
600123-06 11-12
600123-07 11-12
600123-08 11-12
600123-09 11-12
600123-10 11-12
600124-04 12
600124-06 12

MCCULLOCH 100 SERIES & 160S EAGER BEAVER® & EAGER BEAVER® SUPER 16 CHAIN SAWS

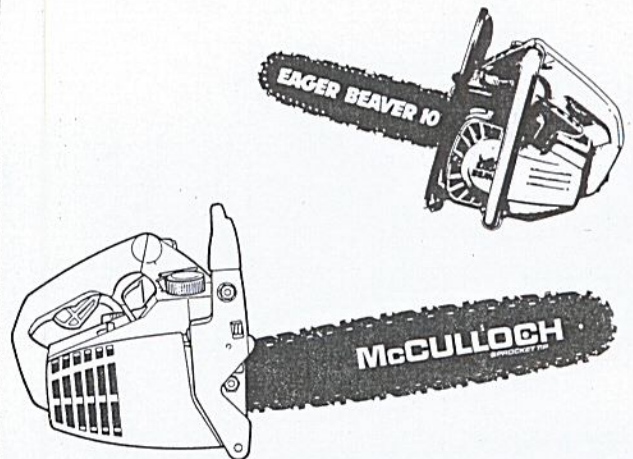

Eager Beaver® and McCulloch Chain Saws are identified by a model number (in this instance 600016, 600123, or 600124) followed by a suffix number (01, 02, 03, etc.) stamped on the identification decal attached to the unit. Suffix numbers denote variations in parts or assemblies used in the manufacture of this product.

Part numbers listed in this I.P.L. which have a circled number ② or numbers preceding the description, are used only on the model or models identified by a circled number ② or numbers.

Part numbers which have one or more dots (.) preceding their descriptions may be ordered individually, but they are also included in the kit or assembly whose description begins directly above the dot(s).

The policy of McCulloch Corporation is one of continual improvement in design, manufacturing and engineering advancement wherever possible to assure still finer two-cycle power tools. Hence, specifications, equipment, colors, design and manufacturer's suggested list prices are subject to change without notice and McCulloch Corporation reserves the right to make such changes without prior notification or obligation to backfit or supply backfit components for units previously shipped from the factory.

- CONTENTS -

	Page
FIGURE 1 GENERAL ASSEMBLY	2
BAR/CHAIN & CHAIN SHARPENING TOOLS	3
FIGURE 2 CARBURETOR ASSEMBLY (Zama)	4
FIGURE 3 CARBURETOR ASSEMBLY (Walbro)	5
FIGURE 4 POWERHEAD ASSEMBLY	6
FIGURE 5 CHAIN BRAKE ASSEMBLY	8
SPECIFICATIONS	8
ACCESSORIES	9

MARCH 1987

MCCULLOCH
CORPORATION

© U.S.A. - McCulloch Corporation, 1987

Printed in U.S.A.

219239

(THIS IPL SUPERSEDES AND REPLACES IPL'S, P/N 217013 and 217019)

Figure 1 GENERAL ASSEMBLY

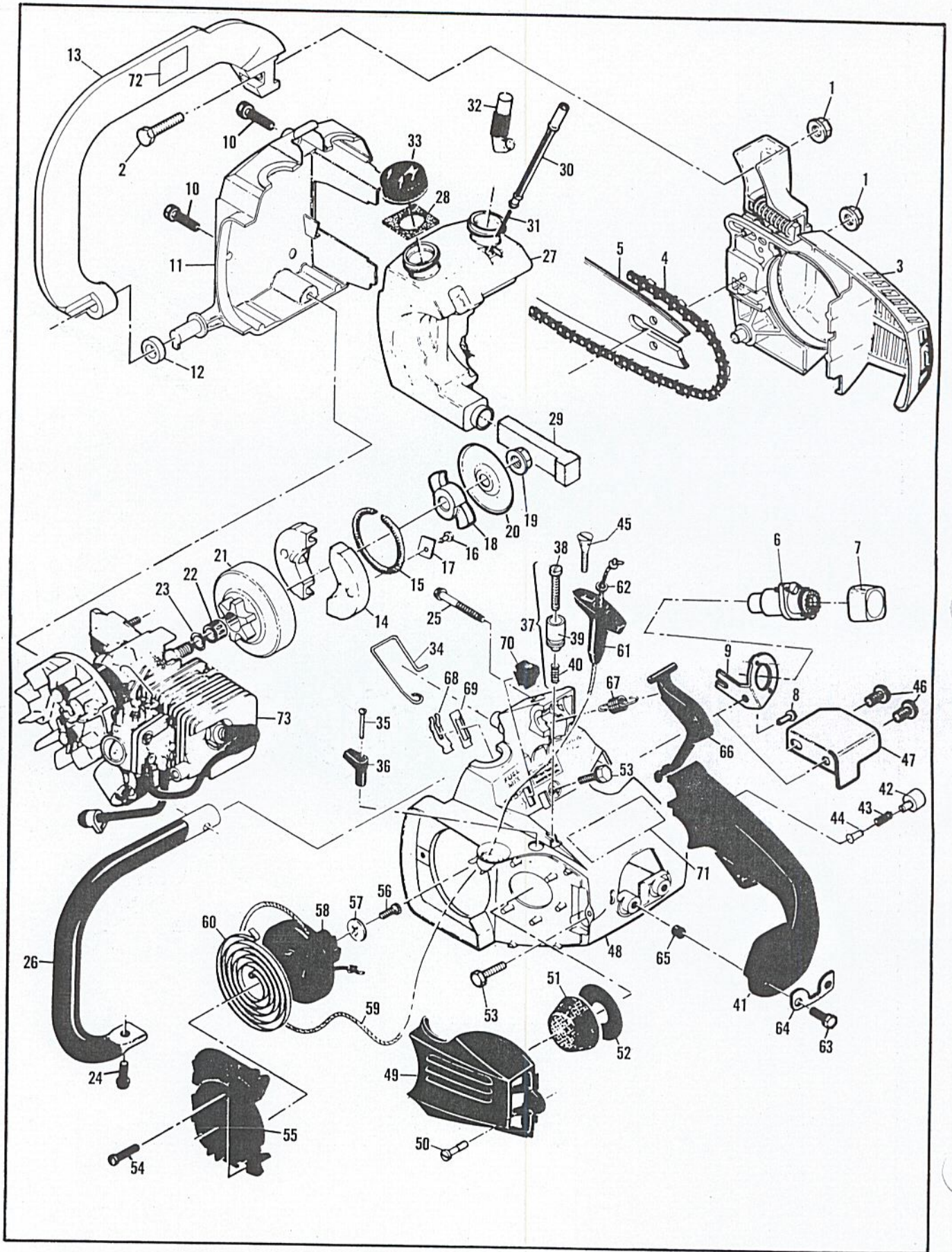

FIGURE 1 GENERAL ASSEMBLY

ITEM NO.	PART NUMBER	DESCRIPTION	UNITS PER ASY.
1	110676	Nut-Hex Head 1/4-28 (65-75 in. lb. torque)	2
2	110972	Screw-Hex 1/4-28x3/4	1
3	Fig. 5	Chain Brake Assembly	1
4	(SEE BELOW)	Saw Chain	1
5	(SEE BELOW)	Guide Bar	1
6	① 218886	Grinder Assembly	1
7	① 215447	Knob - Auto-Sharp	1
8	① 110583	Screw-Pn Hd 8-32 x 44 (35-40 in. lb. torque)	2
9	① 215209	Bracket - Auto-Sharp	1
10	110639	Screw-Hex Hd 12-24 x 1 (55-60 in. lb. torque)	2
11	218867	Cover-Fuel/Oil Tank	1
12	93194-01	Washer-Rubber	1
13	92479	Lever/Handguard	1
14	213278	Kit-Clutch	1
15	93608	. Spring-Assembly	1
16	110957	. Rivet-Flt. 1/8 x .547	2
17	85064	. Plate	2
18	94247	. Kit-Rotor	1
19	94244	. . Nut-Clutch (160-170 in. lb. torque)	1
20	94243	. . Plate-Dust	1
21	215252	Drum/Sprocket/Bearing Assembly	1
22	91222	. Kit-Needle Bearing	1
23	215259	Spacer-Drum	1
24	110953	Screw-Hx Hd 12-24 x 5/8 (70-80 in. lb. torque)	1
25	110686	Screw-Hx Hd 13-16 x 2 (35-45 in. lb. torque)	1
26	214505	Frame/Grip Assembly	1
27	217761	Kit-Fuel/Oil Tank	1
28	91148	. Seal-Fuel Vent	1
29	84956	. Pickup-Fuel	1
30	217755	. Piston-Manual Oiler	1
31	83946	. Spring-Piston	1
32	85557	. Body-Oiler	1
33	216668	Cap-Fuel/Oil	2
34	217759	Rod-Manual Oiler	1
35	110672	Screw-Oval Hd 4-40 x 1	1
36	83870	Knob-Choke	1
37	② 93437	Latch Assembly-Throttle	1
38	② -- --	. Screw-Long Neck	1

① Used on units equipped with Auto Sharp™.

② Used on models with Throttle Latch on the carburetor.

ITEM NO.	PART NUMBER	DESCRIPTION	UNITS PER ASY.
39	② -- --	. Latch-Throttle	1
40	② -- --	. Spring-Compression	1
41	② 217908	Handle/Safety Trigger Assembly	1
	③ 218130	Handle/Safety Trigger/Throttle Latch Assembly	1
42	③ -- --	. Knob-Throttle Latch	1
43	③ -- --	. Spring-Throttle Latch	1
44	③ -- --	. Rivet-Flat	1
45	③ 68566	Screw-Idle Adjustment	1
46	110807	Screw-Pan Hd 8-32 x .312 (35-50 in. lb. torque)	2
47	93290	Deflector-Sawdust	1
48	① 217015	Shroud-Using Auto Sharp	1
	216963	Shroud-Non Auto Sharp	1
49	91851	Cover-Air Filter	1
50	91796	Screw-Filter Cover	1
51	216905	Filter-Air	1
52	84918	Washer-Air Seal	1
53	216490	Screw-Hex Hd 12-24 x .76 (70-80 in. lb. torque)	3
54	110959	Screw-Hex Hd 8-32 x .50 (25-30 in. lb. torque)	3
55	90425	Housing-Starter	1
56	110041	Screw-Pan Hd 8-32 x .50 (20-25 in. lb. torque)	1
57	68497	Washer-Special	1
58	④ 213257	Drum/Rope Assembly	1
59	83203	. Rope-Starter	1
60	83078	Spring-Rewind	1
61	91255	Kit-Starter Handle	1
62	105490	. Washer-Starter Handle	1
63	110953	Screw-Hex Hd 12-24 x .625 (20-25 in. lb. torque)	2
64	84520-01	Plate-Washer	1
65	84519	Sleeve-Handle	2
66	217909	Trigger-Throttle	1
67	83940	Spring-Trigger Return	1
68	83935	Contact-Switch	1
69	83936	Protector-Switch	1
70	83934	Button-Switch	1
71	218853-01	Decal-2.0 Cu. In.	1
	218884-01	Decal-Name Eager Beaver	1
72	219058	Label-Safety	1
73	Fig.4	Powerhead Asy.	1

③ Used on models with Throttle Latch on the handle.

④ Also Included In Starter Drum/Pawl Kit, p/n 213261. See Service Bulletin 1833.

Bar/Chain & Chain Sharpening Tools

BAR NUMBER	BAR DESCRIPTION	CHAIN NUMBER	CHAIN DESCRIPTION	FILE PLATE NUMBER	ROUND FILE SIZE	ROUND FILE PART NUMBER
214233	10" Mini Pro	214923-12	MP370GLX 38CL	219131	5/32"	214217 * 62648-23 **
214234	12" Mini Pro	214921-12	MP370GLX 44CL	219131	5/32"	214217 * 62648-23 **
214235	14" Mini Pro	214919-12	MP370GLX 49CL	219131	5/32"	214217 * 62648-23 **
214236	16" Mini Pro	214925-12	MP370GLX 54CL	219131	5/32"	214217 * 62648-23 **

* TWIN PACK ** DOZEN PACK

Figure 2

CARBURETOR ASSEMBLY

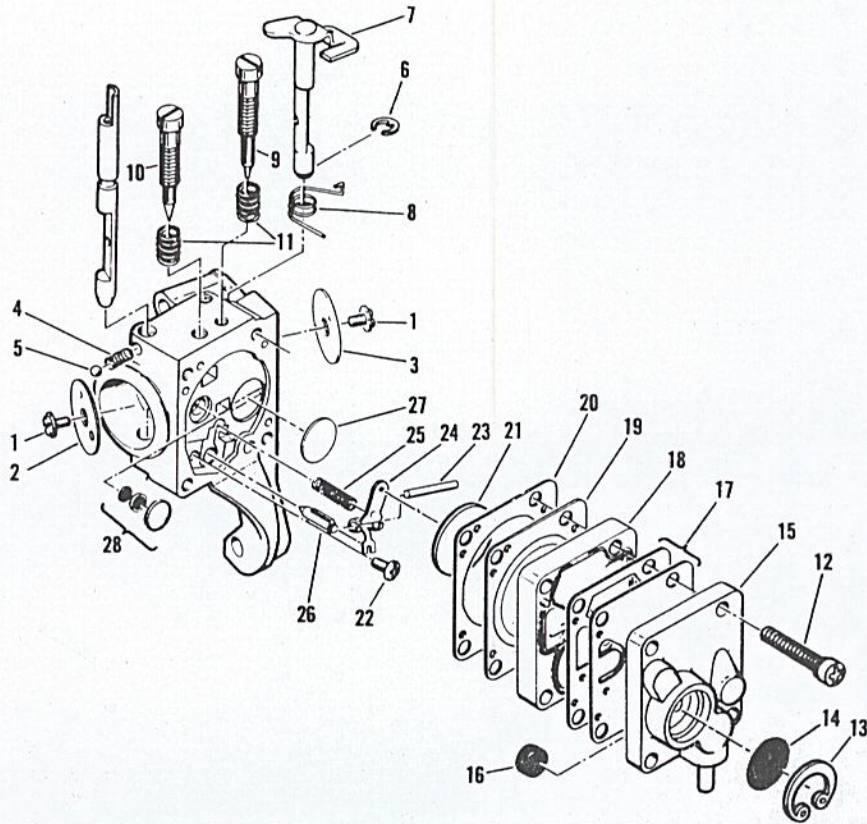

ZAMA - M1-M7

ITEM NO.	PART NUMBER	DESCRIPTION	UNITS PER ASY.
	214082-01	① Carburetor Assy-Zama M1-M7	1
1	- -	. Screw - Plate	2
2	- -	. Valve - Choke	1
3	- -	. Valve - Throttle	1
4	- -	. Spring - Choke	1
5	- -	. Ball - Friction	1
6	- -	. "E" Ring	1
7	- -	. Shaft Assembly - Throttle	1
8	- -	. Spring - Throttle Return	1
9	- -	④ . Screw - Idle Adjustment	1
10	- -	④ . Screw - Main Adjustment	1
11	- -	④ . Spring - Screw	2
12	- -	. Screw - Cover	4
13	- -	. "C" Ring	1
14	- -	② . Strainer	1

ITEM NO.	PART NUMBER	DESCRIPTION	UNITS PER ASY.
15	- -	. Cover - Pump	1
16	- -	② . Screen	1
17	- -	③② . Kit - Pump diaphragm	1
18	- -	. Body - Pump	1
19	- -	③② . Diaphragm - Main	1
20	- -	③② . Gasket - Main	1
21	- -	② . Disk	1
22	- -	② . Screw	1
23	- -	② . Pin - Arm	1
24	- -	② . Arm - Needle Valve	1
25	- -	② . Spring - Arm	1
26	- -	② . Valve - Needle	1
27	- -	② . Plug - Welch	1
28	- -	② . Valve Asy - Main Nozzle	1

NOTE

Individual parts are shown for identification and disassembly sequence purposes only and are not available as service replacement parts. The only items available for service are those parts listed in respective repair kits.

① One of two carburetors used alternately. Identify carburetor before ordering repair kits.

② Contained in Repair Kit, P/N 217079.

③ Contained in Gasket/Diaphragm Kit, P/N 216722.

④ Contained in Needle Kit, P/N 217086.

CARBURETOR ASSEMBLY

Figure 3

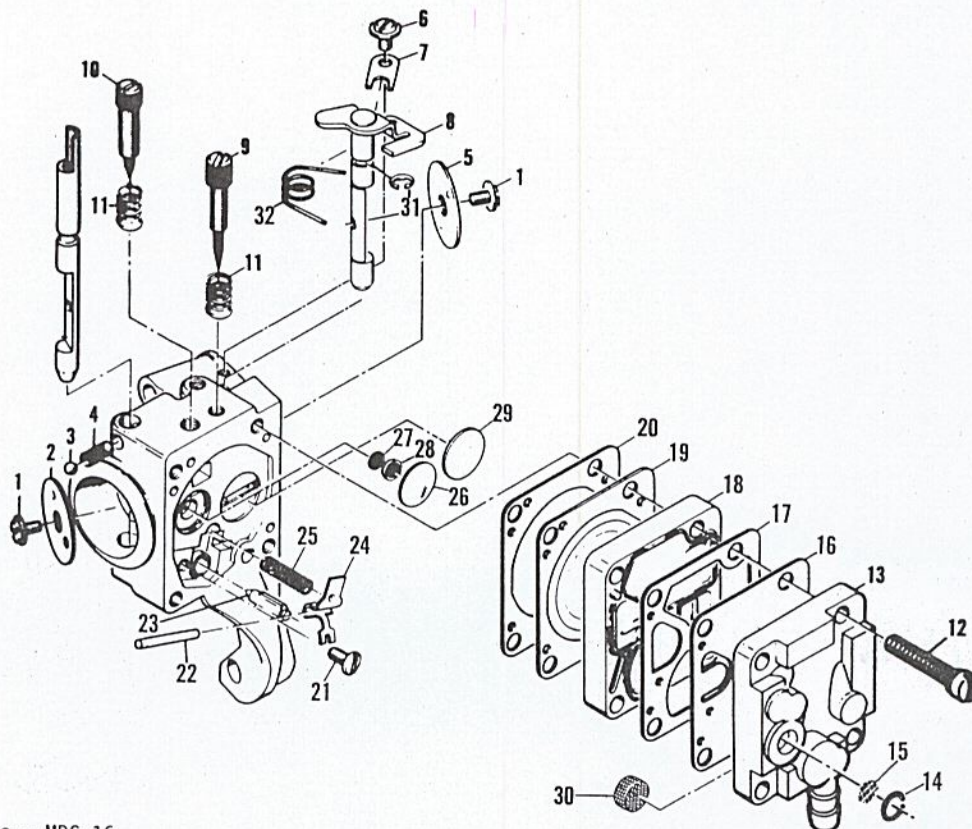

Walbro - MDC 16

ITEM NO.	PART NUMBER	DESCRIPTION	UNITS PER ASY.
	214082-01	① CARBURETOR ASSY - WALBRO MDC 16	
1	-- -- ②	. SCREW - PLATE	2
2	-- --	. PLATE - CHOKE	1
3	-- -- ②	. BALL - CHOKE FRICTION	1
4	-- -- ②	. SPRING - CHOKE FRICTION	1
5	-- --	. PLATE - THROTTLE	1
6	-- --	. SCREW - CLIP	1
7	-- --	. CLIP - THROTTLE SHAFT	1
8	-- --	. SHAFT ASSEMBLY - THROTTLE	1
9	-- -- ②	. NEEDLE - IDLE	1
10	-- -- ②	. NEEDLE - HIGH SPEED	1
11	-- -- ②	. SPRING - NEEDLE	2
12	-- -- ②	. SCREW ASSEMBLY - BODY	4
13	-- --	. COVER ASSEMBLY - PUMP	1
14	-- -- ②③	. RING - VENT SCREEN	1
15	-- -- ②③	. VENT - SCREEN	1
16	-- -- ②③	. DIAPHRAGM - FUEL PUMP	1

ITEM NO.	PART NUMBER	DESCRIPTION	UNITS PER ASY.
17	-- -- ②③	. GASKET - METERING DIAPHRAGM	1
18	-- --	. BODY - FUEL PUMP	1
19	-- -- ②③	. DIAPHRAGM ASSEMBLY - METERING	1
20	-- -- ②③	. GASKET - FUEL PUMP	1
21	-- -- ②③	. SCREW - METERING LEVER PIN	1
22	-- -- ②③	. PIN - METERING LEVER	1
23	-- -- ②③	. VALVE - INLET NEEDLE	1
24	-- -- ②③	. LEVER - METERING	1
25	-- -- ②③	. SPRING - METERING LEVER	1
26	-- -- ②③	. PLUG - WELCH 7/16	1
27	-- -- ②③	. SCREEN - INLET	1
28	-- -- ②	. RING - INLET SCREEN	1
29	-- -- ②③	. PLUG - WELCH 1/2	1
30	-- -- ②③	. SCREEN	1
31	-- -- ②③	. RING - RETAINING	1
32	-- --	. SPRING - THROTTLE RETURN	1

NOTE

Individual parts are shown for identification and disassembly sequence purposes only and are not available as service replacement parts. The only items available for service are those listed in respective repair kits.

- ① One of two carburetors used alternately. Identify carburetor before ordering repair kits.
- ② Contained in Major Repair Kit, P/N 217084.
- ③ Contained in Minor Repair Kit, P/N 216727.

FIGURE 4 POWERHEAD ASSEMBLY

ITEM NO.	PART NUMBER	DESCRIPTION	UNITS PER ASY.
1	① 86438	Valve-Check	1
2	① 217156	Connector-Oil Tank/Bar Pad	1
3	① 105603	"0" Ring-Connector Spacer	1
4	② 217168	Connector-Pump/Bar Pad	1
5	② 217167	Connector-Pump/Oil Tank	1
6	② 83896	Bail-Pump Retaining	1
7	② 216563	Automatic Oil Pump Assembly	1
8	② 83891	. Spring-Return	1
9	② 110651	. Screw-Oil Flow Adjustment	1
10	② -- --	. Body-Pump	1
11	② 216426	. Kit-Oil Pump Repair	1
12	② 105603	. . "0" Ring-.114 x .070	1
13	② -- --	. . Ring-Oil Pump Piston	1
14	② -- --	. . Piston Assembly-Oiler	1
15	② -- --	. . Sleeve-Oil Pump	1
16	② -- --	. . Eyelet	1
17	② 110653	"0" Ring-Pump/Crankcase	1
18	③ 215411	Muffler Assembly	1
19	③ 110681	. Screw-Skt. Hd. 10-24 x .250 (40-45 in. lb. torque)	2
20	③ 92961	. Deflector-Exhaust	1
21	③ 213327	. Screw-Special (70-80 in. lb. torque)	2
22	③ 214204	Kit-Spark Arrestor Screen	1
23	③ 101987	. Screw-6-32 x .250	1
24	④ 215871	Nut-Muffler (40-60 in. lb. torque)	2
25	④ 215471	Plate-Lock	1
26	④ 215472	Deflector-Exhaust	1
27	④ 216805	Screen-Spark Arrestor	1
28	④ 215774	Cover	1
29	④ 215776	Baffle	1
30	④ 213369	Screw-Hex Wsh M6 (70-85 in. lb. torque)	1
31	④ 215757	Bolt-Shoulder (65-85 in. lb. torque)	2
32	④ 215773	Base	1
33	⑤ 62345	Spark Plug-CS45T AC	1
	⑥ 92879	Spark Plug-RDJ8J CH	1
34	216039	Rod-Throttle	1
35	89059	Hose-Fuel	1
36	90660	Adaptor-Fuel Hose	1
37	110908	"0" Ring-Adaptor	1
38	216640	Nut-Hex 5/16-24 (200-220 in. lb. torque)	1
39	94737	Flywheel/Pawl Assembly	1
40	⑦ 216984	. Pin-Pawl	2
41	⑦ 216982	. Spring-Pawl	2
42	⑦ 93469	. Washer-Pawl	2
43	⑦ 216983	. Pawl-Starter	2
44	102164	Key-Woodruff	1
45	110586	Screw-Pan Head 8-32 x 1.75	3
46	105976	Washer-No. 8 Plain	3

ITEM NO.	PART NUMBER	DESCRIPTION	UNITS PER ASY.
47	67177	Washer-Insulating	3
48	68198	Tube-Insulating	3
49	Fig. 3	Carburetor Assembly	1
50	68197	Gasket-Carburetor	1
51	⑧ 219389	Connector/Insulator Assy	1
52	⑧ 219754	. Insulator-Carburetor	1
53	⑧ 219753	. Screw-Connector	1
54	⑧ 219390	. Connector-Stop Switch	1
55	⑧ 213032	Screw-Hex HD 8-32 x 1/2	1
56	⑧ 217758	Connector-Stop Switch	1
57	⑧ -- --	. Eyelet-Connector	1
58	90714	Gasket-Insulator	1
59	⑨ 84957	Coil-Lamination Assembly	1
60	⑨ 215351	. Wire Assembly-Spark Plug	1
61	⑨ 110364	Screw-Pan Head 6-32 x 5/8	1
62	⑨ 69344	Wire Assembly Coil	1
63	⑨ 110041	Screw-Pan Head 8-32 x 1/2	1
64	⑨ 85358	Condenser	1
65	⑨ 100035	Nut-Hex 6-32	1
66	⑨ 84502	Connector-Stop Switch	1
67	⑨ 67841	Cover-Breaker Box	1
68	⑨ 69323	Seal-Breaker Box	1
69	⑨ 213032	Screw-Hex Head 8-32 x 1/2	2
70	⑨ 69322	Washer-Special	1
71	⑨ 105976	Washer-No. 8	1
72	⑨ 88811	Breaker-Assembly	1
73	⑨ 84505-01	Kit-Breaker Box	1
74	⑨ 92037	. Washer	1
75	⑩ 217031	Electronic Ignition Assembly	1
76	⑩ 217190	Wire Assembly-Stop Switch	1
77	⑪ 217165	Cylinder/Crankcase Using Auto Sharp	1
	216935	Cylinder/Crankcase Using Automatic Oiler	1
	217067	Cylinder/Crankcase Without Automatic Oiler	1
	⑫ 216950	Cylinder/Crankcase Using Automatic Oiler	1
78	120097	. Screw-Hex M5 x 0.8 x 25 (70-80 in. lb. torque)	4
79	83856	. Bolt-Bar Mounting	1
80	110914	. Plug-Cup	4
81	94662	Piston Assembly	1
	⑬ 216713	Piston Assembly	1
82	95143	. Set-Piston Rings	1
	⑬ 216705	. Set-Piston Rings	1
83	92836	. Pin-Piston	1
84	111026	. Ring-Snap	2
85	94135	Connecting Rod Assembly	1
86	94654	. Screw-Connecting Rod	2
87	68095	. Roller-Needle (set of 20)	1
88	110984	. Bearing-Needle	1
89	⑬ 213282	Bearing-Crankshaft	2
90	⑬ 83859	Seal-Crankshaft	2
91	217029	Crankshaft	1

① Used on units with manual oiler only.

② Used on units equipped with automatic oiler.

③ Used on Mac[™] 110-03, 04, 05 and 08; Mac[™] 120-02 and 11; Mac[™] 130-07, 13 and 20; All Eager Beaver[®] models.

④ Used on Mac[™] 110-01, 03, 04, 07, 08, 11, 13, 14, 20 and 27; Mac[™] 120-02; Mac[™] 130-06, 07, 20; All Eager Beaver[®] models.

⑤ Used on Mac[™] 110-01, 03 and 08; Mac[™] 130-06, 07 and 20; Mac[™] 160S-02 and 03; All Eager Beaver[®] models except 07.

⑥ Used on Mac[™] 110-04, 05, 14 and 15; Mac[™] 120-11 and 17; Mac[™] 130-12 and 13; and Eager Beaver[®] -07.

⑦ See Service Bulletin 1833. When replacing metal pawls with plastic pawls, order these components. The plastic drum is also available with these components by ordering Starter Drum/Pawl Kit, p/n 213261.

⑧ One of two (2) Stop Switch Connectors Installed by the factory. Be sure to identify the connector used on your unit before ordering replacement parts. Note: Item 51, p/n 219389 may be used as replacement for Items 55, 56 and 57.

⑨ Used on 11 level Eager Beaver[®] units.

⑩ Used on 12 level Eager Beaver[®] models and 17 level and 18 level Mac[™] models.

⑪ Used on units equipped with Auto Sharp[™].

⑫ Used on Mac[™] 160 S and Eager Beaver[®] Super 16 models only.

⑬ If the Crankshaft Bearing and Seal have been installed into a Metal Sleeve, order part number 93763 which includes the Sleeve and Item numbers 89 and 90.

Figure 5 CHAIN BRAKE ASSEMBLY

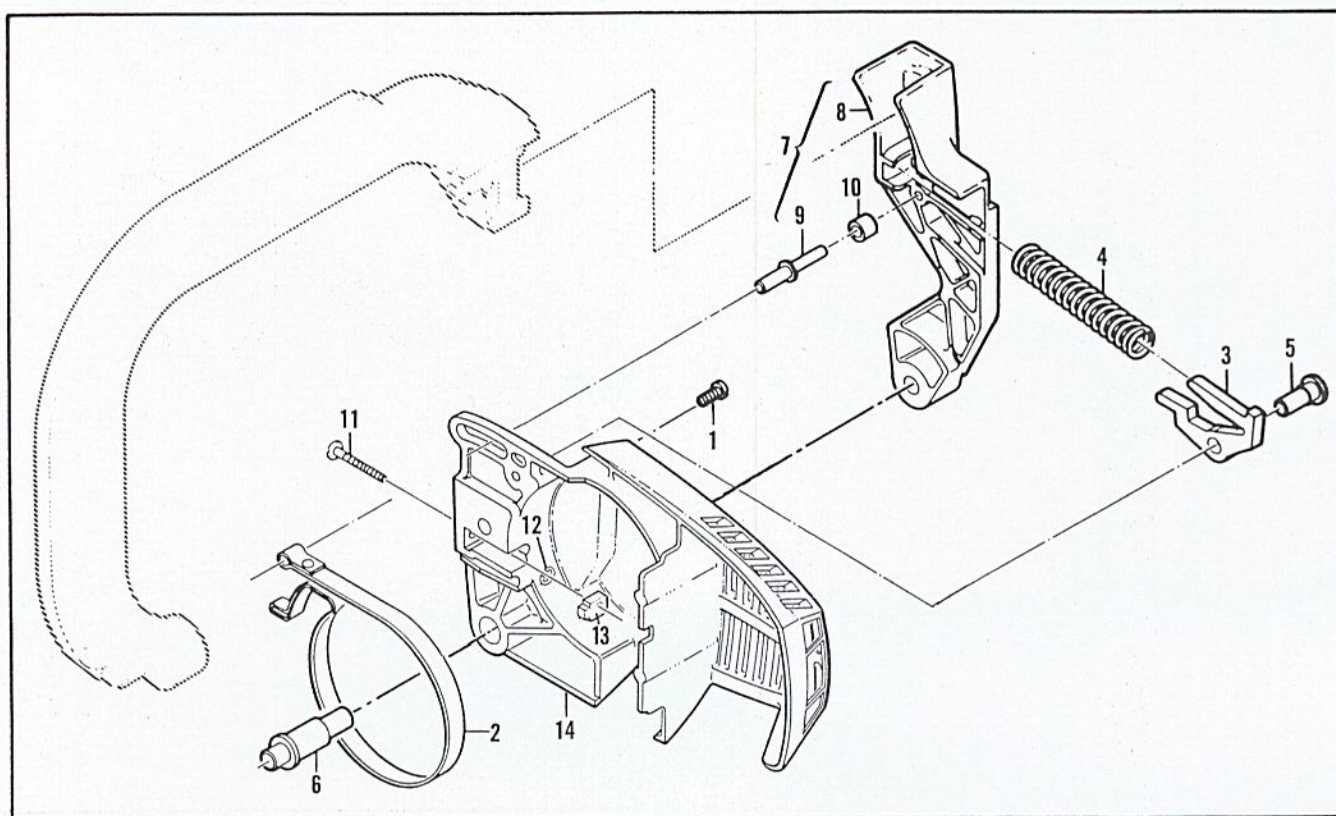

ITEM NO.	PART NUMBER	DESCRIPTION	UNITS PER ASY.
	216551 ①	Chain Brake Assembly	1
	216417 ②	Chain Brake Assembly	1
1	111047	. Screw-Pan Hd 8-32 x .625	1
2	94709	. Band-Brake	1
3	215758	. Kit-Latch	1
4 Spring-Compression	1
5	93602	. Pivot-Latch	1
6	216549	. Pivot-Lever	1
7	216417	. Lever Assembly-Actuating	1

ITEM NO.	PART NUMBER	DESCRIPTION	UNITS PER ASY.
8	92867	. . Lever	1
9	213907	. . Pin-Roller	1
10	214368	. . Bearing-Roller	1
11	90658	. Screw-Adjusting	1
12	110907	. Ring-Retaining	1
13	84929	. Nut-Bar Adjusting	1
14	216553 ①	. Housing-Brake	1
	216414 ②	. Housing-Brake	1

① Used on Mac 110-A, N and O; Mac 120-P and Q; and Mac 130-F and L.

② Used on all Eager Beaver and Mac 110-C, D, E and H; Mac 120-B and K; and Mac 130-G, M and T.

SPECIFICATIONS

Displacement	2.0 cu. in.
Bore & Stroke.	1.430 x 1.201 in. (36.5 x 30.5mm)
Bearings-Main & Con Rod.	Needle
Intake System.	3rd Port, Piston Timed
Fuel Capacity.	10.8 oz. (320cc)
Oil Capacity	3.2 oz. (95cc)
Clutch Engaging Speed. .	3800 to 4200 r.p.m.
Idle Speed	2700 to 2900 r.p.m.
Ignition	Solid State Electronic

Carburetor	Diaphragm Type, 2 Needle
Fuel Type.	Regular Grade Leaded or unleaded
Fuel/Oil Mixture	40:1 Using McCulloch Oil
Filter System-Fuel	Felt
Filter System-Air.	Flocked Screen
Lamination Gap008" to .012" (.203 to .304mm)
Piston Rings (2)	Cast Iron Compression
Weight (Power Unit Only)	10.1 lbs (4.6 kg)

ACCESSORIES

ITEM NO.	PART NO.	DESCRIPTION
1	68915-01	Kit-Piston Pin Installation/ Removal Tool
2	93900	Kit-Cylinder/C'case Pressure Test
3	215432	Gauge-Pressure Test
4	67537	Loctite-10cc Bottle
5	69794	Primer-Locquic 6 oz.
6	110083	R.T.V. Sealant
7	214219	Wrench/Screwdriver
8	216063	Key-Socket 5/32"
9	215824	Carrying Case/Scabbard 12" to 14" Bar
10	214201	Scabbard 10" to 12" Bar
11	214202	Scabbard 14" Bar
12	214195	Bar Sprocket Tip Lube Gun (Plastic/Disposable)
13	214194	Bar Sprocket Tip Lube Gun (Metal/Reusable)