



ILLUSTRATED PARTS LIST

MODEL #CE-2188RS

CUTTERS EDGE®

Cutters Edge, Division of Edge Industries, Inc.

3855 23rd Street
P.O. Box 846
Baker City, OR 97814
U.S./Canada - 1.800.433.3716
International - (+) 1.541.524.9999
Email - info@cuttersedge.com
Web - www.cuttersedge.com

EAST COAST SERVICE CENTER

Eastern Fire Equipment Services

326 Pleasant View Road
New Cumberland, PA 17070
U.S. Phone - 717.412.7746
Email - office@efesinc.com

JUNE 2013

Q:\ Good Documents \ Manuals & Products \ CE2188RS IPL



Illustrations and Parts Ordering Numbers For CE-2188-RS MULTI-CUT® Fire Rescue Saw

Chain Brake / Front Handle A1	1
Clutch Cover A2	2
Clutch / Oil Pump B	3
Cover C	4
Cylinder D	5
Crank Shaft / Muffler E F	6
Intake G	7
Fuel Tank H	8
BULLET™ Chain I J	9
Guard Deflector / Guard Depth Gauge K	10
Handle L	11
Crankcase (Diagram) M	12
Crankcase (Parts List) M	13
Rotor N	14
Starter O	15
Accessories P	16
Labels Q	17

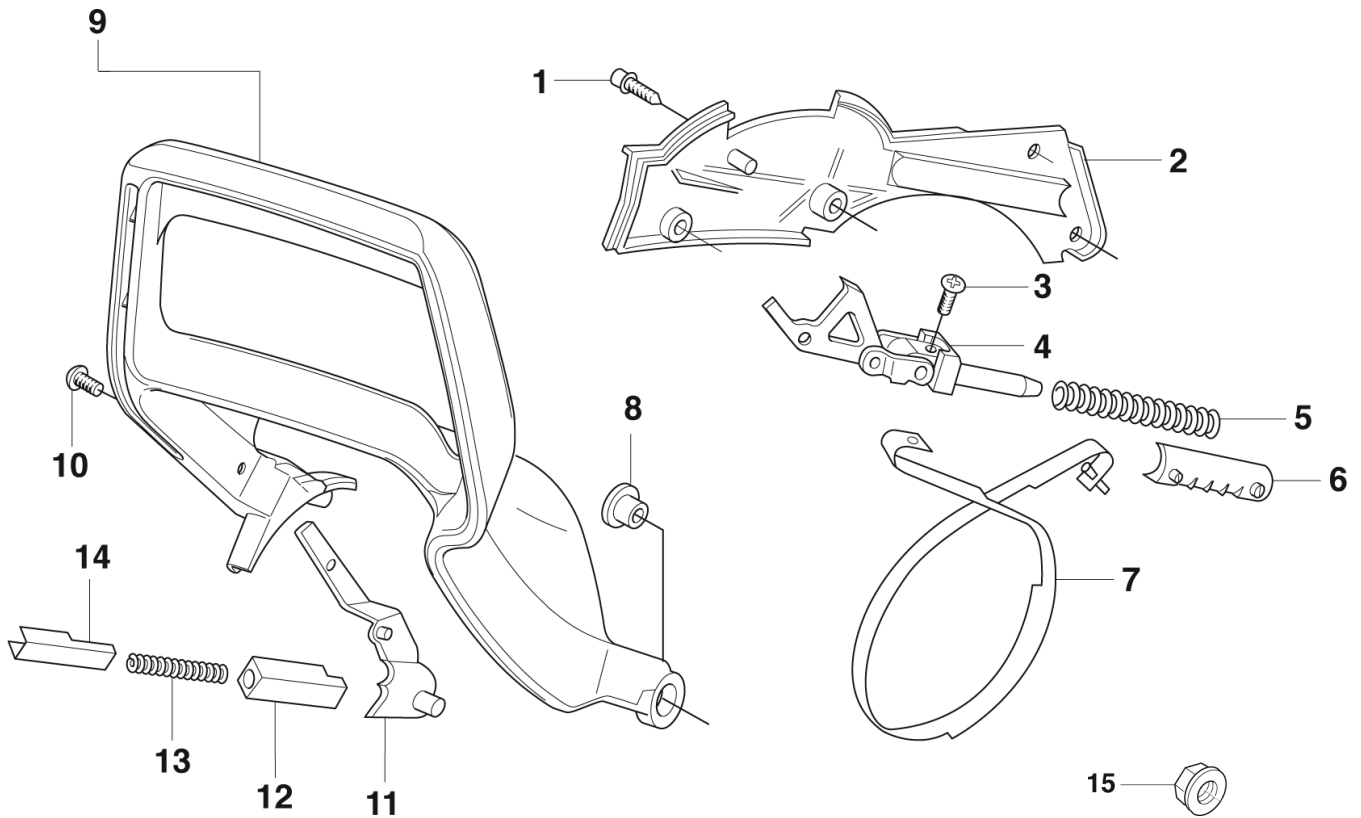

Page A1

Position	Article	Quantity	Description	Kit
1	503 20 07-12	4	Screw, 2100	
2	503 75 11-03	1	Brake Spring Cover	
3	503 21 28-10	1	Screw, All Models	
4	501 87 53-04	1	Knee Joint, 2188	
5	503 70 99-01	1	Spring 2000/2100	
6	503 79 27-01	1	Support 2000/2100	
7	503 75 22-02	1	Brake Band 2000/2100	
8	503 77 52-01	1	Bushing 2000/2100	
9	537 19 57-01	1	Hand Guard	
10	503 20 25-12	1	Screw, Brake Handle, 2100	
11	537 00 87-02	1	Brake Lever, 2100	
12	503 83 81-02	1	Catch, 2100	
13	503 43 65-01	1	Lock Spring, 2100	
14	537 01 67-01	1	Wear Protection	
15	503 22 00-01	2	Bar Nuts, M8, All Models	

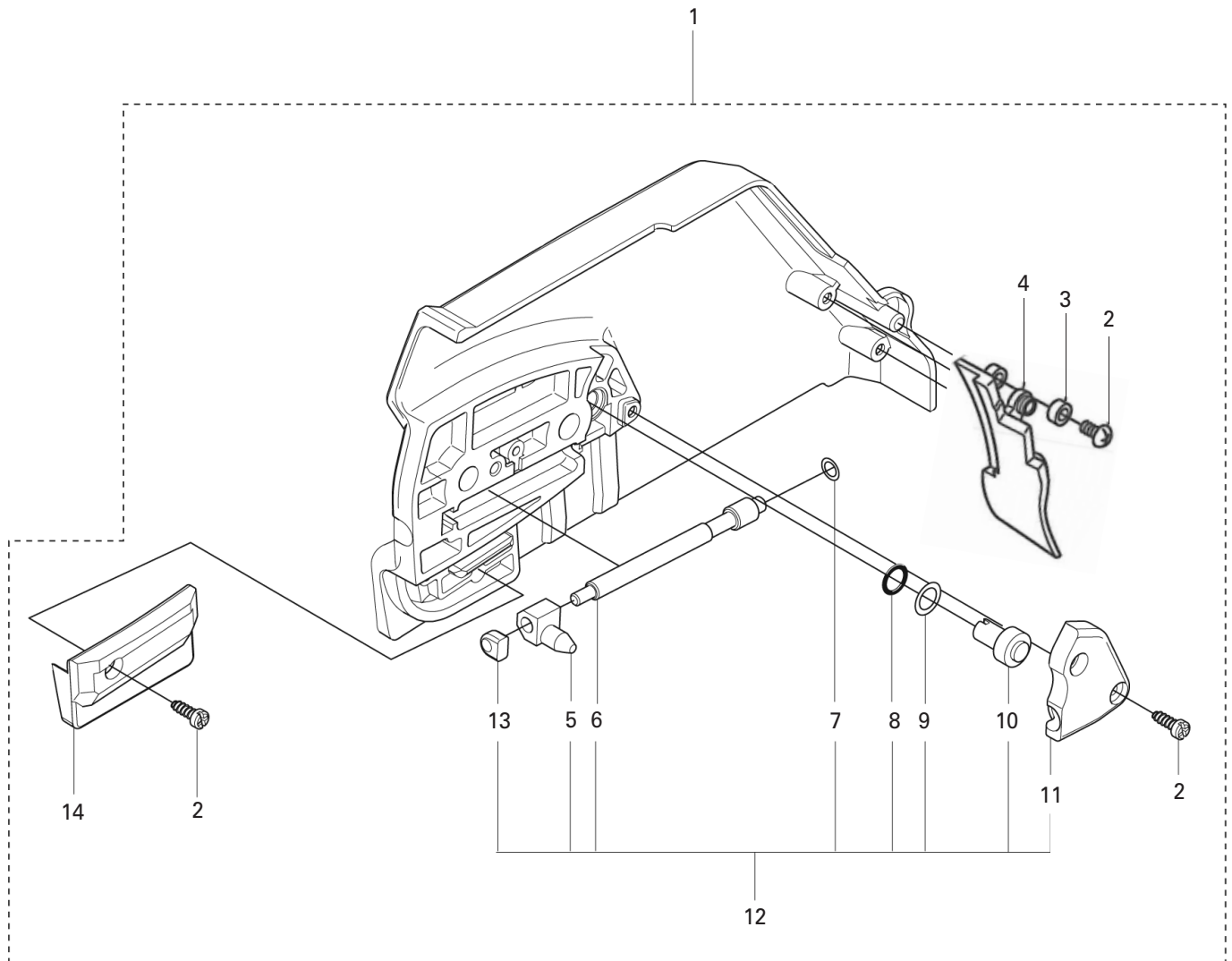

Page A2				
Position	Article	Quantity	Description	Kit
1	537 07 20-02	1	Clutch Cover Assy.	
2	503 21 28-10	3	Screw, Various Models	1
3	503 89 70-01	1	Sleeve Washer, 2188	1
4	503 76 29 02	1	Dust Deflector	1
5	503 99 83-01	1	Sleeve Washer, Prawl	1, 12
6	537 07 95-02	1	Worm Screw, 2188	1, 12
7	503 23 00-66	1	Spacer, 2100	1, 12
8	740 48 07-02	1	O-Ring, 2100	1, 12
9	503 23 00-63	1	Washer, 2100	1, 12
10	537 07 94-02	1	Tensioner Pinion, 2188	1, 12
11	537 01 68-01	1	Tensioner Cover, 2100	1, 12
12	537 04 41-02	1	Tensioner Adjuster, 2100	1, 12
13	537 01 74-01	1	Grommet	1, 12
14	537 19 06-01	1	Chain Guide	1

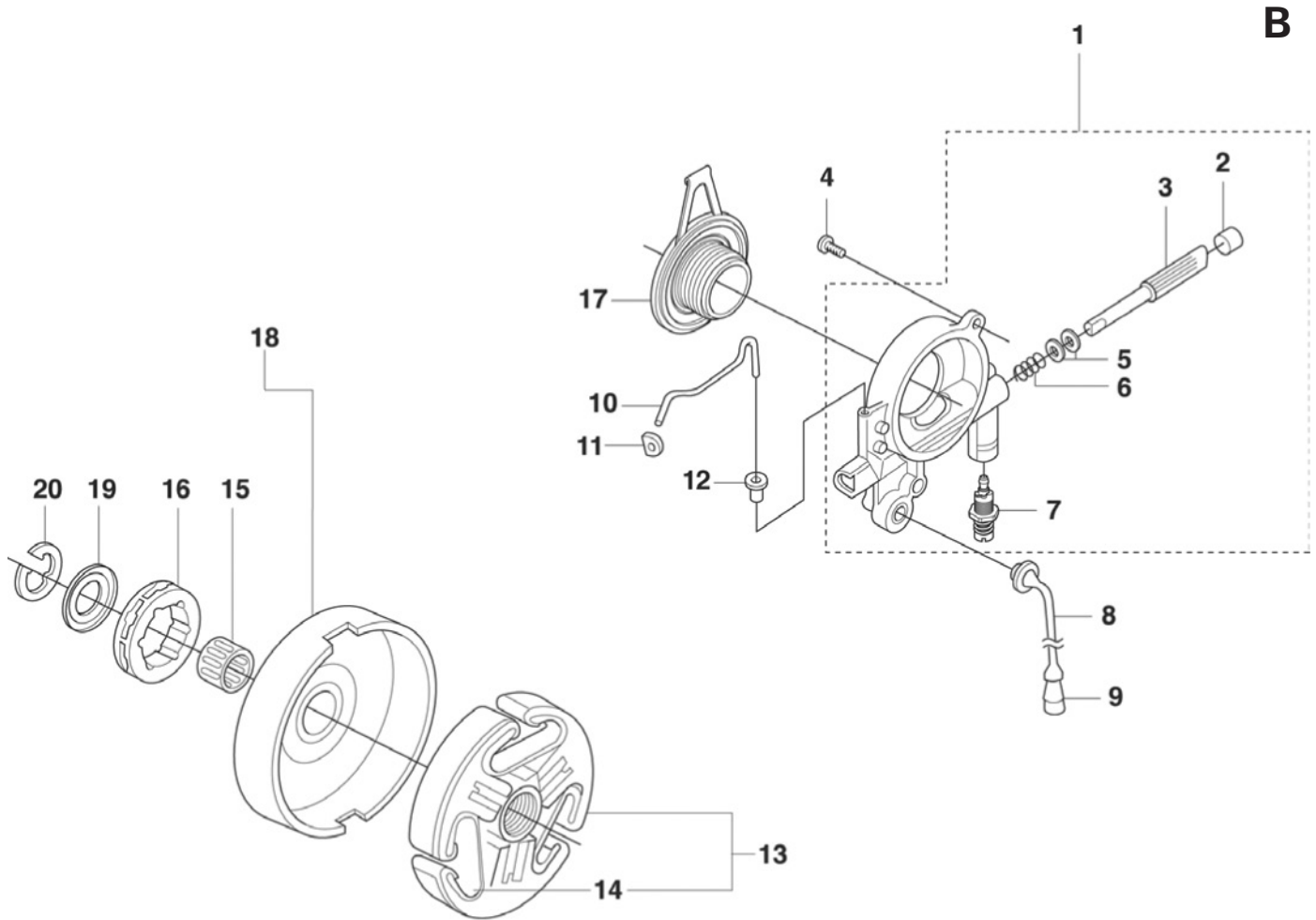

Page B

Position	Article	Quantity	Description	Kit
1	503 52 13-05	1	Oil Pump, 2100	
2	503 62 49-01	1	Plug 2000 / 2100	1
3	537 10 64-01	1	Oil Pump Piston	1
4	725 53 29-56	2	Oil Pump Screw	
5	503 23 00-04	2	Oil Pump Washer	1
6	501 61 58-01	1	Spring	1
7	537 39 60-01	1	Oil Adjuster Screw	1
8	503 42 67-01	1	Oil Hose, 2100	
9	501 54 41-02	1	Oil Pickup Screen, 2100	
10	503 77 43-01	1	Pipe	
11	503 64 47-01	1	Grommet	
12	504 30 00-26	1	Oil Line Grommet	
13	503 97 50-01	1	Clutch	
14	503 97 51-01	3	Clutch Spring	13
15	503 43 20-01	1	Needle Bearing	
16	CE 22270S	1	404 X 7T Rim Sprocket	
17	537 20 78-06	1	Oil Pump Pinion, 86/88	
18	CE102383X	1	Clutch Drum	
19	503 75 24-01	1	Clutch Washer, 2100	
20	503 27 21-01	1	Retaining Clip, 2100	

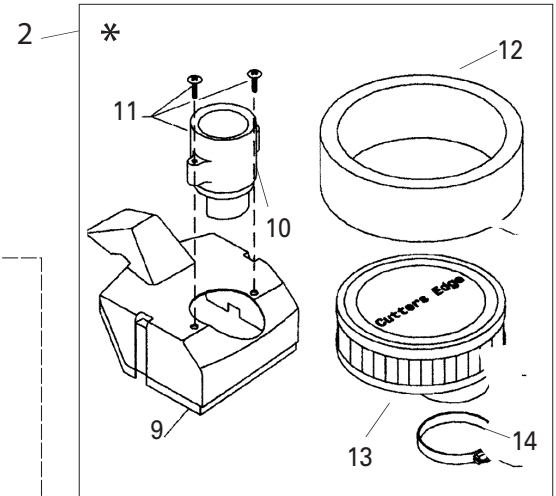
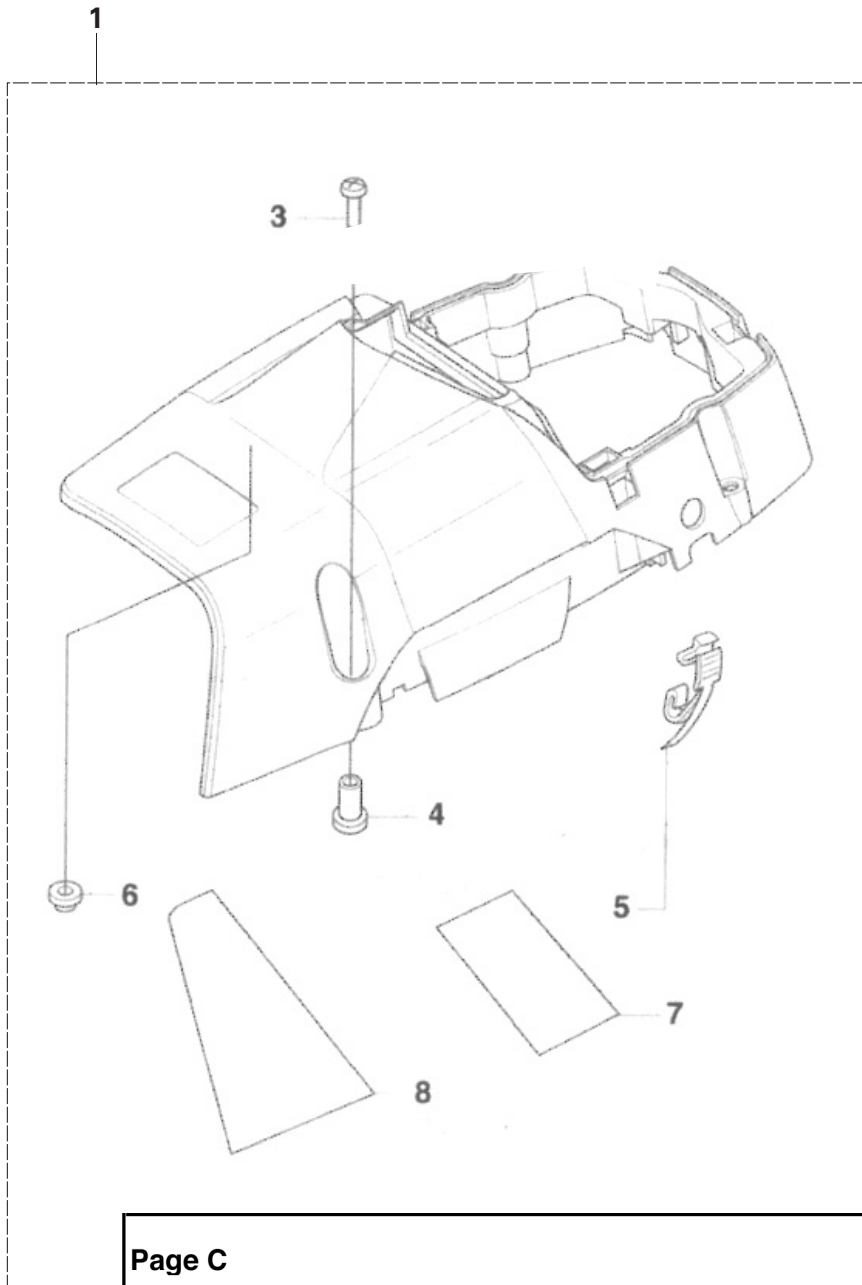

CEFC2186A* Contains:

9	CEMOD86	86/88 Modified Cover	2
10	CEFS86	86/88 Filter Stack	2
11	CE8X12	Filter Stack Screw	2
12	CEPW6571	Pre-Wrap	2
13	CERU2100	Air Filter	2
14	CERUCF2100	Air Filter Hold Clamp	2

Page C

Position	Article	Quantity	Description	Kit
1	537 16 80-01	1	Cylinder Cover	
2	CEFC 2186A*	1	Filter Cover Assy. /86/88	2
3	503 20 44-26	3	Cylinder Cover Screw	1
4	537 13 72-01	3	Sleeve	1
5	503 69 91-02	4	Cover Clip 2000/2100	1
6	537 01 65-01	1	Support	1
7	537 25 35-01	1	Heat Protector	1
8	537 25 34-01	1	Heat Protector	1

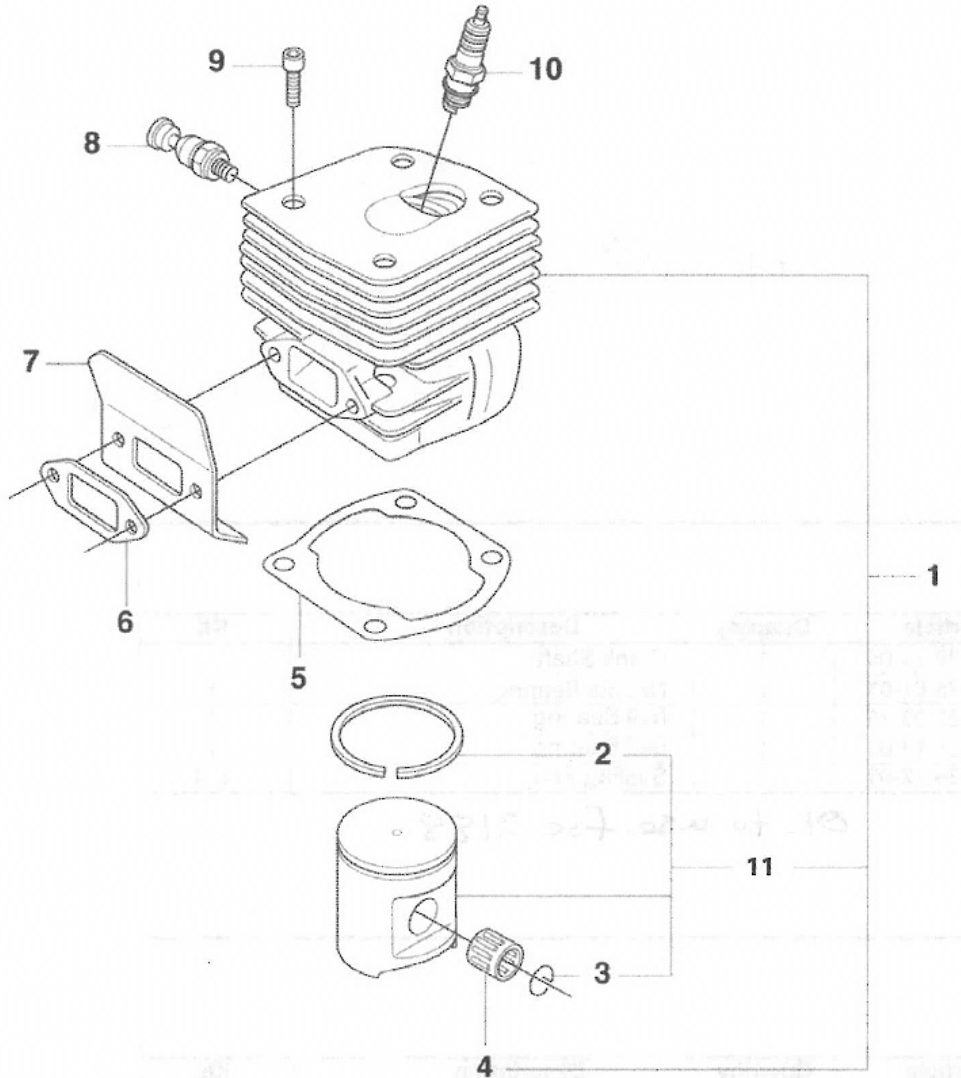

Page D				
Position	Article	Quantity	Description	Kit
1	544 00 65-02	1	Cylinder Assembly, 2188	
2	503 28 90-53	2	Piston Ring	1, 11
3	737 44 13-00	2	Clip , 86/88	1, 11
4	503 25 61-01	1	Needle Bearing	1, 11
5	537 00 57-01	1	Base Gasket	See Pg. J
6	503 77 59-01	1	Muffler Gasket 2000/2100	See Pg. J
7	537 08 62-01	1	Heat Deflector	
8	503 71 53-01	1	Decompression Valve	
9	725 53 33-55	4	Cylinder Bolt	
10	CECJ7Y	1	Spark Plug	
11	537 42 02-02	1	Piston Assembly	1, 11

E

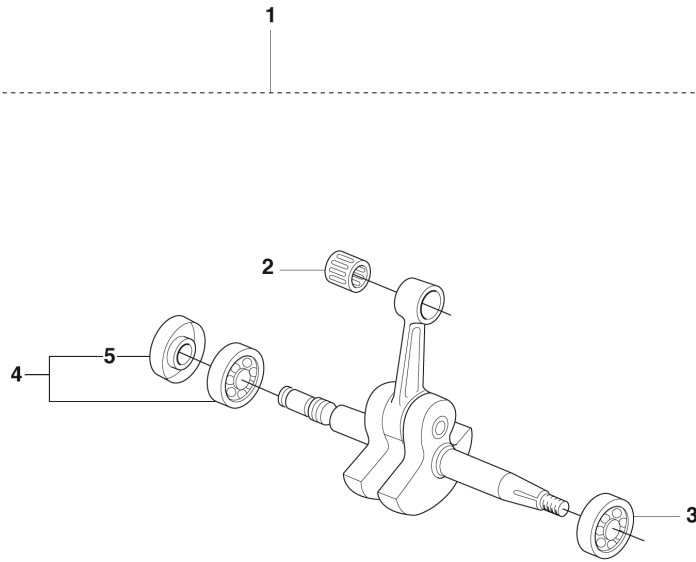

Page E

Position	Article	Quantity	Description	Kit
1	503 99 34-04	1	Crank Shaft	
2	503 25 61-01	1	Needle Bearing	1
3	738 22 03-25	1	Ball Bearing	1
4	503 25 13-01	1	Ball Bearing	1
5	503 26 22-01	1	Sealing Ring	1, 4

F

Page F

Position	Article	Quantity	Description	Kit
1	544 02 91-04	1	Muffler	
2	724 12 87-59	1	Screw, Muffler Screen 2100	1
3	503 76 64-02	1	Muffler Screen 2000/2100	1
4	725 53 70-55	2	Muffler Bolt 2000/2100	
5	503 76 65-03	1	Muffler Bracket	
6	CEGD6571-8	1	Screw 5 X 15	
7	CEGD6571-5	2	Screw 5 X 30	

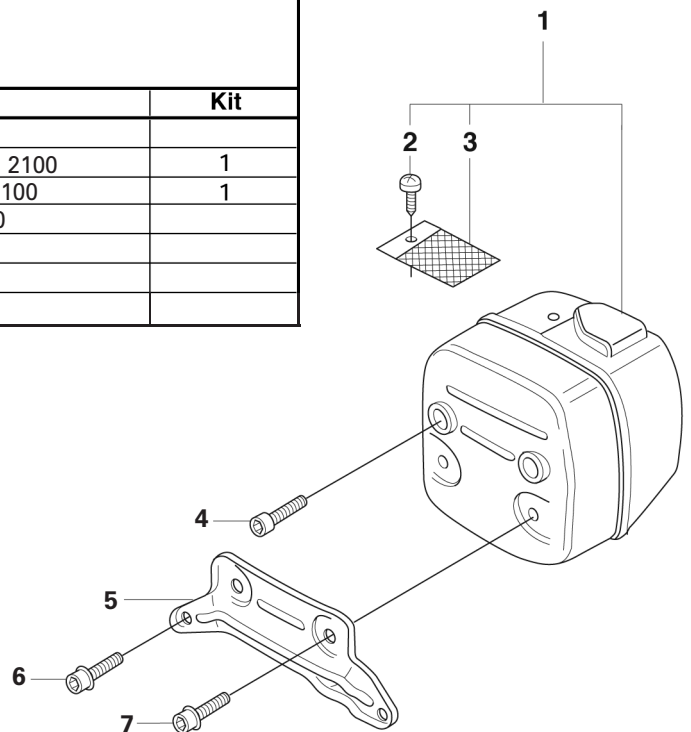

Note: Refer to Guard Deflector on Pg. 10

G

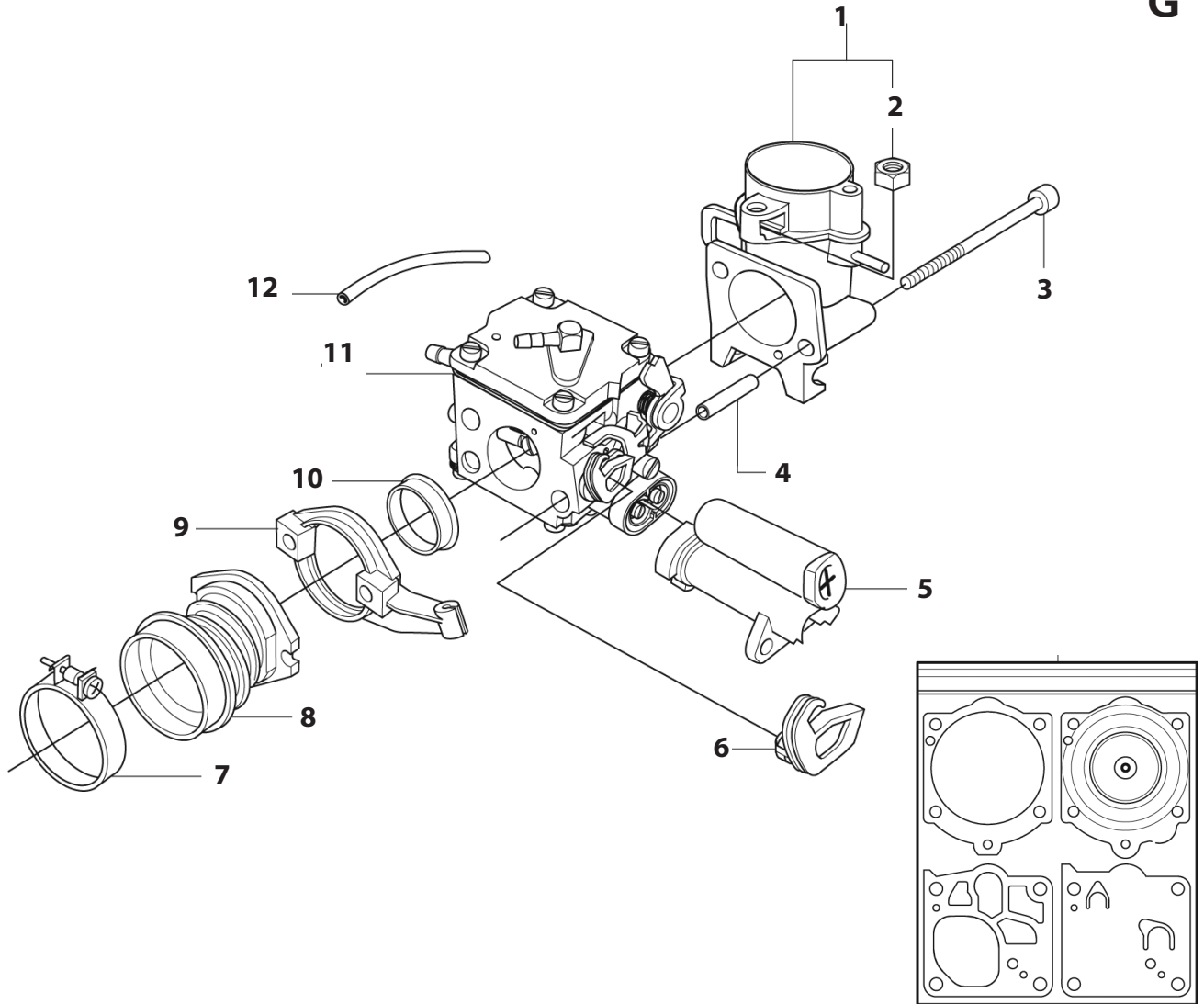

***13 - Choose appropriate kit from parts list**

G				
Position	Article	Quantity	Description	Kit
1	537 00 91-01	1	Filter Holder	
2	731 23 14-01	1	Nut	1
3	725 53 09-55	2	Carburetor Mounting Screw	
4	503 70 11-01	2	Tube 65/71 Carburetor	
5	544 97 51-01	1	Adjustment Guide	
6	503 68 41-01	1	Carb Lever	
7	505 28 33-02	1	Hose Clamp	
8	537 11 14-01	1	Carb Boot	
9	537 00 37-01	1	Flange	
10	503 96 22-01	1	Support Sleeve	
11	501 35 52-01	1	Carburetor	
12	503 40 06-04	1	Pulse Hose	
13*	522 59 18-01	1	Walbro Carb Kit	
13*	RK 32HS	1	Tilotson Carb Kit	

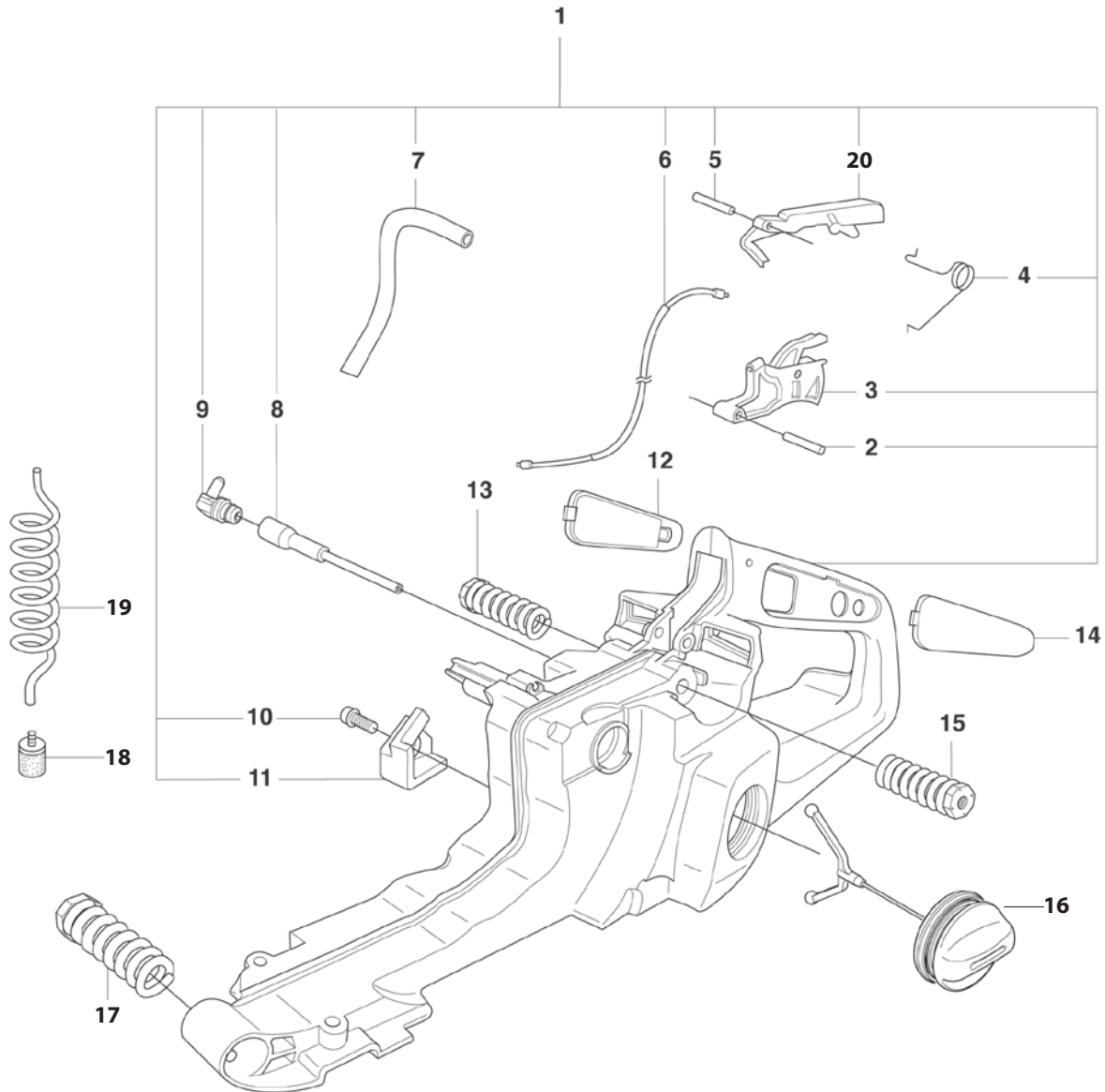

Page H

Position	Article	Quantity	Description	Kit
1	537 00 03-72	1	Fuel Tank	
2	720 12 72-20	1	Pin Handle ,2100	1
3	503 82 98-02	1	Throttle Trigger ,2100	1
4	503 73 64-01	1	Spring Handle ,2100	1
5	720 12 40-20	1	Pin Handle ,2100	1
6	503 71 76-01	1	Throttle Wire, 2100	1
7	544 32 49-06	1	Fuel Tank Vent Hose	1
8	537 09 22-01	1	White Fuel Tank Vent Insert	1
9	537 09 93-01	1	Fuel Tank Vent Elbow	1
10	503 21 88-74	1	Cover Screw	1
11	537 00 88-02	1	Cover	1
12	537 03 34-02	1	Handle Insert	
13	537 01 79-01	1	Insulator	
14	537 03 34-02	1	Handle Insert	
15	537 01 79-01	1	Insulator	
16	537 21 52-01	1	Fuel / Oil Cap 2100	
17	537 01 75-01	1	Insulator	
18	503 44 32-01	1	Fuel Filter	
19	544 32 50-02	1	Fuel Line 350	
20	503 55 66-02	1	Throttle Lock 2100	1



CE BUL 76A
24" Bullet Chain Loop
76 Drive Links
(For 2186 and 2188 Saws Only)



CE BUL66A
20" Bullet Chain Loop
66 Drive Links

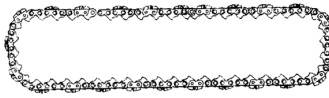

CE BUL56A
16" Bullet Chain Loop
56 Drive Links



CE BUL48A
12" Bullet Chain Loop
48 Drive Links

CE BUL 76A	24" Bullet Chain Loop - 76 Drive Links*
CE BUL66A	20" Bullet Chain Loop-66 Drive Links
CE BUL56A	16" Bullet Chain Loop-56 Drive Links
CE BUL48A	12" Bullet Chain Loop-48 Drive Links
CE BUL-L*	Bullet Cutter-Left Side
CE BUL-R*	Bullet Cutter-Right Side
CE PSBUL*	Bullet Cutter Preset
CE DLBUL	Bullet Cutter Drive Link
CE TSBUL	Bullet Cutter Tie Strap
CERKBULLA**	Bullet Repair Kit-Left Side
CERKBULRA**	Bullet Repair Kit-Right Side

* For 2186 and 2188 Saws Only

**CERKBULLA

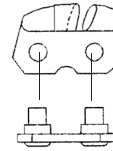

**CERKBULRA

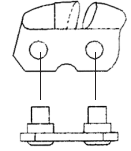

Top View
Chain Assembly

Left Side



Right Side

CE PSBUL*
Preset

Top View

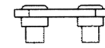

Side View



CE TSBUL
Tie Strap

Top View

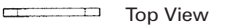

Side View



Left Cutter



Right Cutter

Top View



Drive Link

Top View

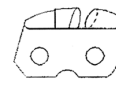

CE BUL-L*



CE BUL-R*



Side View

CE DLBUL

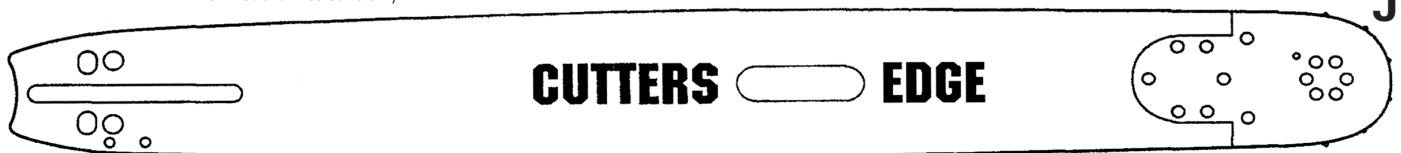

CUTTERS EDGE

CE 2463ST
(For 2186
and 2188
Saws Only)

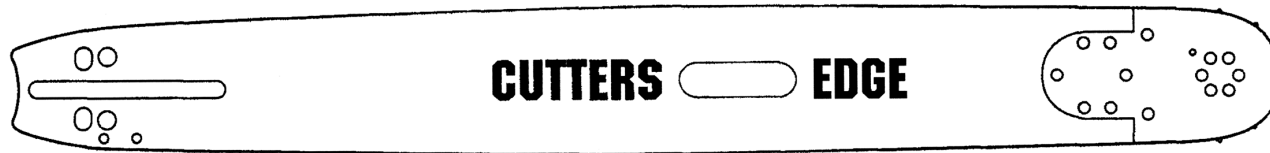

CUTTERS EDGE

CE 2063ST



CUTTERS EDGE

CE 1663ST



CE 1263ST

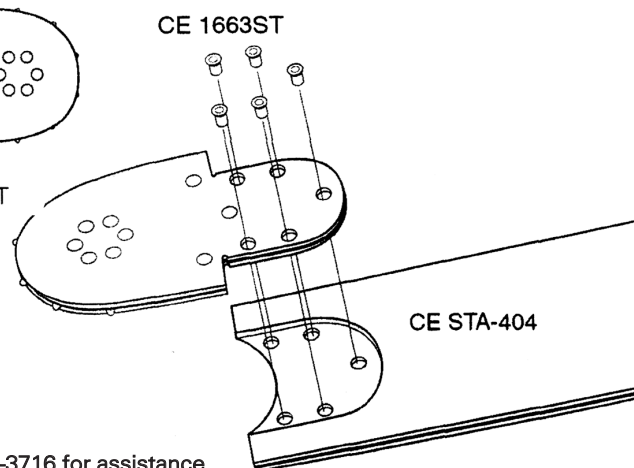

CE STA-404

CE 2463ST	24" High Alloy Guide Bar
CE 2063ST	20" High Alloy Guide Bar
CE 1663ST	16" High Alloy Guide Bar
CE 1263ST	12" High Alloy Guide Bar
CE STA-404	Replacement Sprocket Nose Kit

Note: Different bar styles exist, please call CUTTERS EDGE at 800-433-3716 for assistance.

D10 (24" Saw)

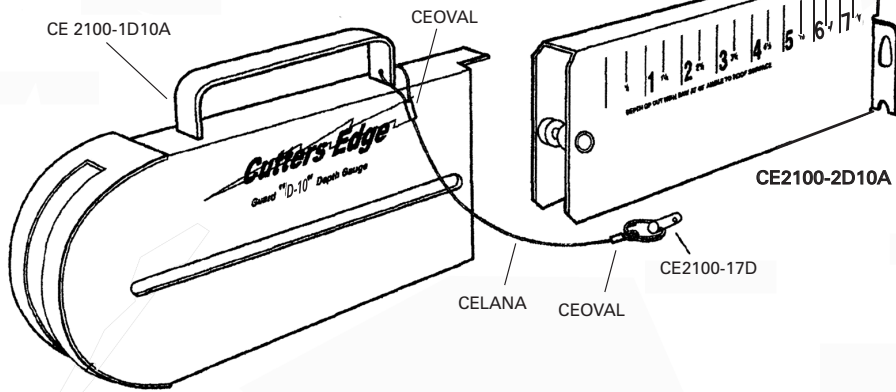

All parts above with (*) can be ordered separately or come as a complete assembly (**)

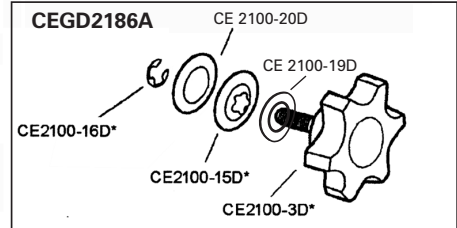
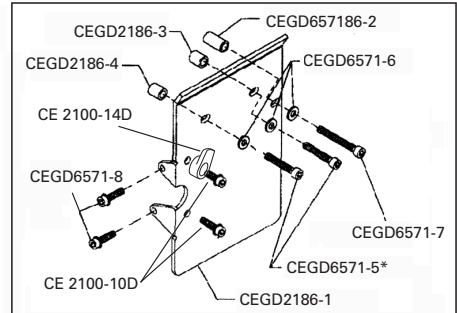

**CE 2100-18DA

D8 (20" Saw)

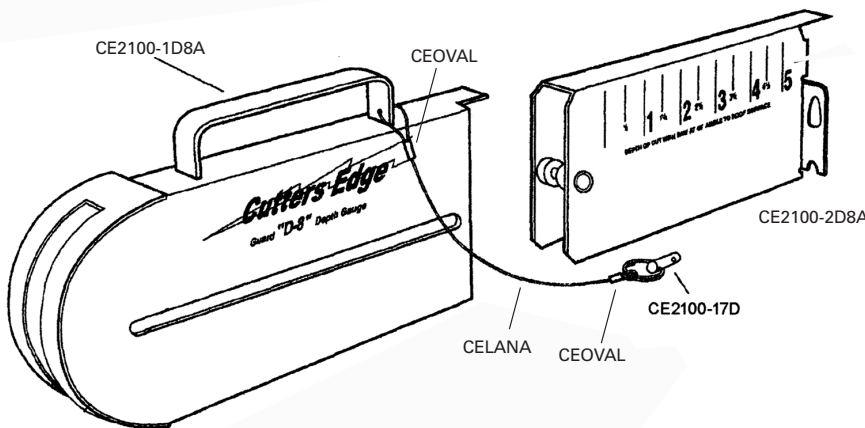

All parts above with (*) can be ordered separately or come as a complete assembly (**)

D6 (16" Saw)

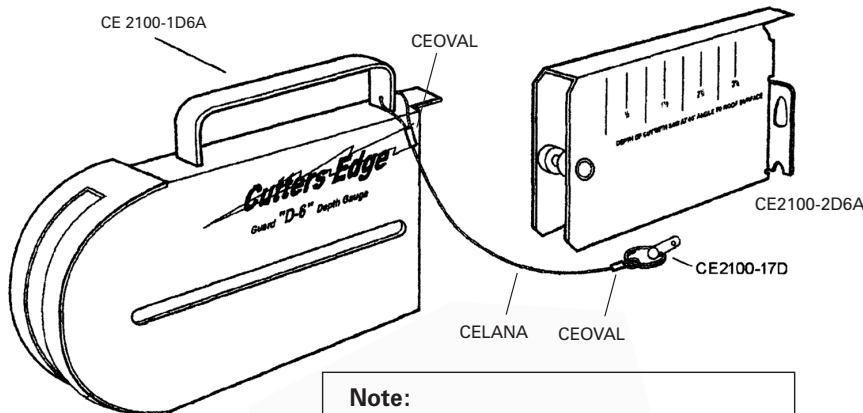

Note:

CE2100-1D10 and CE2100-2D10 for 24" Saw
 CE2100-1D8 and CE2100-2D8 for 20" Saw
 CE2100-1D6 and CE2100-2D6 for 16" Saw

H	Description
CEGD2186A	Guard Deflector Tool-less
CE2100-1D10A	D10 Outer Section
CE2100-1D8A	D8 Outer Section
CE2100-1D6A	D6 Outer Section
CE2100-2D10A	D10 Inner Section
CE2100-2D8A	D8 Inner Section
CE2100-2D6A	D6 Inner Section
CE2100-10D	Allen Screw
CE2100-14D	Tool-less Locking Key
CE2100-15D*	Dome Washer
CE2100-16D*	e-Clip
CE2100-17D	Quick Release Pin
CE2100-18DA**	Knob (Complete)
CE2100-19D	Wave Washer
CE2100-20D	Rubber Washer
CEGD2186-1	Guard Deflector Plate
CEGD657186-2	.685" Stand-Off
CEGD2186-3	.425" Stand-Off
CEGD2186-4	.253" Stand-Off
CEGD6571-5	5x30 Allen Screw
CEGD6571-6	Guard Deflector Washer
CEGD6571-7	5x40 Allen Screw
CEGD6571-8	5x16 Allen Screw
CELANA	Lanyard Complete
CEOVAL	Oval Sleeve

Note:

Replacement decals can be replaced on Page 17 (Q)

All parts above with (*) can be ordered separately or come as a complete assembly (**)

L

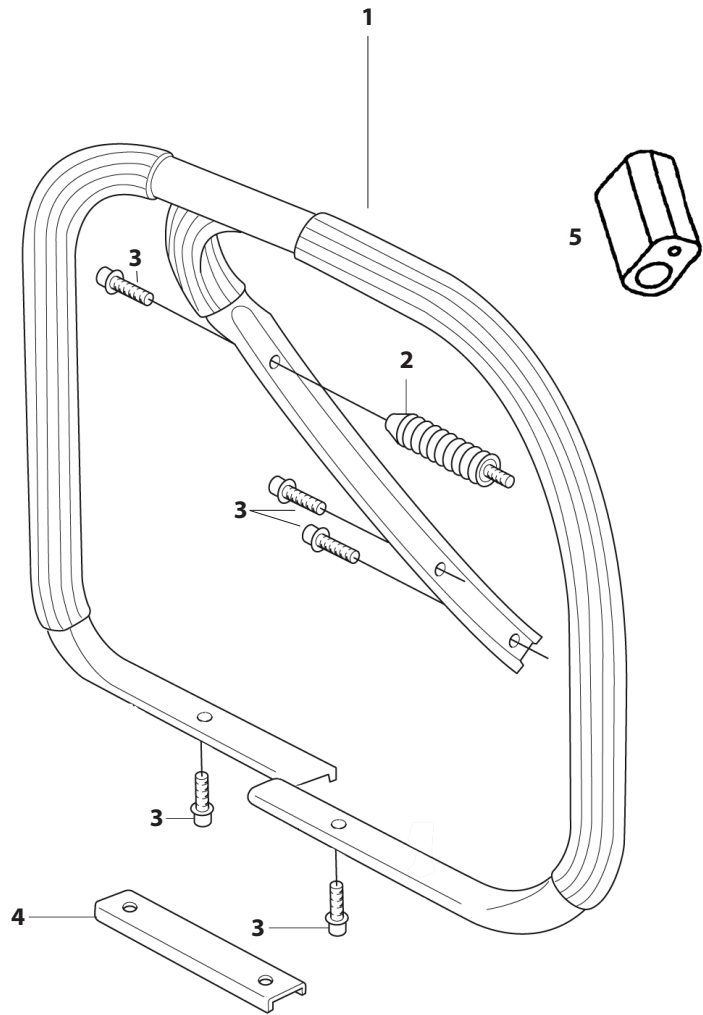

L				
Position	Article	Quantity	Description	Kit
1	537 16 79-71	1	Full Wrap Handle, 2188	
2	503 52 87-02	1	Vibration Absorber	
3	503 21 88-20	5	Screw, 2188	
4	537 03 73-01	1	Reinforcing Handle Plate	
5	CE292TH	1	Scrench Tool Holder	

M

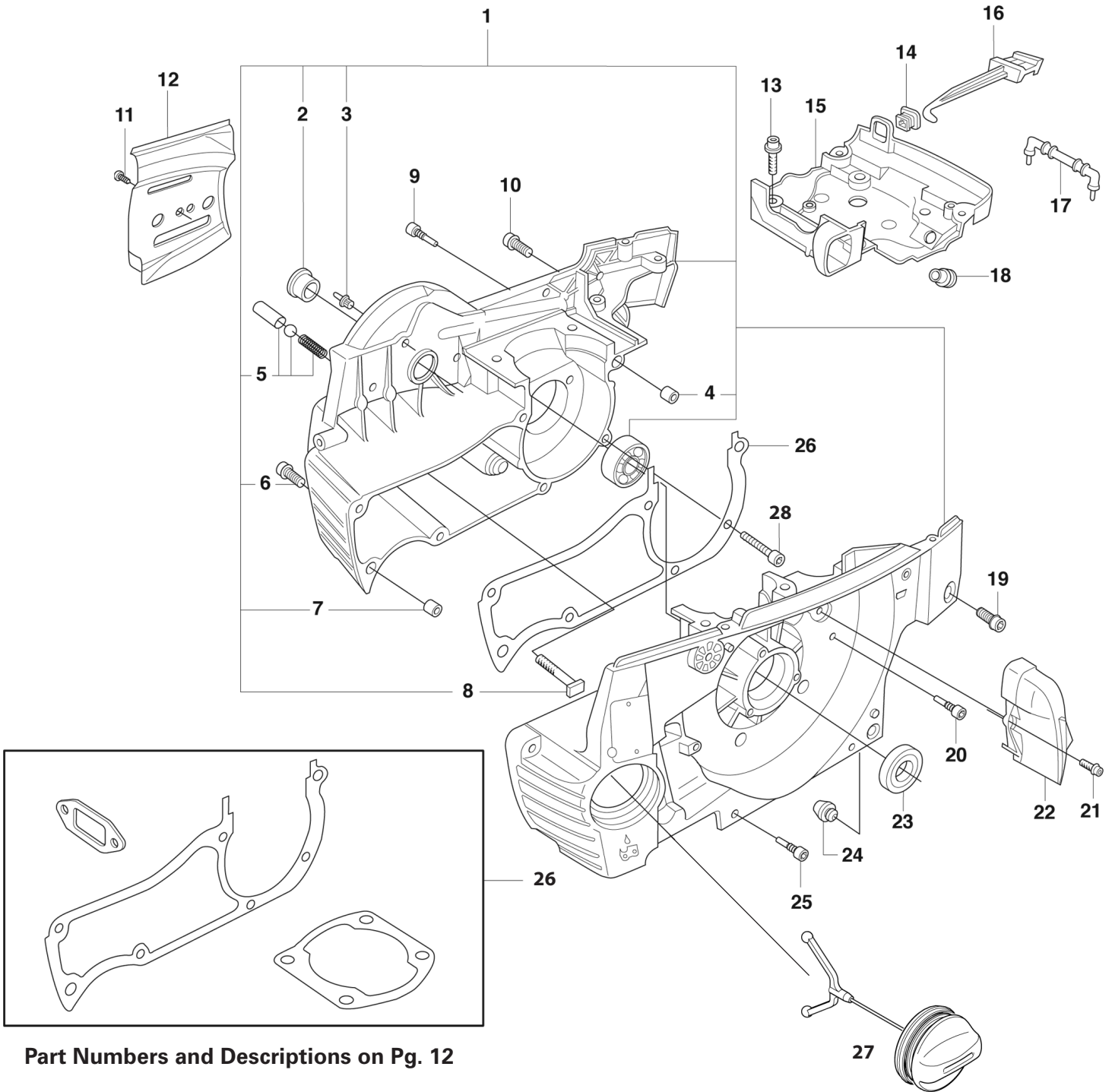

M				
Position	Article	Quantity	Description	Kit
1	503 99 11-06	1	Crankcase Assembly	
2	503 96 70-01	1	Bushing	1
3	503 75 18-01	1	Pin	1
4	501 27 08-01	1	Sleeve 2000/2100	1
5	537 04 03-01	1	Valve 2000/2100	1
6	503 21 88-74	1	Crankcase Screw	
7	501 27 08-01	1	Sleeve 2000/2100	1
8	537 05 13-01	2	Bar Stud	1
9	503 74 93-01	1	Screw	
10	503 21 88-74	1	Screw	
11	503 21 28-10	1	Screw, Various Models	
12	537 04 66-01	1	Bar Plate	
13	503 20 07-12	4	Screw, 2100	
14	503 73 44-01	1	Grommet, Choke 2000/2100	
15	537 00 14-04	1	Carburetor Base	
16	537 00 12-01	1	Choke Control	
17	503 67 86-01	1	Spacer	
18	537 09 54-01	1	Cable Guide Grommet	
19	503 21 88-74	1	Crankcase Screw	
20	503 74 93-01	1	Screw	
21	503 20 07-12	1	Screw, 2100	
22	537 00 79-01	1	Air Conductor	
23	503 26 02-05	1	Crank Shaft Seal	
24	503 84 61-01	2	Buffer 2000/2100	
25	503 74 93-01	1	Screw	
26	537 03 39-01	1	Set of Gaskets (Muffler, Crankcase, Base)	
27	537 21 52-01	1	Fuel/Oil Cap 2100, Black	
28	503 20 16-35	6	Screw	

N

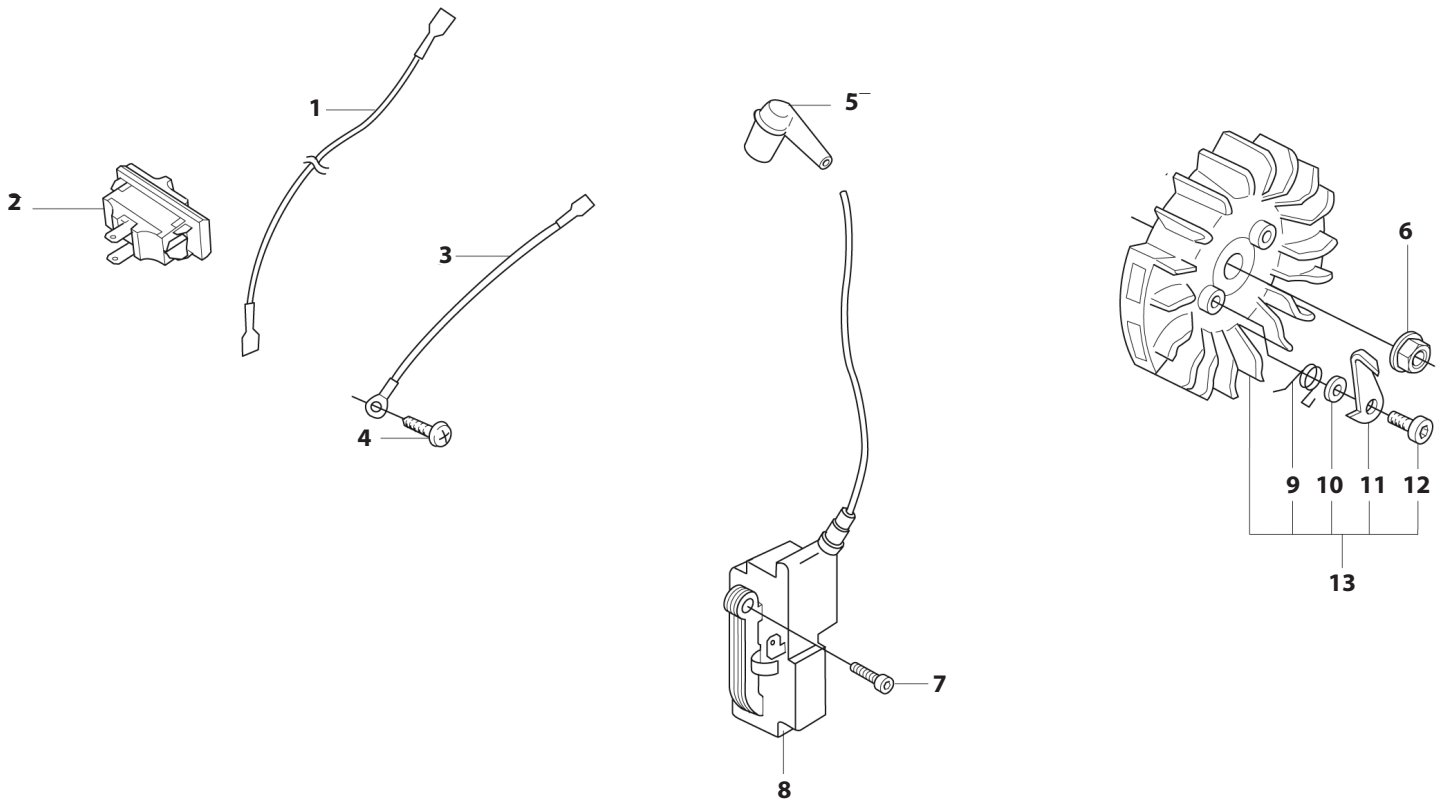

N				
Position	Article	Quantity	Description	Kit
1	503 62 61-02	1	Switch Wire	
2	537 41 90 01	1	Switch	
3	503 89 76-01	1	Shorting Lead	
4	503 21 28-10	1	Screw, Various Models	
5	501 48 54-02A	1	Spark Plug Clip and Boot, All Models	
6	503 22 04-01	1	Flywheel Nut	
7	503 20 02-20	2	Screw	
8	510 11 49-01	1	Ignition Module	
9	501 67 35-01	2	Flywheel Spring, All Models	13
10	503 23 00-42	2	Spacer	13
11	537 01 55-01	2	Starter Pawl	13
12	501 81 99-01	1	Pawl Screw, All Models	13
13	537 05 16-05	1	Flywheel, 65/71/86	

O

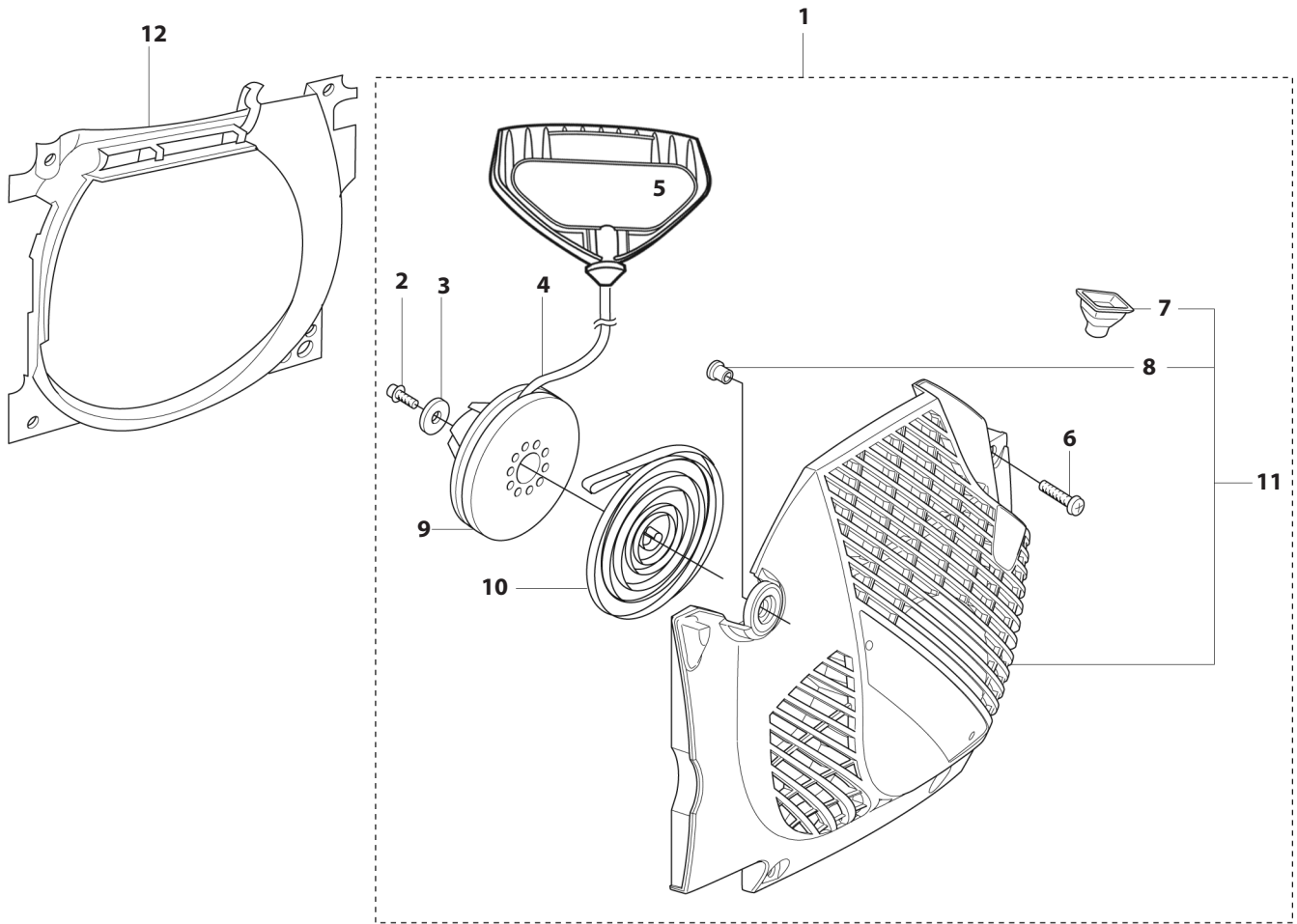

O				
Position	Article	Quantity	Description	Kit
1	537 16 83-71	1	Starter Assembly	
2	503 21 52-02	1	Screw, Starter	1
3	503 23 43-02	1	Washer, Starter - All Models	1
4	503 43 29-02	1	Starter Rope	1
5	CE590574A	1	D-Handle	1
6	503 20 34-19	4	Screw, Starter Cover	1,11
7	501 63 06-01	1	Starter Rope Guide	1,11
8	537 08 67-01	1	Bushing	1,11
9	503 85 96-01	1	Starter Pulley	1
10	503 78 72-01	1	Spring, Starter	1
11	537 16 84-71	1	Starter Housing	1
12	537 00 13-01	1	Air Conductor	

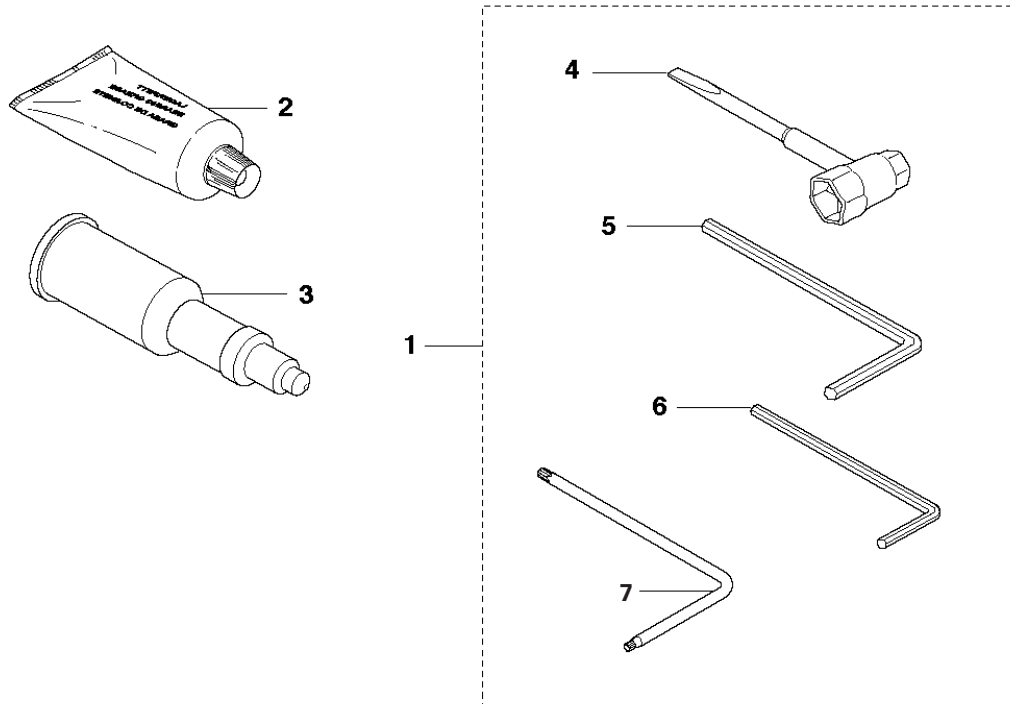

Ref	Part No	Description	Remark	QTY KIT
1	501 75 47-01	TOOL KIT		1
2	503 62 12-01	GREASE		1
3	501 91 14-01	GREASE GUN		1
4	503 13 96-01	COMBINATION WRENCH		1 1
5	503 55 86-02	SPANNER	NV5	1 1
6	503 55 86-01	SPANNER	NV4	1 1
7	575 88 07-01	WRENCH	TORX T27/T20	1 1



Q

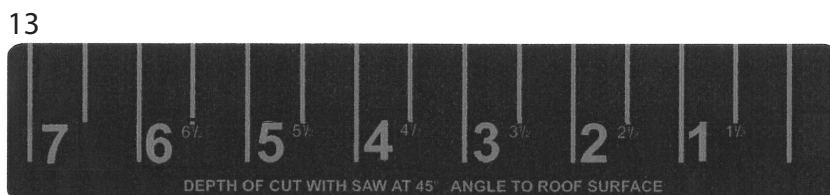
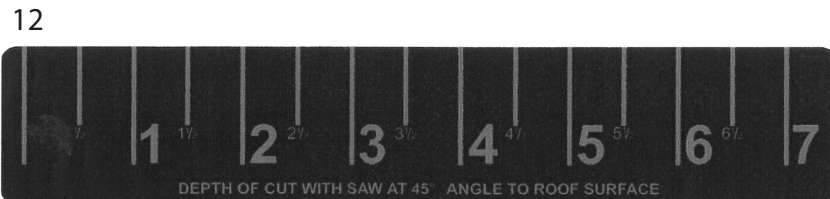
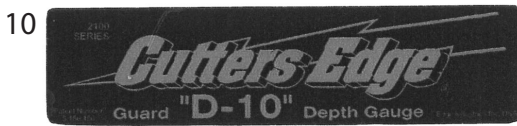
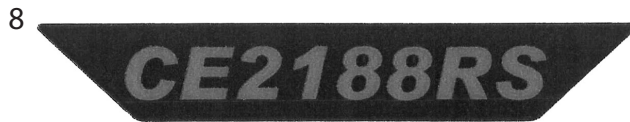
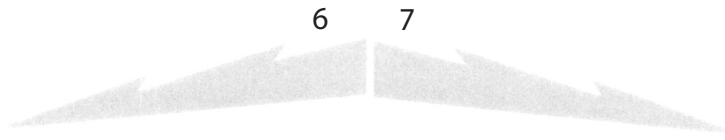

Q			
Pos.	Article	Qty	Description
1	CELTCM2REFL	1	Address Label
2	CELTREDREF	1	CE Text
3	CELFW	1	CE Text Reflective
4	CELWHREF	1	CE Logo Reflective
5	CELSTOP	1	Stop Label
6	CELBOLTL	1	Light. Bolt Left
7	CELBOLTR	1	Light. Bolt Right
8	CEL2188L	1	CE Logo Left
9	CEL2188R	1	CE Logo Right
10	CELD10L2100	1	Logo D10 Left
11	CELD10R2100	1	Logo D10 Right
12	CELD10SCL2100	1	D10 Scale Left
13	CELD10SCR2100	1	D10 Scale Right



CUTTERS EDGE®

P.O. Box 846 • 3855 23rd Street • Baker City, Oregon 97814
TOLL FREE: 800.433.3716 • Telephone: 541.524.9999 • Fax: 541.524.9996 • Email info@cuttersedge.com

East Coast Service Center

Eastern Fire Equipment Services • 326 Pleasant View Rd. • New Cumberland, PA 17070
Tel: 717.412.7746 • Email: office@efesinc.com

www.cuttersedge.com